

---

# **IC Bus™ BE / CE Models**

## **Operation and Maintenance Manual**

**IC Bus, LLC**

2701 Navistar Drive, Lisle, IL 60532 USA

---

## IMPORTANT

The information, specifications, and illustrations contained in this manual are based on data that was current at the time of publication. IC Bus, LLC reserves the right to make changes and/or improvements at any time without notification, liability, or without applying those changes or improvements to vehicles previously manufactured and/or sold.

### NOTICE

Be advised that this motor vehicle may be equipped with computer / recording devices. Their function is to allow an authorized individual to download data or information relating to the operation or performance of this vehicle.

The stored data or information may be neither downloaded nor retrieved except by the vehicle's registered owner, or, in the alternative, by another individual or entity authorized by the registered owner (e.g., IC Bus Dealer) who may need this data or information to properly service or diagnose this vehicle for repair or following an accident.

Any access to this information without the owner's consent may be in violation of law and may subject that person or entity to criminal penalties.

### CALIFORNIA

#### Proposition 65 Warning

Diesel engine exhaust and some of its constituents are known to the State of California to cause cancer, birth defects, and other reproductive harm.

Battery posts, terminals and related accessories contain lead and lead compounds, chemicals known to the State of California to cause cancer and reproductive harm.

Wash hands after handling.

---

---

## IMPORTANT

It is important that the applicable vehicle identification number (VIN), engine serial number and or component feature codes are recorded. These numbers are required to obtain pertinent information for this vehicle or engine.

### VEHICLE IDENTIFICATION NUMBER (VIN)

--

### CUSTOMER ASSISTANCE CENTER

1-800-44-TRUCK (1-800-448-7825)

### ENGINE

Feature Code:	Serial Number:

### Navistar, Inc.

2701 Navistar Drive  
Lisle, IL 60532 USA  
www.navistar.com

### FRONT AXLE

Feature Code:	Serial Number:

### IC Bus, LLC

2701 Navistar Drive  
Lisle, IL 60532 USA  
www.navistar.com

### REAR AXLE

Feature Code:	Serial Number:

### TRANSMISSION

Feature Code:	Serial Number:

### TRANSFER CASE

Feature Code:	Serial Number:



---

### Summary of Changes

Section	Description
All	Updated Cautions and Warnings
Section 9 - Operation	Added Air Disc Brake Content

---

---

**Section 1 – Introduction**

Preface.....1  
 Cautions / Warnings / Notes.....1  
 Vehicle Identification.....1  
 Assistance Guide.....2  
 Component Code Numbers.....2  
 Line Set Ticket.....2  
 Vehicle Storage Instructions.....2  
     Storage Duration – One Month or Less.....3  
     Storage Duration–Over One Month .....3  
     Diesel Exhaust Fluid (DEF) Storage.....4  
 Reporting Safety Defects.....4  
     U.S. Registered Vehicles.....4  
     Canadian Registered Vehicles.....5  
 Safety Recalls and Authorized Field Changes.....5  
 Emission Control Systems.....5  
     HD-OBD Foreword.....5  
     Supplemental Federal Emission Control System  
     Warranty.....5

**Section 2 – Vehicle Inspection Guide**

Introduction.....9  
 Inspection Check Lists.....16  
     Exterior Checks.....16  
     Front Suspension.....18  
     Brakes.....18  
     Underhood and Fluid Checks.....19  
     Interior Visual and Operational Checks.....21  
     Integrated Air Conditioning System (IC Air).....23  
     Auxiliary Fuel-Fired Heater System.....24  
     Emergency Exits and Equipment.....24

**Section 3 – Instrumentation**

Instrument Panel Gauge Cluster.....27  
     Warning Indicators.....30  
     Instrument Panel Gauge Cluster.....33  
     Direct Drive Warning Indicators.....34  
     Integral Digital Display.....35  
     Integral Digital Display Detailed Information.....37  
     Outside Temperature and Compass Displays (Optional)...49  
     Outside Temperature Reading.....50  
     Optional Instrument Panel Gauge Cluster Compass  
     Calibration Procedure.....51  
     Compass Declination Zone Set Procedure.....51  
     Compass Directional Calibration Procedure.....54  
     User Switches.....56  
     Instrument Panel Gauge Audible Alarms.....57

**Section 4 – Driver Controls**

Windshield Wiper / Washer System.....59  
     Wiper Blade Speed.....59  
     Windshield Wiper Speed Control.....59  
     Windshield Washer.....59  
 Turn Signal.....60  
 Steering Wheel and Column.....60  
     Steering Wheel Controls (BE Optional and CE  
     Standard).....60  
     Steering Wheel Controls (BE Standard and CE  
     Optional).....61  
     Horn.....61  
     Adjustable Tilt Steering Column.....61  
 Left Console Switch Panel.....62  
     Rocker Switches and Their Functions.....62

## Table of Contents

---

Power Outlet.....	66
Transmission, Parking Brake, and Ignition Switch Panel.....	66
Right Console Switch Panel.....	68
Rocker Switches and Their Functions.....	68
Cruise Control.....	71
Operation.....	71
Mirror Adjustment.....	71

### Section 5 – Lights

Headlight Switch and Panel Lighting Control.....	75
Headlight Switch.....	75
Automatic Headlights.....	76
Panel Lighting Control.....	76
Interior (Dome) Lights.....	76
Hazard Warning Light Switch.....	76
Turn Signal Switch.....	76
Signaling for a Turn.....	77
Lane Change.....	77
HI / LO Beam.....	78
Strobe Light.....	78
Exterior Lamp Check.....	78
Switch Location.....	78
Function.....	78
Activation.....	79
Deactivation.....	79
Three-Position Door Switch.....	82
Opening the Entrance Door.....	83
Opening the Entrance Door Manually.....	83
Electric-Actuated Door.....	83
Air-Actuated Door.....	83
Traffic Warning System.....	83
Electronic Safety Messages.....	84
Eight-Lamp Amber and RED Warning Lights.....	84
Optional Rocker Switches.....	85
WIG WAG Warning System.....	86
Flashing Stop Arm.....	86
Crossing Gate.....	86
Driver Visual Warning Lights and Indicators.....	87
Audible Warning Buzzer.....	87
Post-Trip Inspection (No Student Left Behind).....	87
System Purpose.....	87
System Function.....	87
System Activation.....	87
System Deactivation.....	88
Snooze Mode.....	88
BUS-SCAN® 100 System.....	89
Unloading Students With Engine Off.....	89
Wheelchair Lift Operation.....	90
Wheelchair Lift Interlocks – Extending.....	90
Wheelchair Lift Interlocks–Retracting and Stowing.....	90
Wheelchair Lift Alarm.....	91
Emergency Exits.....	91
Emergency Door.....	91
Emergency Exit Windows.....	92
Horizontal Emergency Exit Window.....	92
Vertical Emergency Exit Window.....	92
Roof Vent / Hatch.....	93

### Section 6 – Passenger Control

Door Opening / Closing.....	81
Opening / Closing.....	81
Two-Position Door Switch.....	82



**Section 7 – Seating and Safety Restraints**

Driver Seat Adjustment.....95  
 Seat Height Adjustment.....96  
 Optional Air Suspension Seat.....97  
 Driver Seat Belts.....98  
 Driver’s Adjustable Lap and Shoulder (Three-Point) Belt.....98  
 Seat Belt Tether.....99  
 Tether Adjuster Procedure.....99  
 .....99  
 Adjusting the Length of the Tether.....100  
 .....100  
 Care of Seat Belts.....100  
 Inspection of Seat Belts.....101  
 Seat Belt Cutter.....101  
 Passenger Seat Belts.....101  
 Passenger Two-Point Seat Belt (Lap Belts).....102  
 Passenger Three-Point Seat Belts (Optional).....102  
 Buckling Up.....102  
 Unbuckling.....103  
 39 Inch Flex Seat.....104  
 Integrated Child Restraint Seats (Optional).....104  
 CE White Integrated Child Restraint Seats (Optional).....107  
 .....109  
 Child Restraint Anchorage Systems (Optional).....109  
 Location and Use of Lower LATCH Anchors.....110  
 Location of the Tether Anchor (Optional).....110  
 IMMI® Seats Tether Installation.....111  
 Location and Use of Tether Anchors (BTI Bus Seats).....111  
 Installing Tether.....111  
 Location and Use of Tether Anchors (SafeGuard®  
 XChange Bus Seats).....112  
 Cushion Release Latch.....112

Track Seat Mounting Seat Type Specific.....114

**Section 8 – Climate Controls**

Heater System.....119  
 Driver Heater.....119  
 Auxiliary Heaters.....120  
 Defrost Operating Instructions.....120  
 Auxiliary Fuel-Fired Heater System (Optional).....120  
 Introduction.....120  
 Description.....121  
 Operation.....121  
 Heater Control Switch.....121  
 Heating Mode.....122  
 Switching-Off Sequence.....123  
 Air Conditioning.....123  
 Integrated Air Conditioning System (IC Air).....123  
 Circulation Fans.....124  
 Heater Booster Pump.....125  
 Heater Cut-Off Valve.....125

**Section 9 – Operation**

Starting Procedures.....127  
 Starting the Engine.....127  
 Automatic Transmission Starter Interlock.....128  
 After the Engine Starts.....129  
 Engine Features.....129  
 Fuel.....130  
 Ultra-Low Sulfur Diesel Fuel Requirements.....130  
 Unacceptable Fuel Blends.....130  
 Hazards of Diesel Fuel / Gasoline Blends.....130

## Table of Contents

---

Additional Unsafe Practices.....	131	Split-System Feature.....	148
Fuel and Lubricant Additives.....	131	Warning Indicators.....	148
Fueling Procedures.....	131	Power Parking Brake System.....	149
Fueling Precautions.....	132	Air Brakes.....	151
Reserve Fuel.....	132	Air Disc Brakes (0004JBZ, 0004JCC, 0004WEY, 0004WEZ).....	151
Restarting After Running Out of Fuel.....	132	Using Air Brakes.....	152
Engine Brake, Exhaust Brake, or Retarder (Optional).....	132	Using the Air Parking Brake.....	152
Engine and Exhaust Brake Systems Operation.....	132	Parking Brake Indicator Light.....	153
Operational Modes.....	133	Parking Brake / Wheelchair Lift Interlock and Alarm.....	154
Exhaust Aftertreatment.....	133	Wheelchair Lift Extension Operation.....	154
Selective Catalytic Reduction System (If Equipped).....	133	Parking Brake / Wheelchair Lift Interlock–Retracting and Stowing Operation.....	154
Introduction.....	133	Parking Brake / Wheelchair Lift (Optional) Alarm.....	154
Diesel Exhaust Fluid.....	133	Antilock Braking System (ABS).....	155
DEF Tank.....	134	Antilock Driving Tips.....	156
Low DEF Level.....	134	ABS Self-Check.....	156
DEF Contamination or SCR System Fault.....	137	Pedal Adjustment.....	157
Exhaust Diesel Particulate Filter Regeneration.....	141	Traction Control (If Equipped).....	157
Parked Regeneration Procedure.....	144	International® Ride Optimized Suspension (IROS) (If Equipped).....	158
Regeneration Inhibit Switch.....	144	Automatic Transmission Operation.....	158
Two-Position Regeneration Inhibit Switch.....	145	Standard Allison 1000 PTS Transmission.....	158
Three-Position Regeneration Inhibit Switch.....	145	Allison Transmission Mechanical Lever Shifters.....	159
Restarting After Running Out of Fuel.....	145	Allison Generation IV T-Bar Gearshift Control.....	160
Cold Weather Operation.....	145	Allison Generation IV Push-Button Shift Selector.....	161
Instructions.....	145	Parking the Vehicle.....	161
Engine Idling.....	146	Parking the Bus With Transmission Shift / Wheelchair Lift Interlocks.....	162
Winter Fronts.....	146	Wheelchair Lift Extension Operation.....	162
Hot Weather Operation.....	146	Starting Bus in Motion.....	162
Turning Off the Engine.....	147		
Brakes.....	147		
Downhill Operation.....	147		
Hydraulic Brakes.....	147		
Using the Full Power Brake System.....	147		

Starting Bus in Motion With Transmission Shift /  
 Wheelchair Lift Interlocks .....162  
 Retracting and Stowing Operation.....162  
 Backup Alarms.....163  
 Economy Mode.....163  
 Automatic Transmission Operating Temperatures.....163

**Section 10 – Roadside Emergencies**

Hazard Warning Switch.....165  
 Emergency Equipment (Recommended On-Board).....166  
     Fire Extinguisher.....166  
     First Aid Kit.....166  
     Body Fluid Cleanup Kit.....167  
     Reflective Triangle.....167  
 Fuse / Circuit Breaker Charts.....168  
     Chassis Fuse / Circuit Breaker Chart.....168  
     Body Fuse / Circuit Breaker Panel.....170  
     Typical Interior Fuse Panel Layout.....172  
     Fuse Panel Layout, Sheet 1.....172  
     Fuse Panel Layout, Sheet 2.....173  
     Fuse Panel Layout, Sheet 3.....174  
     Fuse Panel Layout, Sheet 4.....175  
     Tilt Hood .....176  
     Raising the Hood.....176  
     Lowering the Hood.....177  
     Emergency Starting Using Jumper Cables.....177  
 Towing Instructions.....178  
     Towing Preparation: Air Parking Brakes.....179  
     Towing Preparation: Hydraulic-Powered Parking  
     Brakes.....179  
     Towing Vehicle With Front Wheels Suspended.....180

Towing Vehicles With Rear Wheels Suspended.....180

**Section 11 – Cleaning**

Surface Cleaning.....181  
     General Cleaning, All Surface Types.....181  
     ABS / Plastic.....182  
     Glass.....182  
 Interior.....182  
     Interior Light Bar Cleaning.....182  
     Upholstery Care.....182  
     Flooring.....183  
 Exterior.....183  
     Waxing or Polishing Vehicles.....184  
     Crossing Arm Cleaning.....184

**Section 12 – Maintenance**

Preface.....185  
 Maintenance Guidelines.....185  
 Supporting Your Vehicle for Service.....187  
 Pre-Trip and Post-Trip Inspections.....187  
 Chassis Lubrication.....187  
 Engine Compartment Fluid Check Points.....188  
 Air-Operated Passenger Door Adjustments.....191  
     Door Opening and Closing Speed Adjustment Points...191  
     Pressure Regulator Adjustment.....191  
     Opening Speed Adjustment.....191  
     Closing Speed Adjustment.....191  
     Electrically Actuated Entrance Door Adjustment.....192  
 Axles.....192  
     Front Axle – Inspection and Lubrication.....192

## Table of Contents

---

Front Axle – Normal Maintenance.....	192	Air Restriction Gauge Service .....	203
Front Axle – Alignment.....	193	Chassis-Mounted Charge Air Cooler and Radiator	
Rear Axle – Inspection and Lubrication.....	193	Core Inspection and Cleaning.....	205
Body.....	193	Cooling System.....	205
Brakes.....	194	Gravity-Fill Coolant Method.....	205
General Information.....	194	Coolant and Optional Coolant Filter.....	209
Air Brakes.....	195	Coolant Concentration / Freeze Point.....	209
Brake Inspection and Adjustment.....	195	Anti-Freeze.....	210
Air Dryer.....	196	Fan Clutch.....	210
Air Dryer Desiccant Replacement.....	196	Heater and Coolant Hose Inspection and	
Air Dryer Purge Valve.....	197	Replacement Guide.....	210
Air Dryer Heater.....	197	Frame and Optional Tow Hooks.....	211
Air Reservoir / Tanks Moisture Draining.....	197	Fuel System.....	211
ABS Connections and Sensors.....	197	Fuel Tank Draining and Cleaning.....	211
Hydraulic Full Power Brakes.....	197	Heater System.....	212
Brake Inspection and Adjustment.....	197	Integrated Air Conditioning (IC Air) System.....	212
Brake Fluid Level.....	198	Drive Shaft.....	213
Fluid Precautions.....	198	Suspension (Air and Steel Springs).....	213
Brake Lines, Hoses, and Fittings.....	198	Steering.....	213
Hydraulic Brake Fluid Accumulators.....	199	General.....	213
ABS Connections and Sensors.....	199	Tightening Steering Intermediate Shaft Joint Bolts.....	214
Chassis Inspection.....	199	Lubrication Points.....	214
Electrical.....	199	Power Steering.....	215
Alternator–Starter–Battery Test.....	199	DEF Tank Filling.....	216
Terminal Inspection–Cleaning–Corrosion Protection.....	199	Exhaust Diesel Particulate Filter (DPF).....	217
Accessory Feed Connections.....	200	Regeneration.....	217
Engine.....	200	Cleaning.....	217
General.....	200	Transmission.....	217
Engine Fluids and Contaminated Material.....	201	Transmission Fluid Level.....	217
Scheduled Maintenance.....	201	Tires.....	218
Air Induction System.....	202	Tire Warnings.....	218
Air Cleaner Element Service.....	202	Tire Maintenance.....	219

**Table of Contents**

Checking Inflation.....219  
Underinflation.....220  
Inspection.....220  
Loads.....220  
Dual Tires Matching.....221  
Dual Tires Mixing.....221  
Rotation.....221  
Rotation Is Advisable.....221  
Tire Replacement.....221  
Wheel and Tire Balancing.....222  
Wear.....222  
Irregular Wear.....222  
Use of Tire Chains.....222  
Wheels.....223  
    Wheel and Wheel Nut Maintenance and Installation....223  
    Wheel Nut Torque Maintenance.....224  
    Hub-Piloted Wheel Installation Procedures.....224  
Windshield Wiper.....225  
    Wiper Blade Assembly Replacement.....225  
Wiper Arm Removal / Replacement.....226  
    Removal.....226  
    Installation.....226

Maintenance Intervals.....227  
Unit Refill Capacities.....238  
    Air Conditioner Refrigerant.....238  
    Cooling System Refill Capacities.....238  
    Diesel Exhaust Fluid Tank.....238  
    Engine Crankcase.....239  
    Full Power Brakes – Brake Fluid.....239  
    Power Steering System.....239  
    Transmission.....239  
Tire and Rim Combinations.....240  
Lubricant and Sealer Specifications.....241  
Torque Specification Charts.....248  
Filter List.....250

**Section 13 – Customer Assistance**

Service Information.....251  
Navistar, Inc., Warranty Program.....251

**Section 14 – Index**

Index.....253

**Table of Contents**

---

---

## SECTION 1 — INTRODUCTION

### Preface

All IC Bus, LLC buses are engineered and manufactured to provide economical and trouble-free service. It is the owner's responsibility to make sure the bus receives proper care and maintenance.

Making modifications to various parts, components and systems of your bus can adversely affect the quality and reliability of your vehicle. IC Bus, LLC does not recommend making modifications to this bus.

This manual provides information needed to understand the operation of your bus and its safety features. It also contains information necessary for the proper operation and maintenance of various bus body and chassis systems.

Do not operate this bus until you are completely familiar with the contents of this manual. Keep this manual in your bus for reference. If you sell the bus, make sure this manual stays with it.

**Optional Features.** This manual describes many optional features that may not be installed in this vehicle.

### Cautions / Warnings / Notes

Cautions, Warnings and Notes are included throughout this manual.

#### CAUTION

**Cautions advise you of the proper care to be taken to prevent damage to your vehicle or property.**



**Warnings advise you of hazards, the consequences, and what to do to prevent them, not only to prevent damage to your vehicle or property, but to help prevent situations and occurrences that could result in personal injury or death.**

**NOTE: Notes indicate an operation, procedure or instruction that is important for correct service.**

### Vehicle Identification

It is important that you record the Vehicle Identification Number (VIN), Component Code Numbers, and Serial Numbers. Use these numbers to obtain parts and information for your bus.

**NOTE: The following illustration represents a typical VIN tag. The actual VIN tag may vary.**

## Introduction

821280

MANUFACTURED BY  
IC CORPORATION

DATE OF MANUFACTURE 5 MO. 03 YR.

GVWR 12474 KGS( 27500 LBS)  
GAWR FRONT 4536 KGS( 10000 LBS) GAWR REAR 7938 KGS( 17500 LBS)  
WITH 265/75R22.5G TIRES 14 PLY WITH 245/75R22.5G TIRES 14 PLY  
AT 759 KPa( 110 PSI) COLD AT 759 KPa( 110 PSI) COLD  
RIMS .22.5X7.50 RIMS 22.5X7.50

THIS VEHICLE CONFORMS TO ALL APPLICABLE FEDERAL  
MOTOR VEHICLE SAFETY STANDARDS IN EFFECT ON  
THE DATE OF MANUFACTURE SHOWN ABOVE.

VEHICLE IDENTIFICATION NO. 4DRBRAAPX3A953275

VEHICLE TYPE 452308001 SCHOOL BUS BODY# 953275MD

ICB100112

## Assistance Guide

IC Bus, LLC believes that every customer is entitled to the best service, both from the product itself and from the firm who sells and services that product.

If for any reason, you do not feel you are receiving these services for the operation of your vehicle or the sales transaction, return to your selling dealer to correct these matters. If the matter is not resolved at that time:

- Contact a member of management at the Dealership to discuss the details of the difficulty. In most cases a problem can be resolved to your satisfaction by the owner or manager.

When parts are required, always provide the Component Code Number, vehicle model and Vehicle Identification Number. Ask your salesperson to assist you in obtaining this information.

For more information not given in this manual, or if you require services of trained service personnel, we urge you to contact a nearby IC Bus or International dealer or phone 1-800-44-TRUCK (87825) for assistance.

## Component Code Numbers

Code numbers are the basis for identifying the components used on your IC Bus, LLC bus. They are used by sales personnel to order the bus, by manufacturing to build it, and by parts to service the bus. Many items in this manual are identified by codes.

Code numbers are a combination of numbers and / or letters. These codes are listed on the Vehicle Line Set Ticket which is sometimes called the Vehicle Specification Card or Code Sheet.

## Line Set Ticket

Each vehicle has a Line Set Ticket (Code Sheet) which lists the identification code numbers of components used to build the vehicle.

A copy of the Line Set Ticket is included in the literature provided with the vehicle. When replacement parts are required, use this copy to positively identify vehicle components to make sure you get the correct parts.

## Vehicle Storage Instructions

When a vehicle is not used for an extended period of time, precautions must be taken to prevent deterioration of vehicle components. Vehicles that are out of service for extended periods of time can experience corrosion and other undesirable



effects. Drive vehicle monthly to exercise the brakes, driveline and steering. Run the vehicle long enough for the engine to reach operating temperature.

**NOTE: Losses occurring to a unit while it is in storage will not be considered for warranty reimbursement.**

### **Storage Duration – One Month or Less**

1. Wash vehicles as necessary. Always wash vehicles that have been exposed to road salt.

**NOTE: Washing Instructions - Wash the vehicle with warm water and mild soap, then wipe wet surfaces with a chamois or soft cloth. DO NOT use hot water or strong soaps or detergents. DO NOT wash the vehicle in direct sun, or when the sheet metal is hot to the touch. This will streak the finish. DO NOT wipe dirt off dry surfaces, as this will scratch the finish.**

**NOTE: When vehicles are stored outside, particularly in coastal areas (salt water and high humidity atmosphere) or other areas of corrosive environment, paint and bright metal may require frequent washing and waxing to prevent deterioration. Determining washing frequency is the customer's responsibility.**

**NOTE: For vehicles exposed to ultraviolet rays of the sun, apply a coating of Bon-Ami® soap, or similar product, to the inside surfaces of the windshield and windows, to shade the interior and prevent fading of the interior trim.**

2. Inspect painted surfaces; touch up all exposed primed or raw metal areas to prevent rust.
3. Apply a thick coat of wax to prevent discoloration from the elements; wax all chrome and stainless steel metal parts.
4. Check the radiator coolant for proper level and adequate freeze protection (-29°C [-20°F] is standard for medium duty models and bus chassis; -40°C [-40°F] is standard for heavy duty models.)
5. Cover open ends of vertical exhaust stack(s).
6. Drain air brake reservoirs and close the drain cocks.
7. Lubricate all exposed transmission, auxiliary transmission, and PTO shift rails.
8. Check state-of-charge eye in batteries and re-charge if open circuit voltage is below 12.6 volts. Disconnect battery ground cables to prevent accidental starting, or parasitic electrical loads from discharging the battery.

### **Storage Duration—Over One Month**

Units in storage longer than one month should be driven until the engine reaches operating temperature:

1. Make sure all tires are inflated properly, remove vertical exhaust stack covers, and reconnect batteries.
2. Check all vehicle fluid levels and fill as required.
3. Start and run the vehicle at fast idle, until it reaches operating temperature. To remove surface charge from the battery, built up from previous start-ups and short idle periods,

## Introduction

---

operate the heater and / or air conditioner, headlights, and other accessories for several minutes.

4. Turn off heater and / or air conditioner and any other accessories; shut off the headlights. Park the vehicle and shut off the engine.
5. Perform the procedure for **Storage Duration - One Month or Less**, if returning the vehicle to storage.

**NOTE: After every 30 additional days of storage, perform items 1 through 5.**

### Storage Facilities

1. Whenever possible, store vehicles indoors, protected from sunlight, in a dry, well ventilated area. If indoor storage is not available, select storage lots to eliminate conditions that cause deterioration.
2. Park away from transformers and / or electrical motors, because when the protective wax in tire compound cracks, ozone in the air attacks the exposed areas.
3. Park away from trees, high weeds and / or grass to prevent damage from tree or weed sap, and to minimize bird and insect stains.
4. Park away from railroad tracks, paint shops, smoky industrial areas, and locations of possible road splash contact.
5. If a vehicle is parked on an incline, install wheel chocks.

### Diesel Exhaust Fluid (DEF) Storage

Diesel Exhaust Fluid has a limited shelf life, both in the vehicle's diesel exhaust fluid (DEF) tank and in storage containers.

The following conditions are ideal for maintaining DEF quality and shelf life during prolonged transportation and storage:

- Storage temperature between 23°F and 77°F (-5°C and 25°C)
- Store in sealed containers to avoid contamination
- Avoid direct sunlight

Long term in vehicle storage (in excess of 6 months) is not recommended. If long term storage is necessary, periodic testing of the Diesel Exhaust Fluid is recommended to ensure proper DEF concentration.

### Reporting Safety Defects

#### U.S. Registered Vehicles

If you believe that your vehicle has a defect which could cause a crash or could cause injury or death, you should immediately inform the National Highway Traffic Safety Administration (NHTSA) in addition to notifying IC Bus, LLC.

If NHTSA receives similar complaints, it may open an investigation, and if it finds that a safety defect exists in a group of vehicles, it may order a recall and remedy campaign. However, NHTSA cannot become involved in individual problems between you, your dealer, or IC Bus, LLC.

To contact NHTSA, you may either call the Auto Safety Hotline toll-free at 1-800-424-9393 or write to: NHTSA, U.S. Department of Transportation, Washington DC 20590. You can also obtain other information about your motor vehicle safety from the hotline.

### **Canadian Registered Vehicles**

If you believe that your vehicle has a defect which could cause injury or death, to the operator, passengers or persons outside the vehicle, immediately inform Transport Canada in addition to notifying IC Bus, LLC.

To contact Transport Canada, you may call 800-333-0510. You can also write to: Transport Canada, Motor Vehicle Defect Investigation, 2780 Sheffield Road, Ottawa, Ontario K1G 3V9.

### **Safety Recalls and Authorized Field Changes**

Safety Recalls and Authorized Field Changes are two campaigns that are used to notify owners of modifications that may involve their vehicle. If you receive such notification, PLEASE FOLLOW ALL INSTRUCTIONS PROVIDED IN THE CUSTOMER LETTER. If your vehicle is part of a Safety Recall campaign, the recall service procedure must be completed to ensure safe operation of your vehicle. As a vehicle owner, you must provide IC Bus, LLC dealers with address corrections and changes to ensure that you receive all notifications. Please verify that your IC Bus, LLC dealer has your correct address. Dealers also have a record of any outstanding campaigns that affect your vehicle.

## **Emission Control Systems**

**NOTE: Federal and California Emission system warranties are found in your Engine Operation and Maintenance Manual.**

### **HD-OBD Foreword**

Heavy Duty On-Board Diagnostics (HD-OBD) is a U.S. Government mandated standard for all 2013 and later Class 4 and above vehicles with a Gross Vehicle Weight Rating (GVWR) of 14,001 pounds or more. The HD-OBD system monitors the engine and aftertreatment systems to verify they are operating within emissions limits. If an emissions fault is logged, the Malfunction Indicator Lamp (MIL) will illuminate and one or more fault codes will be set.

The HD-OBD system operates similarly to previous power train control systems by storing fault codes and turning on the MIL. If the problem that caused the fault goes away, the code will clear and the MIL will go out after certain operating conditions have been met. This may take several times operating the vehicle.

### **Supplemental Federal Emission Control System Warranty**

The United States Environmental Protection Agency adopted new heavy-duty Greenhouse Gas (GHG) vehicle regulations on September 15, 2011. This vehicle may be certified to the GHG regulations. For certified vehicles, additional GHG emissions control system warranty covers certain vehicle components. This Supplemental GHG Federal Emission Control System Warranty coverage for these vehicle components will be managed according to current Federal Emission Control System

## Introduction

---

Warranty process. The GHG emission control system warranty applies to the below listed vehicle components such that they meet the following two conditions:

1. The vehicle and / or GHG emission control system component is designed, built, and equipped so it conforms at the time of sale to the ultimate purchaser with the requirements of the GHG regulations and such component is an emission control and appears on the GHG vehicle emission certification label, and
2. The vehicle and / or GHG emission control system component is free from defects in materials and workmanship that cause the vehicle to fail to conform to the GHG requirements during the applicable supplemental warranty period.

### **GHG Emission Control System Warranty Period**

The GHG emission control system warranty period begins on the date the new GHG certified vehicle is delivered to you. The period of coverage is the greater of the base mechanical warranty or:

- Five (5) years or 50,000 miles, whichever comes first, for spark-ignition and light heavy-duty diesel vehicles with GVWR below 19,500 pounds.
- Five (5) years or 100,000 miles, whichever comes first, for medium and heavy heavy-duty vehicles with GVWR equal to or greater than 19,500 pounds.
- Two (2) years or 24,000 miles, whichever comes first, for tires.

### **Additional Components Covered**

#### **Applies to all certified models:**

The GHG emission-related warranty covers the following components such that they meet the two conditions listed above: 1) Hybrid system components (where applicable), 2) Components whose failure would increase a vehicle's evaporative emissions (for vehicles subject to evaporative emission standards) and 3) Tires.

#### **Applies only to certain certified Fifth wheel equipped ProStar®, LoneStar®, TranStar®, DuraStar®, and 9900 models:**

The GHG emission-related warranty covers 1) Vehicle speed limiters, 2) Idle shutdown systems, and 3) Fairings to the extent such emission-related components are included in the certified emission controls and are listed on the vehicle GHG certification label. The GHG emission-related warranty covers all components whose failure would increase a vehicle's emissions of air conditioning refrigerants for vehicles subject to air conditioning leakage standards.

#### **Applies only to certified vehicles equipped with innovative technologies:**

The GHG emission-related warranty covers components certified as innovative technologies which are part of the certified emission controls. Please contact your authorized International Dealer for further information.

### **Supplemental Federal Emission Control System Maintenance, Repair, and Replacement**

Your vehicle may comply with the Greenhouse Gas (GHG) regulations adopted by the Environmental Protection Agency

on September 15, 2011. As owner or operator of a GHG compliant vehicle, your vehicle and GHG emissions control system components should be properly maintained in good working order.

Repair and replacement of GHG emission control system components should be done to original vehicle manufacturers' specifications to ensure proper function of the vehicle. Tire

replacement should be to tires with GHG emission performance as good, or better, than tires originally equipped on the vehicle. Consult with the tire manufacturer for tire specifications.

The United States Environmental Protection Agency allows limited modification of your vehicle and its GHG emission control system components. Please refer to applicable regulations for allowable and prohibited modifications.



## SECTION 2 — VEHICLE INSPECTION GUIDE

### Introduction

A pre-trip inspection, in accordance with Commercial Driver License (CDL) regulations, the Department of Transportation (DOT) and state regulations, is absolutely necessary before you can begin the first route of the day. The routine can vary from bus to bus, but it is essential to have a routine and stick to it. The following inspections may include checks that are in addition to the CDL requirements. If the pre-trip inspection reveals a problem, report it to the service department or a qualified technician so that it can be repaired before operating the vehicle.

After returning from your daily routes, you must complete a written inspection report in accordance with CDL regulations. Report any faults that you find, or any problems that occurred during your trip, to the service department so that they can be repaired before the next trip.

**NOTE: Make sure your bus is in proper operating condition to keep the passengers safe.**

**NOTE: The driver’s window cannot be unlocked from the outside.**

**NOTE: If the buzzers do not activate with the ignition turned ON and the emergency exits open, have the vehicle repaired before placing the vehicle in service.**

**NOTE: Make sure that every emergency exit door and release bar is not blocked.**

**NOTE: The following illustrations are for reference only and may slightly differ from the actual vehicle.**

## Vehicle Inspection Guide

---

### BE / CE Bus Front View

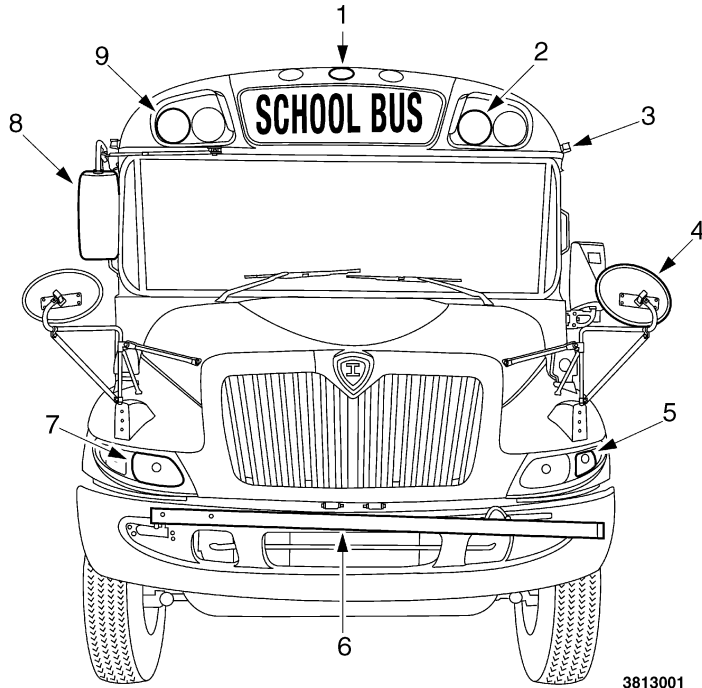

3813001

1. Identification Lamps
2. Amber Warning Lights
3. Clearance Lamps
4. Cross View Mirrors
5. Turn Signals
6. Crossing Gate
7. Headlights
8. Rearview Mirrors
9. RED Warning Lights



BE / CE Bus Rear View

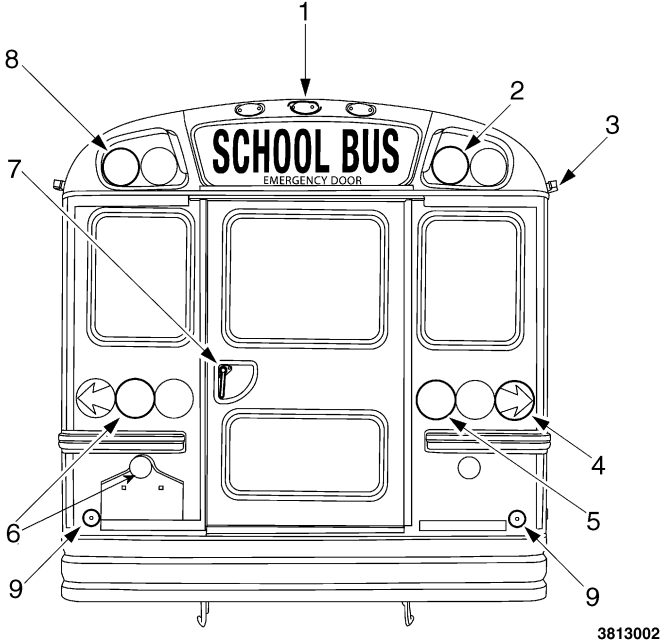

- 1. Identification Lamps
- 2. Amber Warning Lights
- 3. Clearance Lamps
- 4. Turn Signals (With or Without Arrows)
- 5. Backup Lights
- 6. Stop Lights / Tail Lights
- 7. Emergency Door Handle
- 8. RED Warning Lights
- 9. Reflex Reflector

## Vehicle Inspection Guide

---

### BE Bus Right View

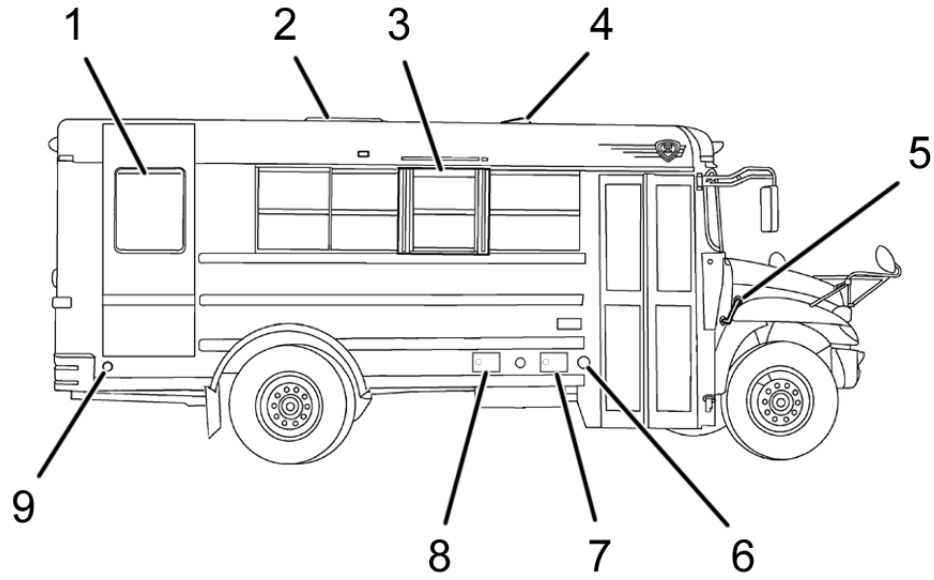

0000055762

- |                                  |                                     |
|----------------------------------|-------------------------------------|
| 1. Optional Wheelchair Lift Door | 6. Reflex Reflector                 |
| 2. Emergency Roof Vent / Hatch   | 7. DEF Fill Door (typical location) |
| 3. Emergency Kickout Window      | 8. Fuel Door (typical location)     |
| 4. Static Vent                   | 9. Reflex Reflector                 |
| 5. Hood Latch                    |                                     |

BE Bus Left View

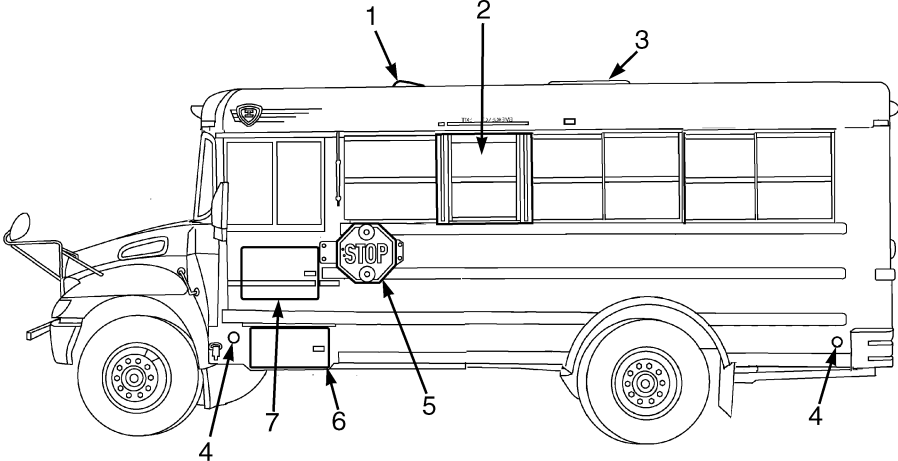

3813044

- 1. Static Vent
- 2. Emergency Kickout Window
- 3. Emergency Roof Vent / Hatch
- 4. Reflex Reflector
- 5. Stop Arm
- 6. Battery Compartment
- 7. Electrical Compartment Access Panel

## Vehicle Inspection Guide

---

### CE Bus Right View

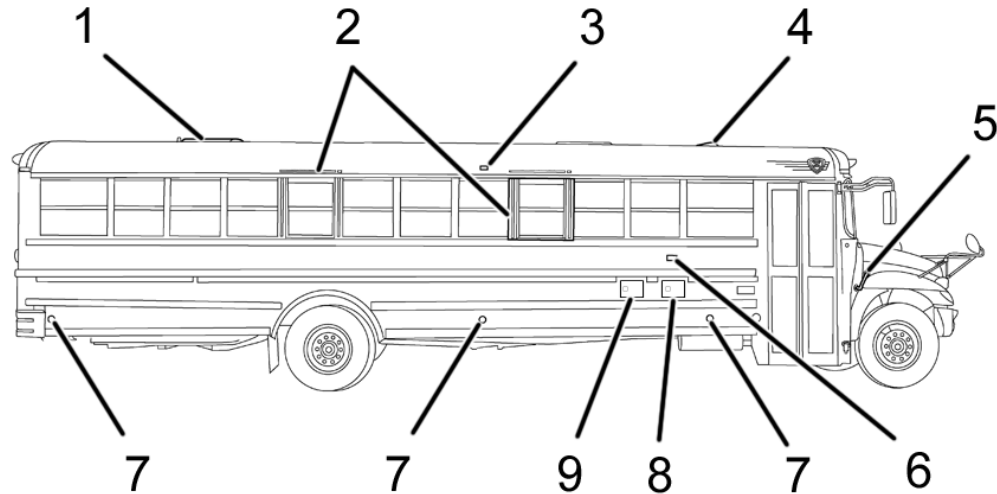

0000055761

- |                                  |                                     |
|----------------------------------|-------------------------------------|
| 1. Emergency Roof Vent / Hatch   | 6. Side Mounted Turn Signal Lamp    |
| 2. Emergency Kickout Window      | 7. Reflex Reflector                 |
| 3. Side Mounted Turn Signal Lamp | 8. DEF Fill Door (typical location) |
| 4. Static Vent                   | 9. Fuel Door (typical location)     |
| 5. Hood Latch                    |                                     |

CE Bus Left View

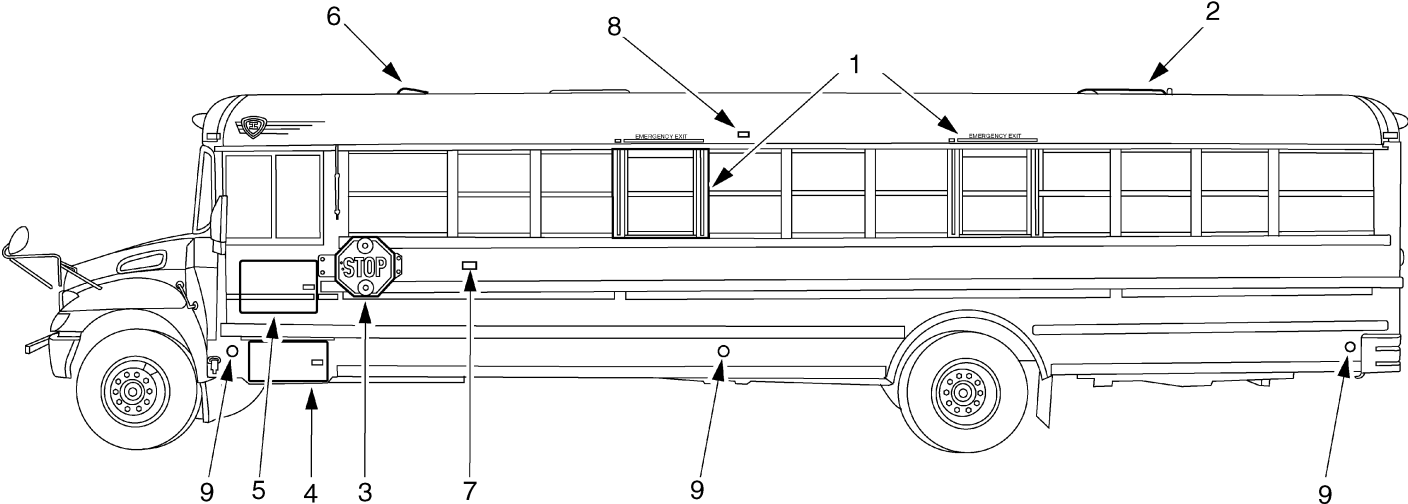

3813004

- 1. Emergency Kickout Window
- 2. Emergency Roof Vent / Hatch
- 3. Stop Arm
- 4. Battery Compartment
- 5. Electrical Compartment Access Panel
- 6. Static Vent
- 7. Side Mounted Turn Signal Lamp
- 8. Intermediate Side Marker Lamp
- 9. Reflex Reflector

## Inspection Check Lists

### Exterior Checks



To prevent property damage, personal injury, and / or death, turn off engine and set the parking brake anytime you leave the vehicle. **NEVER LEAVE THE VEHICLE UNATTENDED WITH ENGINE RUNNING.**

**Table 1 Exterior Checks**

Walk-Around Inspection	Look and listen for leaks and puddles as you walk up to the bus. Check for vandalism and loose items under the vehicle. Check the fuel door and the fuel tank cap. Review the results of the previous post-trip inspection with your supervisor or previous driver. Check all previously noted items to make sure that all requested repairs have been made.
Leaks	Check for signs of fluid leaks in the engine compartment. Also check for signs of drips on the ground under the engine.
Outside Mirrors	Make sure the outside view is not obstructed. Check the cross-view and rear-view mirrors for cleanliness. Also make sure the mirrors are intact and properly adjusted.
Battery	<div data-bbox="1031 868 1251 938" data-label="Image"></div> <p>To prevent property damage, personal injury, and / or death, keep lighted tobacco, flames, sparks or other ignition sources away from the batteries. Gas from the battery cells is flammable and can ignite and / or explode. This is particularly true when jumper cables are being used. In addition, inhaling the hydrogen gas produced by the normal operation of the battery could result in partial or permanent damage to the respiratory system.</p> <p>Check the batteries for loose wires or corrosion at the terminals to prevent possible battery or starting failure.</p>

Table 1 Exterior Checks (cont.)

<p>Lights and Reflectors</p>	<p>Turn ON the exterior lamp check system to make sure all exterior lights are working. For operation of the system see <b>Section – 5 Lights</b>. Check the operation of the amber warning lights, red warning lights, and hazard warning lights. If your BE 200 bus has an exterior strobe light, test it as well. Inspect all reflectors, headlights, turn signals, and emergency flashers. Make certain they are clean, firmly attached, and without cracks or breaks.</p>
<p>Wheels and Tires</p>	<div style="text-align: center;">  <p><b>WARNING</b></p> </div> <p><b>To prevent property damage, personal injury, and / or death, if wheels or tires must be changed, obtain expert tire service help. Mounting and dismounting of tires should only be performed by qualified personnel using necessary safety procedures and equipment.</b></p> <p>Inspect all wheels and tires for any obvious defects, damage, or excessive tread wear. Check tires for the proper inflation. Check wheel or rim nuts for tightness and condition. If equipped with front oil type wheel bearings, check for proper oil level.</p>
<p>Rear Axle and Wheel Bearings</p>	<p>Check for obvious leaking on outside or inside of wheel. Inspect axle flanges and wheel seals for leaks and loose mounting hardware, or broken items. Check lube level, if equipped with sight glass.</p>

# Vehicle Inspection Guide

---

## Front Suspension



To prevent property damage, personal injury, and / or death, do not operate vehicle if there is a loss of steering or suspension, which could result in a loss of vehicle control.

**Table 2 Front / Rear Suspension**

Springs	Look for missing, broken or shifted leaves, or leaves that are in contact or nearly in contact with the tire, wheel, brake drum, brake chamber, frame or body.
Spring Mounts	Check the spring hangers, bolts, bushings, axle mounting U-bolts and nuts for cracks, breaks, wear, damage, tightness, and missing hardware. For proper torque, refer to the torque charts in the Maintenance section.
Shock Absorbers	Check for cracks, leaks, and missing or broken mounting bolts or bushings.

## Brakes

**Table 3 Brakes**

Drum or Rotor and Brake Linings	Check to see that there are no cracks, dents or holes and no loose or missing bolts. Check to see that the brake linings, where visible, are not worn thin or contaminated by lubricant.
Hoses	Check for secure couplings and for cracked, worn or frayed hoses.
Chamber (Air Brakes Only)	Check to see that the brake chambers are not cracked or dented and that they are securely mounted.
Slack Adjuster (Air Brakes Only)	Check for broken, loose or missing parts: angle between push rod and adjuster arm should be approximately 90 degrees when the brakes are applied.
Air Wet Tank (Air Brakes Only)	Drain water daily.



Underhood and Fluid Checks



To prevent property damage, personal injury, and / or death, maintain adequate clearance between all parts of the exhaust system and all hoses, wires, and lines for engine cooling, brake system, fuel system, power steering system, and electrical system. Heat damage to hoses and wires may cause vehicle malfunction.



To prevent property damage, personal injury, and / or death, if vehicle is equipped with an automatic transmission, have a qualified technician regularly check operation of transmission neutral start switch. If unit starts in gear, the vehicle may inadvertently move.



To prevent personal injury or death from hot coolant or steam scalding, use the following procedure to remove the pressure cap from the de-aeration tank:

- A. Allow the engine to cool.
- B. Wrap a thick cloth around pressure cap.
- C. Partially unscrew pressure cap slowly while firmly holding cap down, then pause to allow pressure to release.
- D. When system pressure is released, fully unscrew pressure cap while continuing to hold cap down. Slowly release downward pressure from pressure cap.
- E. Remove cap.



To prevent property damage, personal injury, and / or death, exercise care when working on vehicles with running engines that are equipped with an automatic fan clutch. The fan engages when engine coolant reaches a predetermined temperature or the refrigerant pressure (if equipped with air conditioning) reaches a predetermined setting. The fan will start with no advance warning.

## Vehicle Inspection Guide

---

**Table 4 Underhood and Fluid Checks**

Belts	Open the hood and check that the water pump, alternator, and A/C compressor belts are not frayed and have no excessive cracking, loose fibers, or other signs of wear. Make sure they are snug and secure.
Fan Cooling Ring and Shroud	Check for security of engine-mounted fan cooling ring and fan shroud.
Engine Oil	Use the engine oil dipstick to verify that the engine oil level is correct. Refer to the engine manual for the correct fluid and lubricant specifications.
Automatic Transmission Fluid	With the engine running, use the dipstick to make sure the correct transmission fluid level is present. Refer to the Allison Transmission Manual for correct fluid and lubricant specifications.
Engine Coolant	Make sure the fluid is between the ADD and MAX fluid level range as marked on the reservoir. Do not remove the pressure cap until the coolant has cooled; failure to do so may result in personal injury. If additional fluid is necessary, see the Maintenance section of this manual to find the correct fluid type before filling.
Windshield Washer System Fluid	Inspect the fluid level through the plastic reservoir. If additional fluid is necessary, see the Maintenance section of this manual to find the correct fluid type before filling.
Power Steering Fluid	Check that the fluid is between the MIN (COLD) and MAX (HOT) marks. If additional fluid is necessary, see the Maintenance section of this manual to find the correct fluid type before filling.
Brake Fluid Check	Check to make sure the brake fluid is between the MIN and MAX lines. If additional fluid is necessary, see the Maintenance section of this manual for the correct fluid type before filling.
Radiator and Charge Air Cooler	Inspect the radiator and charge air cooler for damage and / or blockage. Inspect all radiator and heater hoses.
Hood and Hood Latches	Close and latch the hood. Check that the hood is securely latched in place with the hood latches.

Interior Visual and Operational Checks

Table 5 Interior Visual and Operational Checks

Interior Mirror	Make sure the interior mirror is clean and adjusted to provide a clear view of the entire rear of the bus including the rear windows. To adjust the mirror, loosen the bolts and nuts in the slotted holes. After moving the mirror to the desired position, tighten the bolts and nuts.
Window Operation	Make sure windows are free of dirt, fog, condensation and snow. Make sure the driver and passenger windows can open and close completely.
Engine Starting	With the parking brake applied, insert the key and turn the ignition switch to start the engine. Make sure the gauges perform an On and Off cycle during the engine start up. On vehicles with V-8, wait until the WAIT TO START indicator goes out. On vehicles with the I-6 the WAIT TO START indicator is an available option.
	<b>NOTE: All remaining checks are to be performed with the engine running.</b>
Instrumentation	With engine running, check gauges for oil pressure, temperature, alternator, and fuel levels.
Wiper Blades	Look through the windshield to inspect both wipers for signs of wear, damage, or signs of aging on the rubber blades. Check wiper operation.
Passenger Entry	Make sure the door opens and closes completely. Make sure the entry steps are clear, and the treads are secure and are in good condition.
Heater Leaks / Fans	Inspect for interior heater fluid leaks and check fan operation at all heater locations.
Emergency Devices	Sound the horn. Turn on the heater and defroster. Check the windshield wipers and washers for proper operation. Using cross-view mirrors and another person, or the lamp check system, verify that the front and rear exterior directional signal lights are working. Make sure that all interior lights are working properly.

## Vehicle Inspection Guide

**Table 5 Interior Visual and Operational Checks (cont.)**

Air Brake Check	<p>Check the air brakes accordingly:</p> <ul style="list-style-type: none"> <li>• Block wheels if necessary. Push in parking brake and start engine</li> <li>• Check the air compressor or governor cut-out pressure (approximately 827 kPa (120 psi))</li> <li>• Shut off engine and TURN KEY BACK ON</li> <li>• Without brake pedal applied, note air pressure drop for one minute (It should be less than 14 kPa (2 psi))</li> <li>• Depress and hold brake pedal making sure there is no more than a 21 kPa (3 psi) per minute pressure drop. For combination vehicles, there should be no more than 28 kPa (4 psi) per minute pressure drop.</li> <li>• Step on and off brake pedal and check for warning indicator and buzzer to come on at about 414 or 483 kPa (60 or 70 ± 6 psi)</li> </ul>
Air Brake Check (Cont)	<ul style="list-style-type: none"> <li>• Step on and off brake and check to make sure the parking brake knobs pop out between 138 to 310 kPa (20 to 40 or 45 psi)</li> <li>• Restart engine, shift into a low gear, and gently pull against service and parking brakes separately to make sure they will hold.</li> </ul>
Hydraulic Brake Check	<p>Pump the brake pedal three times. Then apply firm pressure to the pedal and hold for five seconds. The pedal should not move, and the brake pressure indicator should not illuminate.</p>
Accelerator Pedal	<p>Check for smooth, non-binding pedal action.</p>
Shift Selector	<p><b>NOTE: Foot brake pedal must be pressed to shift out of the (P) Park position.</b></p> <p>Check for proper functioning of the shift selector and linkage.</p>
Parking Brake Check	<p><b>NOTE: Foot brake pedal must be pressed to release the parking brake and to shift out of the (P) Park position.</b></p> <p>With foot on brake pedal, shift the transmission into a forward gear. Take your foot off the service brake pedal, and allow the bus to idle forward. If the bus moves forward, the parking brake has malfunctioned. Stop the bus with the service brake and have the vehicle serviced immediately.</p>

**Table 5 Interior Visual and Operational Checks (cont.)**

(Optional) Backup Alarm Check	Check for proper operation of the Backup alarm. See Driver Section for Backup alarm operation.  <b>NOTE: Foot brake pedal must be pressed to release the parking brake and to shift out of the (P) Park position.</b>
Optional Wheelchair Lift System Operational Check	Inspect the optional wheelchair lift system for proper operation every day. Refer to the lift manufacturer’s operators manual for items that should be checked before operation.

**Integrated Air Conditioning System (IC Air)**

**Table 6 Integrated Air Conditioning System (IC Air)**

Compressor Belts	Check for tension and wear.  Inspect for properly tensioned belt. This ensures maximum compressor performance and belt life.
Evaporator Filters	Check for cleanliness.  A properly maintained filter maximizes air flow and system performance.
Hoses	Check that hoses are secured and protected.  Prevents the possibility of refrigerant leaks.
Wiring Harnesses	Check that hoses are secured and protected.  Prevents the possibility of electrical shorts.
Condenser Coil	Check for cleanliness.  A properly maintained condenser coil will ensure maximum heat transfer and system performance.
Sight Glass Moisture Indicator	Check color of sight glass: <ul style="list-style-type: none"> <li>• Deep Green = Absence of moisture</li> <li>• YELLOW = Moisture is present <b>IMMEDIATE SYSTEM SERVICE REQUIRED</b></li> </ul>

## Vehicle Inspection Guide

---

### Auxiliary Fuel-Fired Heater System

**Table 7 Auxiliary Fuel-Fired Heater System**

Coolant hoses, clamps, and valves	Check that hoses are secured and protected. Check for clamp tightness. Make sure valves are open.
Coolant level	Maintain the engine manufacturer's recommended coolant level, and make sure that the heater is properly bled after service on / or involving the coolant system.
Fuel lines / leaks	Visually check all fuel lines for leaks. Check, and if necessary, replace fuel filter inserts.
Electrical lines and connections	Visually check all electrical lines and connections for corrosion.
Battery system condition	Maintain batteries and all electrical connections in good condition. With insufficient power, the heater will not start. Low and high voltage cutouts will shut the heater down automatically.
Proper fuel	Use fuel suitable for the climate (see engine manufacturer's recommendations). Blending used engine oil with diesel fuel is not permitted. Biodiesel of 5% or less is permitted. Greater levels of Bio-diesel may result in failures to the heater.

### Emergency Exits and Equipment

**Table 8 Emergency Exits and Equipment**

Roof Hatch	Inspect the roof hatch daily for proper opening, buzzer warning, if supplied, and operating instruction decal attachment. Make sure the emergency hatch is completely closed and secure.
Emergency Exits	Check all emergency exits every day for proper opening, buzzer warning, and operating instruction decal attachment. Check to see that all emergency exit doors can be opened, and that they are firmly closed. Make sure all emergency door release bars are properly secured, and the kickout window handle is properly latched.

**Table 8 Emergency Exits and Equipment (cont.)**

<p>Warning Lights, Stop Arm, Crossing Gate, and Entrance Door Check</p>	<p>Check to see that the amber and red warning lights are operating properly. To check these lights use the Exterior Lamp Check procedure in the Lights section of this manual. Make sure the Stop Arm and Crossing Gate are working properly and extend completely. Also make sure the entrance door is opening and closing properly.</p> <p>Check to see that the flasher warning lights and stop arm are working properly with the flasher switches and entrance door operations. Check to see that the Amber Warning Lights are flashing. When the entrance door is opened, check to see that the Amber Warning Lights stop flashing and the RED warning lights begin flashing, and Crossing Gate and Stop Arm are extended. Close the entrance door and observe that flasher warning lights go off. There is an optional feature that will automatically turn off the pupil warning lights after the bus has started to move.</p>
<p>Emergency Equipment</p>	<p>If equipped / required by state law, check to make sure that the fire extinguisher, reflective triangles, first aid kit and body fluid clean up kit are in place and secure.</p>





## SECTION 3 — INSTRUMENTATION

### Instrument Panel Gauge Cluster

The instrument panel gauge cluster includes the instrument gauges, warning indicators, and an Integral Digital Display, which will provide odometer, transmission gear indication, and

compass heading and outside temperature displays. This instrument panel gauge cluster displays the crucial operational functions of the vehicle. The following are descriptions and illustrations of the gauges, warning indicators, and integral digital display options.

# Instrumentation

For Vehicles NOT Equipped with Selective Catalytic Reduction (SCR) System:

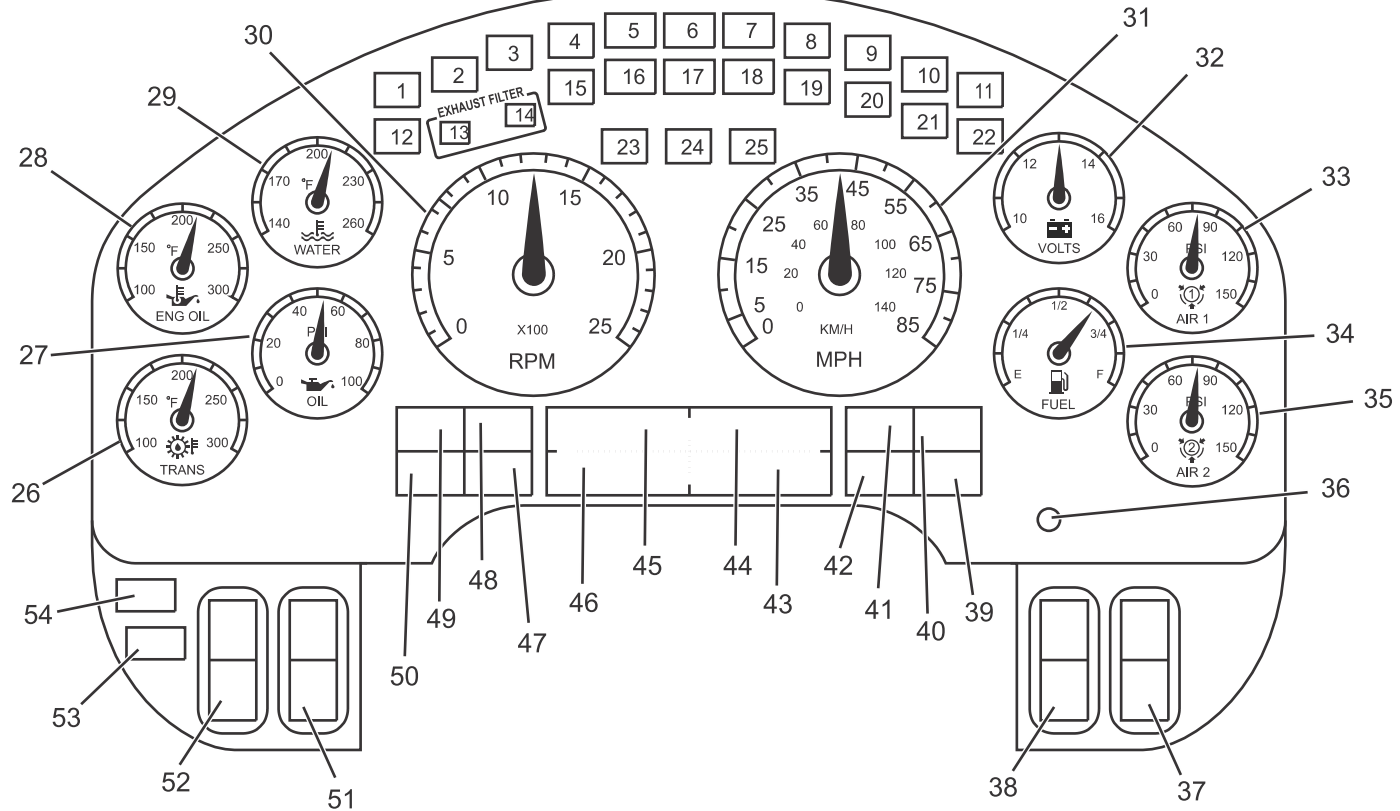

0000037191

For Vehicles Equipped WITH Selective Catalytic Reduction (SCR) System:

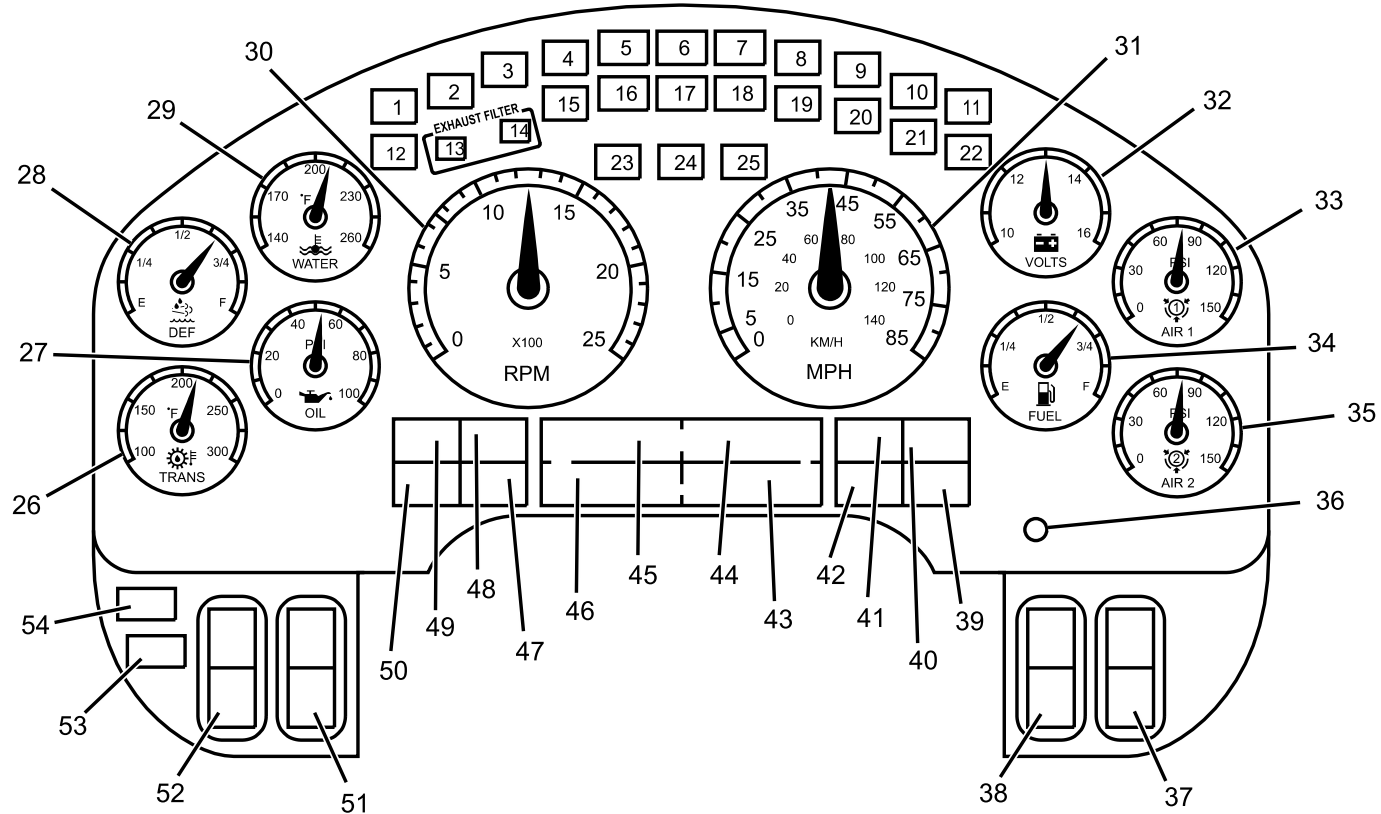







0000055747

## Instrumentation





### Warning Indicators

The instrument panel gauge cluster may contain as many as 25 individual LED warning indicators. These indicators are used to alert the driver of vehicle conditions and functions and may indicate a WARNING or STOP condition. They are turned on by the software in the instrument panel gauge cluster. At ignition, the warning indicators will illuminate for 8 to 10 seconds, as part of the vehicle power-up sequence.



Item No.	Item	Description
1	 3813045	<p>Optional Wait to Start Lamp</p> <ul style="list-style-type: none"> <li>• Illuminates <b>YELLOW</b> when intake air heaters and glow plugs are in operation and special starting procedures are required. Duration of Wait to Start will vary upon ambient air temperature.</li> <li>• Flashes <b>YELLOW</b> when optional engine starting protection activated. Optional feature prevents engine cranking to cool starter motor and prevent burn out. Once starter motor has cooled, normal function is restored.</li> </ul>
2	<b>IDLE SHUT DOWN</b> 8487074	Illuminates <b>YELLOW</b> to alert driver that vehicle idle shutdown timer will turn engine off in 30 seconds.





3	 8487080	Illuminates <b>YELLOW</b> . Used in conjunction with other Warning indicators or General Text and Warning Messages and may be accompanied by an audible alarm to indicate an Alert condition to the operator.
4	 8487084	AWL-The <b>AMBER</b> Warning Lamp (AWL) illuminates when the vehicle needs to be serviced at the first available opportunity.
5	 8487086	RSL-The <b>RED</b> Stop Lamp illuminates RED when a serious problem has occurred. This lamp is accompanied by a message on the odometer display and an AUDIBLE ALARM. If the RED Stop Lamp illuminates, immediately pull the vehicle safely off the roadway, turn on the flashers,, set the parking brake, place warning devices and stop the engine. The engine should not be restarted prior to being serviced.!
6	<b>BRAKE</b>  <b>PRESSURE</b> 3813046	Illuminates <b>RED</b> when a failure in the service brake system has occurred. If the Brake Pressure warning indicator illuminates, safely stop the vehicle as soon as possible and seek service immediately.
7	<b>PARK</b>  8487075	Illuminates <b>RED</b> when the parking brake is applied. If the brake warning indicator does not illuminate, or if it stays on with the parking brake not engaged, seek service immediately.

8	<b>EMERG EXIT</b> 8487079	Illuminates when the emergency exit is not securely closed when the key switch is in the Accessory or ON position.
9	<b>RANGE INHIBITED</b> 8487070	Illuminates <b>YELLOW</b> when the transmission is not engaged in the selected gear. The warning indicator goes out when the gearshift lever is adjusted to the appropriate gear. Refer to the Transmission Operator Manual for more information.
10	<b>LIFT DOOR</b> 8487083	Illuminates <b>YELLOW</b> when the optional lift door is not securely closed when the key switch is in the ON position.
11	 3813047	Illuminates <b>YELLOW</b> when the traction control system is turned off. It also illuminates momentarily when the traction control system is on and is limiting wheel spin. Blinks on if slippery road conditions may exist. If this happens, adjust your driving accordingly. Refer to the Driving section for more information.

12	 0000036013	For vehicles not equipped with Selective Catalytic Reduction (SCR) system: this field is not in use.  For vehicles equipped with Selective Catalytic Reduction (SCR) system: Illuminates <b>YELLOW</b> (Solid or Flashing) when the Diesel Exhaust Fluid (DEF) level is low.  For details, see <b>Exhaust Aftertreatment &gt; Selective Catalytic Reduction</b> .
13	 3813051	Illuminates <b>YELLOW</b> when exhaust system components are operating under normal conditions and exhaust gases are at extremely high temperatures.
14	 3813052	Diesel Particulate Filter (DPF) status indicator. Illuminates <b>YELLOW</b> (Solid or Flashing) to indicate the need to regenerate the Diesel Particulate Filter. (See <b>Exhaust Regeneration in the Operation Section</b> )
15	 3813053	MIL-The Malfunction Indicator Lamp (MIL) illuminates when the On-Board Diagnostics (OBD) detects a malfunction related to the emissions control system. The illuminated MIL indicates that the vehicle needs to be serviced at the first convenient opportunity. Lamp may remain active after repair until system operation confirms repair.

## Instrumentation

16	<b>SERVICE</b>  8487088	Illuminates <b>RED</b> when a parking brake system malfunction has been detected. If the Service Parking Brake indicator stays illuminated, have the system serviced immediately.
17	 8487073	Optional indicator illuminates <b>RED</b> immediately after ignition is turned on to remind operator to fasten seat belt.  Optional Seat Belt Reminder with Seat Belt Monitoring causes initial visual indication, then flashes with audible alarm when ignition is on, parking brake is released, and seat belt is not fastened.
18	<b>BRAKE FLUID</b>  3813054	Illuminates <b>RED</b> when the brake fluid falls below the safe operating level.
19	<b>RED FLSHR</b> 3813049	Illuminates when the red flasher warning lights are activated.
20	<b>AMBER FLSHR</b> 3813048	Illuminates when the amber warning flasher lights are activated.

21	 8487089	Illuminates <b>YELLOW</b> when an antilock brake system malfunction has been detected. If the ABS indicator stays illuminated or continues to flash, have the system serviced immediately.
22	<b>ECON</b> 8487091	Illuminates <b>YELLOW</b> when transmission Economy Mode is selected. Refer to the Transmission Operator Manual for more information.
23	 8487092	Flashes <b>GREEN</b> when the left turn signal or the hazard lights are turned on.
24	 8487094	Illuminates <b>BLUE</b> when the high beam head lamps are turned on.
25	 8487093	Flashes <b>GREEN</b> when the right turn signal or the hazard lights are turned on.

**NOTE: If the MIL is illuminated, it is the vehicle owner's responsibility to have the engine repaired or face fines.**

Instrument Panel Gauge Cluster







To prevent property damage, personal injury, and / or death, never operate the vehicle when insufficient air pressure (less than 70 psi [483 kPa]) is indicated for either the primary or secondary air system. The volume of air required to stop the vehicle may be greater than that available. Have the brake system checked and repaired before returning the vehicle to service.

There are 10 gauges in the instrument panel gauge cluster to help monitor the vehicle while in service. Most gauges have in-gauge warning indicators that turn on if the gauge pointer moves into an out-of-acceptable-range condition. When the ignition switch is turned on, the gauge indicators will be on. Metric versions of the gauges and speedometer are available as an option.

**NOTE:** If any indicator fails to go out after starting engine, stop engine and determine cause of the gauge indication that is out of acceptable range.

26		Indicates the transmission lubricant temperature in degrees Fahrenheit (°F) (optional).
		Indicates the engine lubricant temperature in degrees Fahrenheit (°F) (optional).
27		Indicates engine oil pressure in pounds per square inch (PSI).
28		For vehicles not equipped with Selective Catalytic Reduction (SCR) system: Indicates the engine lubricant temperature in degrees Fahrenheit (°F) (optional).
		For vehicles equipped with Selective Catalytic Reduction (SCR) system: Indicates the approximate DEF level in the DEF tank.
29		Indicates engine coolant temperature in degrees Fahrenheit (°F).
30		The tachometer indicates engine speed (RPM). The engine can be operated between idle speed and high idle speed without damage but should not be allowed to over-speed (such as when going downhill).



## Instrumentation

31		The speedometer indicates the vehicle speed in miles per hour (MPH) and kilometers per hour (km/h).
32		Indicates the battery voltage (VOLTS) when the ignition switch is in the ON position.
33		Provides indication of air pressure available for the primary air brakes in pounds per square inch (PSI).
34		Indicates the approximate fuel level in the fuel tanks.
35		Provides indication of air pressure available for the secondary air brakes in pounds per square inch (PSI).

### Direct Drive Warning Indicators

The Instrument Panel Gauge Cluster also houses eight (8) direct drive warning indicators that alert the operator of various conditions of the vehicle. They are in two groups of four each, located on both sides of the LED quadrant displays. The warning indicators that are not used in this particular model will be **substituted with** a blank cover plate.

**NOTE: There are several variation of Direct Drive Warning Indicators. Actual indicator configuration may vary.**

Item No.	Item	Description
39		Optional transmission fluid / filter change indicator illuminates <b>YELLOW</b> . Refer to Transmission Operator Manual for additional information
40		Illuminates <b>YELLOW</b> when exhaust system components are operating under normal conditions and exhaust gases are at extremely high temperatures.
41		Diesel Particulate Filter (DPF) status indicator. Illuminates <b>YELLOW</b> (solid or flashing) to indicate the need to regenerate the Diesel Particulate Filter. (See Exhaust Regeneration in the Operation Section)
42		Not used
47		Not used.
48		Not used.
49		Not used.
50		Not used.



**Integral Digital Display**

The integral digital display is located below the speedometer and the tachometer. It is arranged in four quadrants that display vehicle information. The four quadrants can be individually selected by using the display control button.

**Display Control.** The Display control is used to scroll to a quadrant and to select the various modes within a quadrant. To navigate between quadrants, turn and release the control either

clockwise or counterclockwise. To select the screens within a quadrant, press and release the control. Pressing and holding the control for more than 3 seconds to reset the value of the selected quadrant parameter (if the parameter can be reset). The selected quadrant is identified by a vertical bar located in the far right of quadrant. In quadrant 1, the odometer screen can be toggled between English and Metric, by pressing and holding the control.

Item No.	Quadrant Number and Message Function	Message Description
36	Display Control	Toggles the information display from one screen to the next when pressed and released.
43	Quadrant 2: General Text and Warning Messages	Displays a variety of messages ranging in priority necessary for vehicle monitoring and operation, and vehicle malfunction warnings. Some messages are used in conjunction with instrument panel gauge cluster warning indicators (see list of messages in the <b>Instrument Panel Gauge Cluster &gt; Integral Digital Display Detailed Information</b> section in <b>Controls / Features</b> ).

## Instrumentation

---

Item No.	Quadrant Number and Message Function	Message Description
44	Quadrant 1: Informational Messages	<p data-bbox="875 212 1207 239">Informational Display Screens:</p> <ul data-bbox="875 259 1375 1045" style="list-style-type: none"><li data-bbox="875 259 1033 286">• Odometer</li><li data-bbox="875 306 1083 333">• Trip Odometer</li><li data-bbox="875 353 1132 380">• Total Engine Hours</li><li data-bbox="875 400 1039 427">• Trip Hours</li><li data-bbox="875 447 1222 474">• Machine PTO A or B Hours</li><li data-bbox="875 494 1271 521">• Machine Trip PTO A or B Hours</li><li data-bbox="875 541 1132 568">• Engine PTO Hours</li><li data-bbox="875 588 1180 615">• Engine PTO Trip Hours</li><li data-bbox="875 635 1238 662">• Instantaneous Fuel Economy</li><li data-bbox="875 682 1228 709">• Trip Average Fuel Economy</li><li data-bbox="875 729 1267 756">• Machine PTO Fuel Used A or B</li><li data-bbox="875 776 1315 803">• Machine PTO Trip Fuel Used A or B</li><li data-bbox="875 823 1174 850">• Engine PTO Fuel Used</li><li data-bbox="875 870 1222 897">• Engine PTO Trip Fuel Used</li><li data-bbox="875 917 1132 944">• Trip Idle Fuel Used</li><li data-bbox="875 964 1375 991">• Axle Load Indication (Front and / or Rear)</li><li data-bbox="875 1012 1238 1038">• Diesel Particulate Filter Level</li></ul>

Item No.	Quadrant Number and Message Function	Message Description
45	Quadrant 4: Transmission Gear Indication	Transmission gears for the Allison P-R-N-D-L gear selection display, or the Eaton® Transmission display.
46	Quadrant 3: Compass Heading / Outside Temperature	<b>(Optional)</b> Displays compass heading when vehicle is equipped with a compass module.  Displays outside temperature (reading is obtained from the temperature sensor).

**Integral Digital Display Detailed Information**

**Quadrant 1: Informational Displays**

**NOTE: The available display screens are dependant on the configuration of the vehicle.**

Quadrant 1 – Display Messages	Description
Odometer	The odometer displays the total distance traveled.  <b>Display Format:</b> 100,000.0 TRIP MILES TRIP KM
Trip Odometer	The trip odometer displays a record of the elapsed distance traveled since the last reset.  <b>NOTE: The trip hours and trip miles are independently reset.</b>  <b>Display Format:</b> 100,000.0 TRIP MILES TRIP KM

## Instrumentation

---

Quadrant 1 – Display Messages	Description
Total Engine Hours	<p>The Engine Hour display provides a record of accumulated engine hours, and will not show any increase unless the engine is running.</p> <p><b>NOTE: This display function cannot be reset.</b></p> <p><b>Display Format:</b></p> <p>100,000.0 HOURS</p>
Trip Hours	<p>The Trip Hour display provides a record of elapsed engine hours since the last reset.</p> <p><b>NOTE: The trip hours and trip miles are independently reset.</b></p> <p><b>Display Format:</b></p> <p>100,000.0 TRIP HOURS</p>
Machine PTO A or B Hours	<p>This display will provide a record of the total accumulated Machine PTO hours, while PTO function A or B is engaged.</p> <p><b>Display Format:</b></p> <p>100,000.0 PTO HOURS A PTO HOURS B</p>
Machine Trip PTO A or B Hours	<p>This display will provide a record of the total accumulated Machine Trip PTO hours, while PTO function A or B is engaged.</p> <p><b>Display Format:</b></p> <p>100,000.0 PTO TRP HOURS A PTO TRP HOURS B</p>

Quadrant 1 – Display Messages	Description
Engine PTO Hours	<p>This display will provide a record of the Engine PTO hours sent from engine.</p> <p><b>Display Format:</b> 100,000.0 ENG PTO HOURS</p>
Engine PTO Trip Hours	<p>This display will provide a record of the Engine PTO Trip hours sent from engine.</p> <p><b>Display Format:</b> 100,000.0 ENG PTO TRP HOURS</p>
Instantaneous Fuel Economy	<p>This display provides a record of the instantaneous fuel economy sent from the engine.</p> <p>The display shall be in miles per gallon or liters per 100 kilometers, corresponding to the units selected while in the odometer mode.</p> <p><b>Display Format:</b> 30.0 INST MPG INST L/100KM</p>
Trip Average Fuel Economy	<p>The display value shall be the average fuel economy value since the last reset of the trip odometer.</p> <p>The display shall be in miles per gallon or liters per 100 kilometers, corresponding to the units selected while in the odometer mode.</p> <p><b>Display Format:</b> 30.0 TRIP MPG TRIP L/100KM</p>

## Instrumentation

---

<b>Quadrant 1 – Display Messages</b>	<b>Description</b>
Machine PTO Fuel Used A and B	The display value shall be the calculated Machine PTO Fuel Used.  <b>Display Format:</b>  100,000.0 PTO GAL A PTO GAL B PTO L A PTO L B
Machine PTO Trip Fuel Used A and B	The display value shall be the calculated Machine PTO Trip Fuel Used.  <b>Display Format:</b>  100,000.0 PTO TRP GAL A PTO TRP GAL B PTO TRP L A PTO TRP L B
Engine PTO Fuel Used	The display value shall be the calculated Engine PTO Fuel Used.  <b>Display Format:</b>  100,000.0 ENG PTO GAL PTO TRP L

Quadrant 1 – Display Messages	Description
Engine PTO Trip Fuel Used	<p>The display value shall be the calculated Engine PTO Trip Fuel Used.</p> <p><b>Display Format:</b></p> <p>100,000.0            ENG PTO TRP GAL            ENG PTO TRP L</p>
Trip Idle Fuel Used	<p>The display value shall be the calculated Trip Idle Fuel Used.</p> <p><b>Display Format:</b></p> <p>100,000.0            TRP IDL GAL            TRP IDL L</p>
Axle Load Indication	<p>The instrument panel gauge cluster shall display an approximate value of Axle Load for the front and / or rear axles.</p> <p><b>NOTE: Axle load readings are most accurate on a level surface with parking brake released.</b></p> <p><b>Display Format:</b></p> <p>approx. 45.0            FT LBSX1000            FT KGX1000            RR LBSX1000            RR KGX1000</p>
Diesel Particulate Filter Level	<p>The instrument panel gauge cluster shall display the relative Diesel Particulate Filter (DPF) Level.</p> <p>The instrument panel gauge cluster displays the following graph:</p>

## Instrumentation

Quadrant 1 – Display Messages	Description
	<div data-bbox="923 198 1400 329" data-label="Image">A rectangular gauge cluster for DPF Load. On the left, it says 'DPF Load'. To its right is a horizontal bar with a vertical line at the far left labeled 'L' and a vertical line at the far right labeled 'H'. The bar contains three dark grey bars of equal height, representing a 30% increase in soot level. Below the gauge is the part number '0487412'.</div> <p data-bbox="589 356 1690 409">With L (low) on the left and H (high) on the right, the graph is shown by bars each representing a 10% increase / decrease in soot level.</p> <p data-bbox="589 436 1709 524">The instrument panel gauge cluster displays the last received level until a new value is received, or until the instrument panel gauge cluster detects that it has not received a response to the SPN request, in which case it shall display the word data n/a within the bar graph.</p>

### Quadrant 2 Text and Warning Messages

These messages inform the driver of vehicle conditions. If the message flashes, it will flash for 3 - 5 seconds, and then will be displayed for an additional 3 - 5 seconds. If more than one message is viewable, the displayed message will be followed by an asterisk (\*), indicating multiple messages. To view additional

messages, press and release the Display Control button to proceed to the next message.

The following is a list of the **routine** Text and Warning messages that can be displayed and is dependant upon the configuration of your vehicle:



Quadrant 2 – Display Messages	Description	Flash (Yes / No)	Warning Indicator Association
PARKD REGEN ACTIVE	Message is displayed during a parked regeneration.	No	No
Washer Fluid Low	Indicates low washer fluid level.	Yes	No
Electrical Fault	When instrument panel gauge cluster's ability to display diagnostic codes is enabled, this message is displayed when there are active diagnostic codes.	Yes	No
Check A/C	Indicates a fault in the HVAC System.	Yes	No
PARKD REGEN INHIBITED	Message is displayed when parked regeneration has been requested, but is not performed due to a vehicle interlock or an engine fault.	No	No
Air Filter Restriction	Message displayed indicates restricted air flow to the engine.	Yes	No
Exterior Lamp Check Active	Message displayed indicates Exterior Lamp Check is in progress.	Yes	No
HVAC Temp Setting	Bar graph displayed show temperature setting in low to high increments.	No	No
Activate HVAC Front Blower	Bar graph displayed show blower speed setting in Off and low to high increments.	No	No
Air Pressure Diagnostic		Yes	No
Cruise	Indicates that the Cruise Control System is turned On.	No	No
Fuel Filter	Indicates that the fuel filter is clogged.	Yes	No
Check Brake Switch		Yes	No

## Instrumentation

Quadrant 2 – Display Messages	Description	Flash (Yes / No)	Warning Indicator Association
Check Pupil Warning Indicator		Yes	No
Check Stop Arm / Crossing Gate		Yes	No
Check Exterior Lamps		Yes	No
Engine Control Shutdown		Yes	No
Engine Control System Error		Yes	No
PARKD REGEN REQUIRED	Indicates parked regeneration is necessary.	No	No
PARKD REGEN INHIBITED ENG TMP	Message is displayed when engine coolant temperature is below 76.6°C (170°F).	No	No
REGEN INHIBIT SWITCH ACTIVE	Message is displayed when Regen Inhibt Switch is On and regeneration Is disabled.	No	No
PARKED REGEN AVAILABLE		No	No
Low Coolant Level	Message is displayed when coolant level is less than or equal to 80%.	Yes	No
Stop Engine	Message is displayed when RED Stop Lamp is illuminated.	Yes	RED Stop Lamp
Warn Engine (Priority 1 or 2)	(1) Message is displayed when MaxxForce® ECM turn on the RED Stop Lamp.  (2) Message is displayed when MaxxForce® ECM requests the AMBER Warning Lamp and not the RED Stop Lamp.	Yes	(1) RED Stop Lamp  (2) AMBER Warning Lamp
Low Engine Oil Level	Message is displayed when engine oil level is less than or equal to 80%.	Yes	No

<b>Quadrant 2 – Display Messages</b>	<b>Description</b>	<b>Flash (Yes / No)</b>	<b>Warning Indicator Association</b>
Change Engine Oil	Message is displayed when engine oil change is detected as necessary.	Yes	No
Water in Fuel	Message is displayed when water in fuel is present.	Yes	No
Electrical Fault (Priority 1 or 2)	(1) Message is displayed when when EGC requests the RED Stop Lamp.  (2) Message is displayed when when EGC requests the AMBER Warning Lamp.	Yes	(1) RED Stop Lamp  (2) AMBER Warning Lamp
Check Trans	Message is displayed when transmission needs to be serviced.	Yes	AMBER Warning Lamp
Trans Temp	Message is displayed when transmission turns on the AMBER Warning Lamp. Not available with all transmissions.	Yes	AMBER Warning Lamp
Gen Trns Flt	Message is displayed when transmission turns on RED Stop, MIL, or PROTECT, or the YELLOW Warning indicator without the conditions to display Check Trans, Trans Temp, Trans Oil Life, Trans Oil Filter, or Trans Service. Not available with all transmissions.	Yes	Yes (see description)
Trans Oil Life	Message is displayed when transmission oil needs changed. Not available with all transmissions.	Yes	No
Trans Oil Filter	Message is displayed when transmission oil filter needs changed. Not available with all transmissions.	Yes	No
Trans Service	Message is displayed when transmission needs service. Not available with all transmissions.	Yes	No
DPF Ash Service Required	Message is displayed when diesel particulate filter ash level requires service / cleaning.	Yes	No

## Instrumentation

Quadrant 2 – Display Messages	Description	Flash (Yes / No)	Warning Indicator Association
See Visor For Info	Message is displayed indicates the particulate trap indicator must be on or must flash.	Yes	Yes (see description)
ECM, TCM, Shift Selector, ABS, Retarder – Driveline, EGC, Compass Module, ESC, VSM, SD, AGSP, TPMS, Exhaust Module, Telematics, AGSP 2, SIC 2, AGSP 3, SIC 1, PAM, Service Tool, Global	Message is displayed when a module other than the engine requests the red stop warning indicator.	Yes	RED Stop Lamp
ECM, TCM, Shift Selector, ABS, Retarder – Driveline, EGC, Compass Module, ESC, VSM, SD, AGSP, TPMS, Exhaust Module, Telematics, AGSP 2, SIC 2, AGSP 3, SIC 1, PAM, Service Tool, Global	Message is displayed when a module other than the engine requests the AMBER Warning Lamp.	Yes	AMBER Warning Lamp
Retarder Temp	Message is displayed when instrument panel gauge cluster receives signal from the Retarder – Driveline requesting the AMBER Warning Lamp.	Yes	AMBER Warning Lamp
Gen Rtrd Flt	Message is displayed when instrument panel gauge cluster receives signal from the Retarder – Driveline requesting the RED warning, MIL, or PROTECT indicator, or the AMBER Warning Lamp without the conditions to display Retarder Temp..	Yes	Yes (see description)
DRV Reward Expected		No	No
DRV Reward Good		No	No
DRV Reward Excellent		No	No

Quadrant 2 – Display Messages	Description	Flash (Yes / No)	Warning Indicator Association
DRV Reward Penalty		No	No
DRV Reward Increasing		No	No
DRV Reward Decreasing		No	No
VSL Ovrđ Active		No	No
VSL Ovrđ Expiring		No	No
	Blank screen, available only when engine rpm less than or equal to 325 RPM, or vehicle speed less than 3 kp/h.	No	No
Calibrate Compass	Message is displayed when vehicle speed is less than 3 kp/h and the operator has not requested Calibrate Compass in the current ignition cycle.	No	No
End Calibration	Message is displayed when vehicle speed is less than 3 kp/h and the operator has requested Calibrate Compass in the current ignition cycle.	No	No
Calibration Ended	Message is displayed when vehicle speed is less than 3 kp/h and the operator has requested Calibrate Compass in the current ignition cycle.	No	No
Declination Zone	Message is displayed only when vehicle speed is less than 3 kp/h.	No	No
DEF Low Refill Soon	Diesel Exhaust Fluid (DEF) needs to be refilled.	No	DEF Level Lamp
DEF Low Eng Derated	Diesel Exhaust Fluid (DEF) level is very low and engine performance is limited.	No	DEF Level Lamp and Amber Warning Lamp (AWL)
DEF Low Eng Derated 5mph	Diesel Exhaust Fluid (DEF) level is 0%. Engine performance is limited and vehicle speed is limited to 5 mph (8 km/h).	No	DEF Level Lamp, Amber Warning Lamp, and Red Stop Lamp

## Instrumentation

---

<b>Quadrant 2 – Display Messages</b>	<b>Description</b>	<b>Flash (Yes / No)</b>	<b>Warning Indicator Association</b>
DEF Quality Service Soon	Diesel Exhaust Fluid (DEF) quality problem is detected.	No	Amber Warning Lamp
DEF Quality Derated	Diesel Exhaust Fluid (DEF) quality problem has been present for 1 hour or longer. Engine performance is limited.	No	Amber Warning Lamp
DEF Quality Derated 5mph	Diesel Exhaust Fluid (DEF) quality problem has been present for 3 hours or longer. Engine performance is limited and vehicle speed is limited to 5 mph (8 km/h).	No	Amber Warning Lamp; Red Stop Lamp

**Warning Messages**

In addition to the Diagnostic Trouble Codes (DTC), the digital display will display a warning message whenever an engine indicator is illuminated. This warning message will be toggled with the normal DTC as follows:

**AMBER Warning Lamp** indicator: WARN ENGINE message

**RED Stop Lamp** indicator: STOP ENGINE message

The following chart provides the warning messages that are displayed along with corresponding Instrument panel gauge cluster indicators.

MaxxForce® Engines	
Warning indicator	Warning Message
RED Stop Lamp	STOP ENGINE
AMBER Warning Lamp	WARN ENGINE

**Outside Temperature and Compass Displays (Optional)**

The optional Outside Temperature and Compass Heading is displayed in Quadrant 3. Typical displays for Temperature and

Compass Heading are listed in the following table. The display provides both the outside ambient temperature and the relative direction of the vehicle within a particular geographical zone. See below for details of calibration and use.

Vehicle must be moving to acquire an accurate temperature.

Quadrant 3 – Display Messages	Description
Outside Temperature and Compass Heading	<p><b>Display Format:</b></p> <div style="border: 1px solid black; padding: 5px; margin-bottom: 10px; width: fit-content;">                     32°F SE                 </div> <div style="border: 1px solid black; padding: 5px; margin-bottom: 10px; width: fit-content;">                     0°C SE                 </div> <div style="border: 1px solid black; padding: 5px; width: fit-content;">                     32°F NO CAL                 </div> <p style="text-align: right; font-size: small;">8590030</p>

## Instrumentation



---

### Outside Temperature Reading

The Outside Temperature is displayed on the first line of Quadrant 3 above the Compass Heading. The temperature sensor is located near the front bumper. Due to its location, the sensor readings can be affected by road or engine heat during idling or prevailing driving conditions (extended slow movement).

The display will be in °F or °C, depending on the units selected while in the odometer mode.

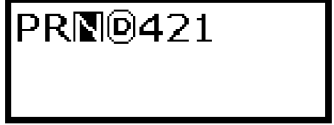
### Quadrant 4: Transmission Gear Displays

Quadrant 4 – Transmission Gear Indications	
Allison P-R-N-D-L gear display	 8487430
Eaton® Transmission display	 8590031



### Optional Instrument Panel Gauge Cluster Compass Calibration Procedure

All new vehicles with an optional compass must have an initial compass calibration performed. A compass calibration may or may not have been completed at the vehicle assembly plant. If the compass headings are noticeably incorrect, or become noticeably incorrect, or the NO CAL message is displayed, the Declination Zone may need to be reset to agree with the current geographic location, or the Compass Directional Calibration will need to be recalibrated.

The compass direction is displayed in the lower left quadrant of the instrument panel gauge cluster display just below the outdoor temperature reading. Text messages necessary to calibrate the compass can be found in the instrument panel gauge cluster display in the lower right quadrant (quadrant 2) of the display. Twist the instrument panel gauge cluster display knob until the cursor is flashing in the lower right quadrant. Press the instrument panel gauge cluster display knob until the desired text message is displayed. Compass Calibration related text messages include Calibrate Compass, Compass Declination, Declination Zone #, and End Calibration.

**NOTE: The Declination Zone for the location where the Compass Calibration procedure is being performed must be set first and thereafter the Compass Directional Calibration procedure can be performed. Both procedures are listed on the following pages and must be followed exactly to ensure proper calibration of the compass.**

### *Compass Declination Zone Set Procedure*

The Declination Zone number is used to account for the errors between magnetic North and true North in the vehicle's geographic operating area, and must be set correctly for the compass to display accurate headings.

**NOTE: When calibrating / recalibrating the compass, you must select the Declination Zone which corresponds to the geographic location where the compass calibration is being performed. It can be reset later to match the Declination zone where the vehicle will be operating.**

For vehicles that regularly operate coast-to-coast or in several different Declination Zones, either choose a Declination Zone in the geographic center of the vehicle's operating area, or change the Declination Zone daily to match the present Declination Zone.



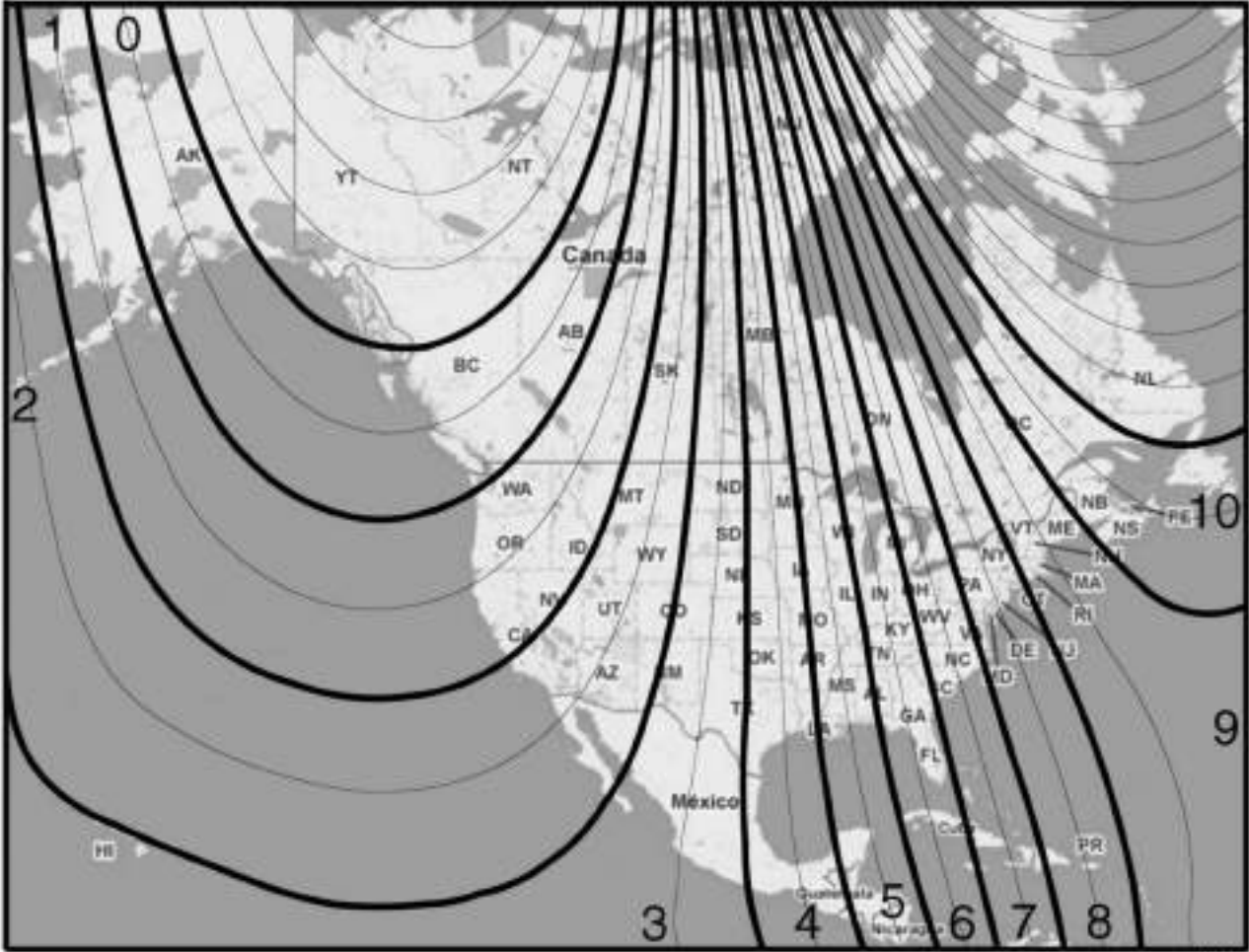

To begin the Declination Zone set procedure, the vehicle must be stopped with ignition key ON. Refer to Zone Map for determining the proper Declination Zone number.

# Instrumentation

## Declination Zone Map

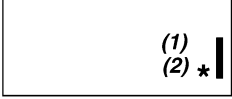

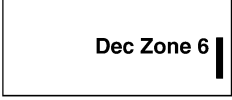



0487229

Step	Procedure	Displayed Message
1	Select Quadrant 2 (lower right) on the display by turning the display control knob either clockwise or counterclockwise.	 <p>(1) (2) *  </p> <p>3817049</p>
2	Select the Compass Declination message by pressing and releasing the display control knob until this message appears.	 <p>Compass Declination *  </p> <p>3817053</p>
3	Press and hold the display control knob until any Declination Zone number (0 – 10) is displayed.	 <p>Dec Zone 2  </p> <p>3817054</p>
4	<p>Turn the display control knob clockwise or counterclockwise until the desired Declination Zone number is displayed. Refer to Declination Zone Map to determine the proper number for the current geographic location.</p> <p><b>NOTE: If no Declination Zone number is selected within 15 seconds, the display will return to the Compass Declination message.</b></p> <p><b>NOTE: If the compass is being calibrated / recalibrated, the Declination Zone must be set to the Zone number for the location where the compass calibration / recalibration is being performed regardless of the location where the vehicle will eventually operate.</b></p>	 <p>Dec Zone 6  </p> <p>3817055</p>
5	Press and <b>HOLD</b> the display control knob until the Compass Declination message appears (this indicates that the new Declination Zone number has been programmed into the compass).	 <p>Compass Declination *  </p> <p>3817053</p>

## Instrumentation

### Compass Directional Calibration Procedure

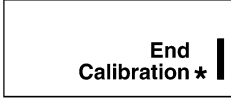
To begin the Compass Directional Calibration Procedure, stop the vehicle in an area large enough to permit driving in complete circles and perform the following steps:

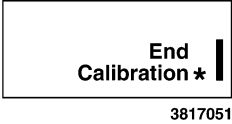
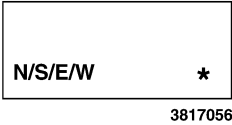

Step	Procedure	Displayed Message
1	Select Quadrant 2 (lower right) on the instrument panel gauge cluster display by turning the display control knob either clockwise or counterclockwise.	 <p>3817049</p>
2	Select the Calibrate Compass message by pressing and releasing the display control knob until this message appears.	 <p>3817050</p>
3	<p>Press and hold the display control knob until the End Calibration command is displayed.</p> <p><b>NOTE: IF the End Calibration command will not show up, turn OFF the vehicle, restart it, and return to Step 1.</b></p> <p><b>NOTE: The following steps (4 through 6) must be completed within 3 minutes to lock-in the new calibration. Do not press the display control knob or turn the key OFF until these steps are completed or the calibration process will be cancelled.</b></p>	 <p>3817051</p>
4	Immediately following the End Calibration command being displayed, drive the vehicle in 3 complete circles (during this time the compass display will go blank or have dashed lines present).	 <p>3817052</p>

<p>5</p>	<p>Stop the vehicle and wait shortly. The End Calibration message should reappear on the display.</p>	
<p>6</p>	<p>Push and <b>HOLD</b> the display control knob until the End Calibration command disappears. The calibration should now be complete. <b>IMPORTANT!: Just pressing and failing to hold the display control knob inward until the End Calibration command disappears will cancel the calibration procedure and you must start over at Step 1.</b></p>	
<p>7</p>	<p>Test the compass calibration. Turn the vehicle ignition key OFF and then restart the vehicle. Wait 10 seconds for the compass to complete its self test. Drive the vehicle in a circle and note the compass readings:</p> <ul style="list-style-type: none"> <li>• If the lower left quadrant of the Instrument Panel Gauge Cluster Display shows the correct compass / vehicle heading, the compass calibration is now complete.</li> <li>• If the compass readings are incorrect, inspect for correct Declination Zone number, turn OFF the vehicle, restart the vehicle, wait 10 seconds, and perform another circle while periodically noting the compass readings.</li> <li>• If readings are still incorrect, restart the compass calibration procedure.</li> </ul>	

# Instrumentation

## User Switches

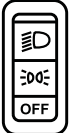
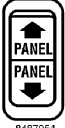
The Instrument Panel Gauge cluster provides locations for six user defined switches. The following table describes the functional details of the standard switch configurations.

Item No.	Item	Description	Switch Indicator Status
<b>Left Side Optional Push Button Switches</b>			
49	Configured by customer request		
50	Configured by customer request		
51	 0000058012	<b>Headlight / Park Lamp Switch</b>	Go to Lights section
52	 8487054	<b>Instrument Panel Gauge Cluster Dimmer Switch.</b>	Go to Lights section
<b>Right Side Optional Switches / Indicators</b>			
53	 8487056	<b>Cab Dome Light Switch.</b> Used to turn cab dome light on and off and make it possible to activate / deactivate the dome light coming on when opening the doors.	
54	Configured by customer request		

**Instrument Panel Gauge Audible Alarms**



**To prevent property damage, personal injury, and / or death, when an alarm sounds, stop normal vehicle operation and determine the source of the alarm condition.**

Audible alarms are used in addition to warning indicators and gauges. An audible alarm sounds when a problem exists with one of the vehicle functions. Audible alarms sound when one of the gauges indicates an abnormal condition, or when there is a problem with one of the vehicle systems. When an audible alarm is heard, have the system inspected immediately, and do not operate the bus until the bus is serviced.

**Audible Alarms**

<b>Alarm Condition</b>	<b>Audible Alarm Pattern</b>	<b>Additional Comments</b>
<b>Fuel Level Gauge</b> low (only alarms on each key switch turn-on)	5 BEEPS	Gauge warning indicator illuminates.
<b>Voltmeter Gauge</b> out of range reading	5 BEEPS	Gauge warning indicator illuminates.
<b>Engine Oil Pressure Gauge</b> out of range reading	5 BEEPS	Gauge warning indicator illuminates.
<b>Engine Coolant Temperature Gauge</b> out of range reading	5 BEEPS	Gauge warning indicator illuminates.
<b>Transmission Oil Temperature Gauge</b> out of range reading	5 BEEPS	Gauge warning indicator illuminates.
<b>Diesel Exhaust Fluid (DEF)</b> level low	1 BEEP	Instrument panel gauge cluster warning indicator illuminates.
<b>Selective Catalytic Reduction (SCR)</b> system fault	1 BEEP	Instrument panel gauge cluster warning indicator illuminates.
<b>Exhaust Diesel Particulate Filter Regeneration</b>	CONTINUOUS TONE	Critical soot level.
<b>Auxiliary Air Pressure Gauge</b> out of range reading	5 BEEPS	Gauge warning indicator illuminates.

## Instrumentation

### Audible Alarms (cont.)

Alarm Condition	Audible Alarm Pattern	Additional Comments
Gauge sensor faults	5 BEEPS	Gauge pointer goes to 6 o'clock position and gauge warning indicator illuminates.
RED Stop Lamp illuminates	REPEATING SINGLE BEEP	Gauge warning indicator illuminates.
Brake Pressure Indicator illuminates	REPEATING SINGLE BEEP	Gauge warning indicator illuminates.
Electrical System Controller fault	10 BEEPS	CHECK ELEC SYS warning indicator illuminates.
Emergency Exit Alarm	CONTINUOUS BUZZER	Check for an unlatched emergency exit.
Post Trip Inspection	REPEATED SINGLE BEEP, LIGHTS FLASHING THEN HORN HONKING	Complete the Post Trip Inspection.
Turn Signal Alarm	CONTINUOUS TONE	Alarm sounds if either turn signal is on for more than one mile.  Will not activate when hazard flashers are on.
Low Coolant Alarm	REPEATING SINGLE BEEP	Gauge warning indicator illuminates.
Seat Belt Reminder With Seat Belt Monitoring	REPEATING SINGLE BEEP	Gauge warning indicator illuminates.



## SECTION 4 — DRIVER CONTROLS

### Windshield Wiper / Washer System

#### Wiper Blade Speed

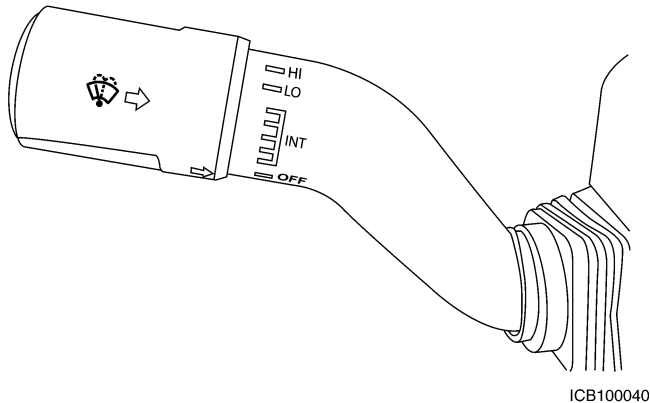

The windshield wiper / washer switch is located on the left side of the steering column.

Rotate the windshield wiper control to the desired interval, low or high speed position.

The bars are for intermittent wipers. When the wiper control is in the intermittent position, rotate the control upward for faster intervals, and downward for slower intervals.

#### Windshield Wiper Speed Control

This optional feature forces wipers to slowest intermittent speed when parking brake is set and wipers are left on for a predetermined time.

#### Windshield Washer



**To prevent property damage, personal injury, and / or death, do not use the washers in freezing weather without first warming the windshield with the defrosters; otherwise, the washer solution may freeze on the windshield and obscure your vision, which could cause an accident.**



**To prevent property damage, personal injury, and / or death, do not use radiator coolant or antifreeze in the windshield washer reservoir. Radiator coolant in the washer reservoir can severely reduce visibility when sprayed on the windshield, which could cause an accident.**

Push the control on the end of the stalk inward to activate the washer function. Push and hold for a longer wash cycle. Using the windshield washer function activates the wipers. The wipers automatically cycle to clear the windshield, and also stop automatically after a five second cycle.

### Turn Signal

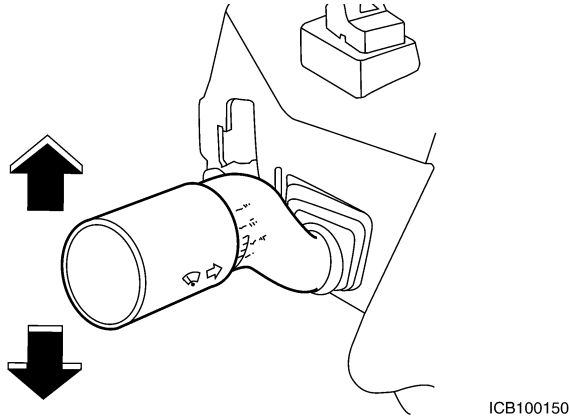

The turn signal switch is located on the left side of the steering column and is part of the multi-function switch. Move the lever up or down to signal the turning direction. After the turn has been completed, the turn signal automatically cancels.

For additional information about the Turn Signal Multi-Function Switch refer to the Lights section.

### Steering Wheel and Column

#### Steering Wheel Controls (BE Optional and CE Standard)

**NOTE:** The location for the entry door and warning flasher switches is the steering wheel, and the right console switch panel. The standard location for these switches in the BE bus is the left switch panel.

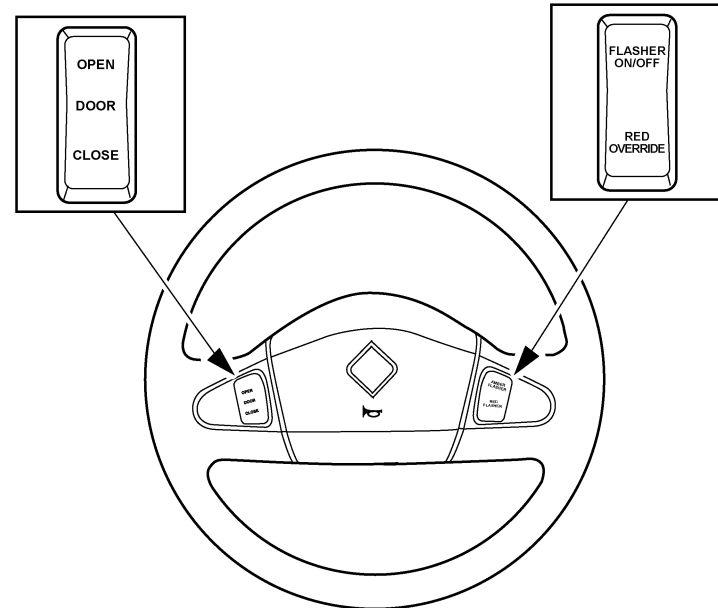

OPEN / CLOSE DOOR button is located on the steering wheel in the left button position.

FLASHERS ON / OFF and RED OVERRIDE button is located on the steering wheel in the right button position.

For the uses of these buttons see the **Passenger Control** section.

## Steering Wheel Controls (BE Standard and CE Optional)

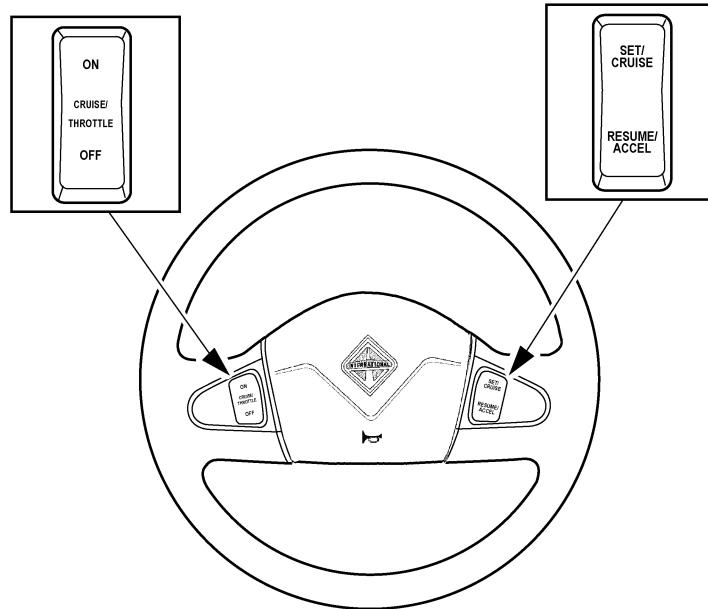

For the correct use of the cruise control switches in this location, refer to the cruise control procedure later in this section.

## Horn

The horn is a standard electric automotive type and is located in the center of the steering wheel. Push down the horn button to operate it.

## Adjustable Tilt Steering Column



To prevent property damage, personal injury, and / or death, do not adjust the steering column while the vehicle is moving. It could suddenly or unexpectedly move, causing the driver to lose control of vehicle.



To prevent property / vehicle and / or engine component damage, do not lubricate the tilt mechanism.

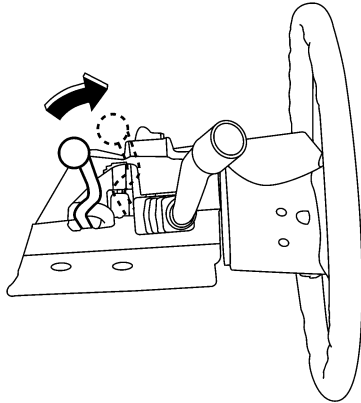

ICB100042

The optional adjustable tilt steering column allows you to pull the tilt steering control toward you and move the steering wheel up or down. Hold the control while adjusting the wheel to the desired position. Release the tilt steering control to lock the column in position.

## Left Console Switch Panel

### Rocker Switches and Their Functions

**NOTE:** Due to differences in state and local requirements and customer preferences, the location and arrangements of the controls and switches on the console switch panels may be different than illustrated. Some switch positions may be empty, while other rows may have only one switch. Switches are installed in the same location unless precluded by state regulations. Before reading this section of the manual, sit in driver's seat and become familiar with the location of the controls and switches in this bus.

**NOTE:** Your bus may not be equipped with all switches listed.

The left console switch panel contains the controls for bus heaters and defrosters, destination sign, and other standard and optional bus body controls.

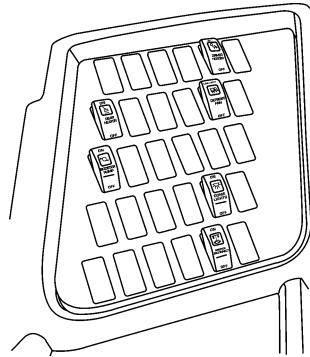

ICB100043

**DRIVER HEATER / DEFROST:**  
Turns heater / defrost blower motor to HI / LO / OFF.

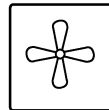

**DRIVER HEATER DEFROST**  
3813093

**REAR HEATER:** Turns heater blower HI / LO / OFF.

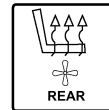

**REAR HEATER**  
ICB900002

**BOOSTER PUMP:** Turns ON / OFF coolant pump in heating system.

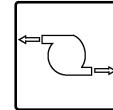

**BOOSTER PUMP**  
ICB100163

**HEATED MIRROR:** Turns heating element behind outside mirror glass ON / OFF.

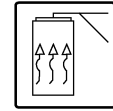

**HEATED MIRROR**  
ICB100165

**LEFT FAN:** Turns HI / LO / OFF driver's defog fan above windshield.

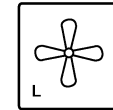

**LEFT FAN**  
ICB900007

**DRIVER DOME:** Turns ON / OFF driver side lights.



**DRIVER DOME**  
ICB100172

**DOVE LIGHTS:** Turns ON / OFF interior side lights.

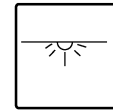

**DOVE LIGHTS**  
ICB100173

## Driver Controls

---

NOISE SUPP: Disconnects power to all noise generating devices.



**NOISE SUPP**  
3813030

LIFT SWITCH: Turns Wheelchair lift power On or Off.

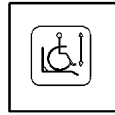

**LIFT**  
3813031

MIDSHIP HEATER: Turns heater blower motor to HI / LO / OFF.



**MIDSHIP HEATER**  
ICB900003

STEPWELL HEATER: Turns the Stepwell Heater ON / OFF.

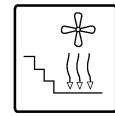

**STEPWELL HEATER**  
ICB900011

POWER VENT: Turns ON / OFF power to exhaust vent.

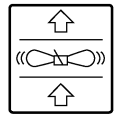

**POWER VENT**  
ICB100164

STOP ARM HEATER: Turns ON / OFF stop arm heater.

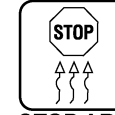

**STOP ARM HEATER**  
ICB100162

HEATED WIPER BLADE: Turns Heated Wiper Blade ON / OFF.

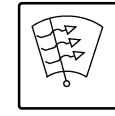

**HTD WIPER BLADE**  
ICB100175

RIGHT FAN: Turns right front windshield defog fan HI / LO / OFF.

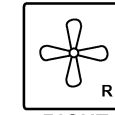

**RIGHT FAN**  
ICB900004

CAMERA: Turns ON / OFF internal (Passenger-viewing) camera.

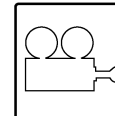

**CAMERA**  
ICB100167

DESTINATION: Turns ON / OFF illumination for destination window.

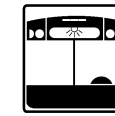

**DSTNATN SIGN**  
ICB900005

STROBE LIGHT: Turns ON / OFF top strobe light.

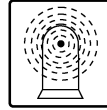

**STROBE LIGHT**

ICB100169

LAST DOME: Turns ON / OFF last dome light.

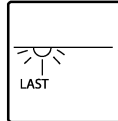

**LAST DOME**

ICB100170

REAR DOME: Turns ON / OFF rear half dome lights.

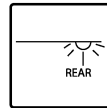

**REAR DOME**

ICB100174

REAR ROW DOME: Turns ON / OFF rear row lights.

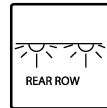

**REAR ROW DOME**

ICB100171

MASTER FLASHER: Turns ON / OFF system power for the warning indicator system.

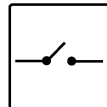

**MASTER FLASHER**

ICB100176

CROSSING GATE (CANCEL): Switch that blocks extension of crossing gate.

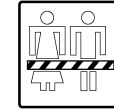

**CROSSING GATE**

ICB100177

STOP ARM STROBE: Turn the optional strobe ON / OFF on the stop arm.



**STOP ARM STROBE**

ICB900008

STOP ARM CANCEL: Momentary switch retracts Stop Arm / Crossing Gate turns on Chime, while RED warning Flashers are on.



**STOP ARM CANCEL**

ICB100179

MASTER DISCONNECT: Controls power to designated body circuits, ignition switch, or rocker switch operations.

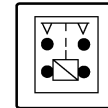

**MASTER DISCONNECT**

ICB100180

AIR HORN: Controls solenoid that turns optional Air Horn On or Off.



0000058013

## Driver Controls

---

### Power Outlet

The optional power outlet is located inside the storage compartment. The power outlet supplies a 12-volt power supply for driver accessories, such as cellular phones and two-way radios.

### Transmission, Parking Brake, and Ignition Switch Panel

Before reading this section of the manual, sit in driver's seat and become familiar with the location of these controls.

The Transmission / Parking Brake / Ignition Switch Panel provides the mounting for the automatic transmission shifter, the knob to engage / disengage the parking brake and the ignition switch.

For instruction on the operation of the components on this panel refer to the "DRIVING" section.

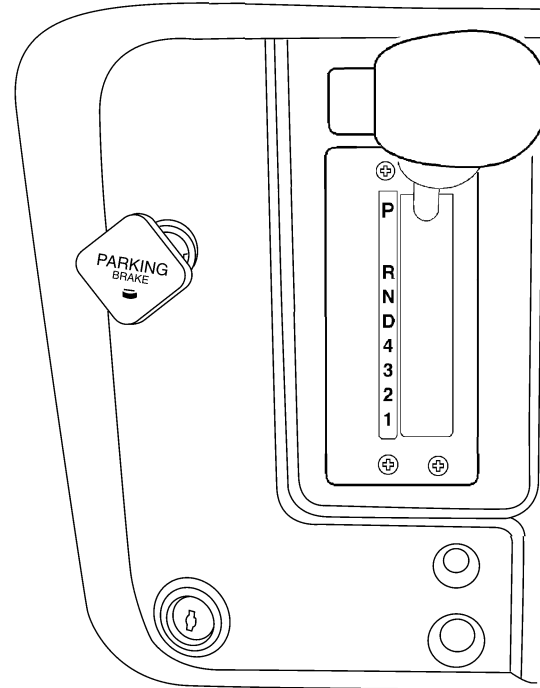



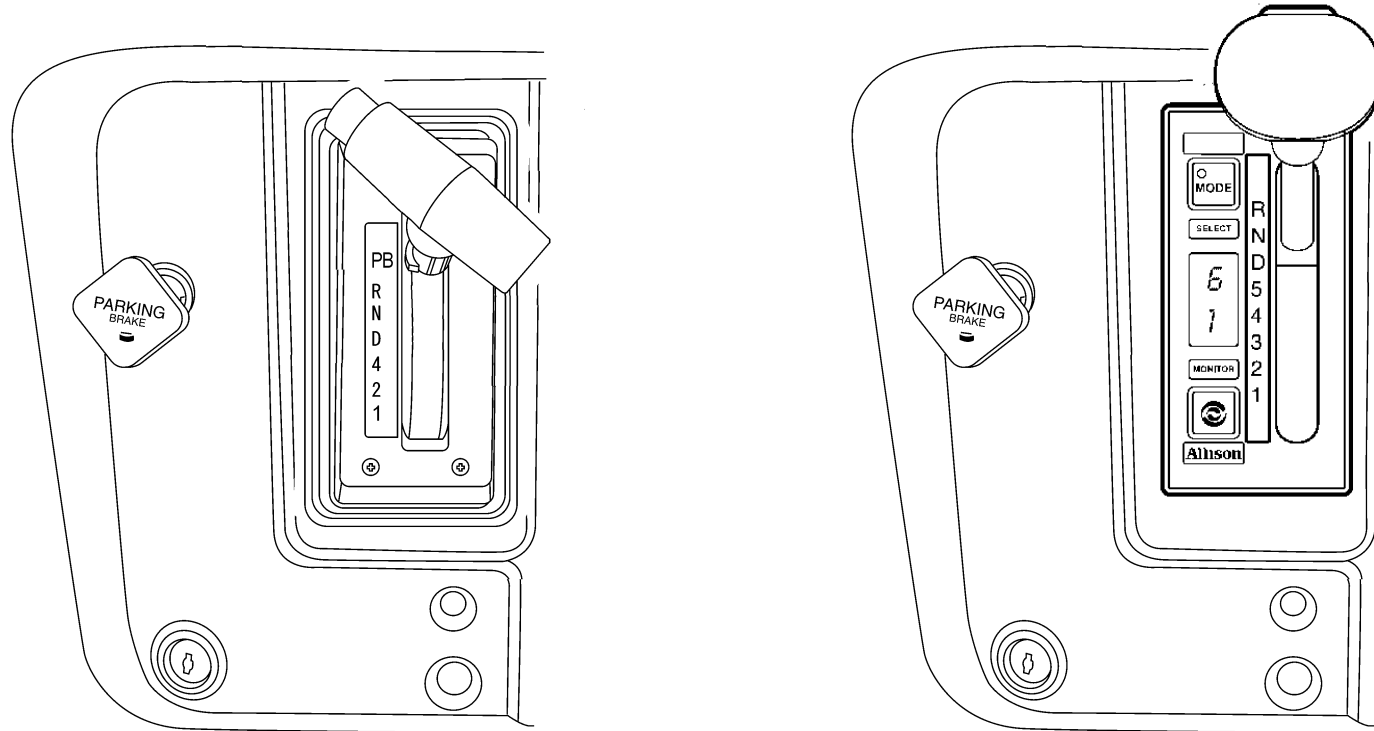

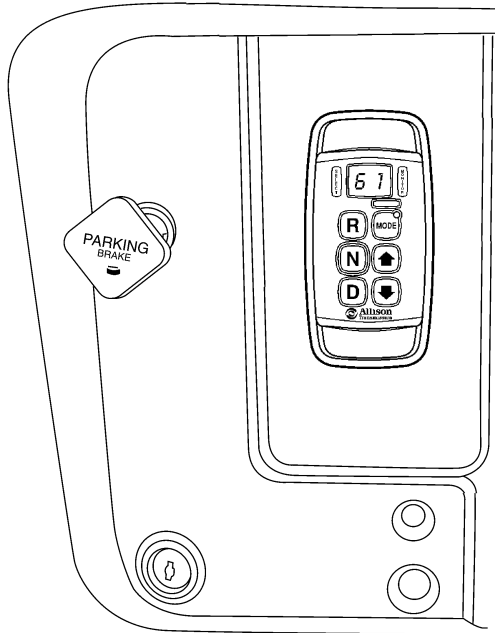

### Right Console Switch Panel

#### Rocker Switches and Their Functions

**NOTE:** Due to differences in state and local requirements, the location and arrangements of the controls and switches on the console switch panels may be different. Some switch positions may be empty, while other rows may have only one switch. Switches are installed in the same location unless precluded by state regulations. Before reading this section of the manual, sit in driver's seat and become familiar with the location of the controls and switches in this bus.

**NOTE:** Your bus may not be equipped with all the switches listed.

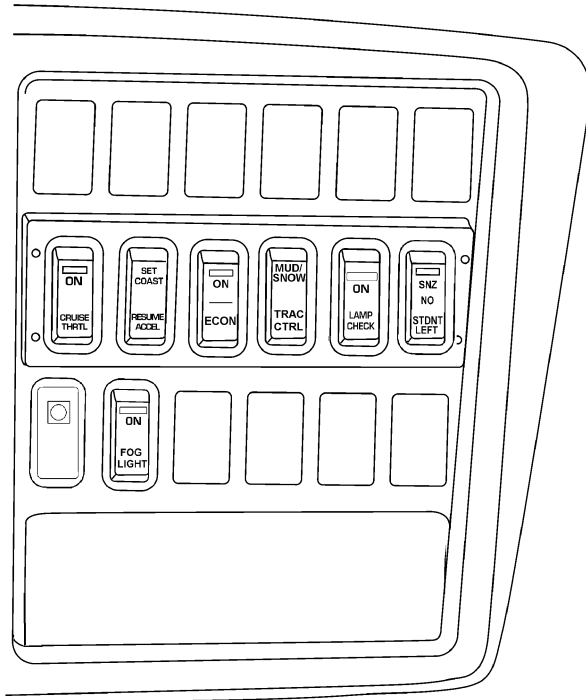

3813096

CRUISE SWITCH: Turns the cruise control system ON and OFF.



CRUISE  
ICB100186

SET / RESUME SWITCH: sets and controls the engine speed.



THROTTLE  
ICB100185

FOG LAMP SWITCH: Turns the fog lamps ON and OFF.

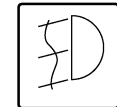

FOG LAMP  
ICB100187

ECON / ON SWITCH: Turns transmission Economy mode ON and OFF.

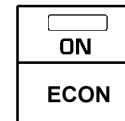

ECON MODE

(Optional) DISAB / TRAC ENAB Switch. Turns Traction Control system ON or OFF (Air Brake chassis).

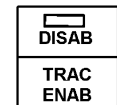

ATC  
3813036

## Driver Controls

---

(Optional) MUD / SNOW) / TRAC CTRL Switch. Controls amount of ATC action of the Traction Control system (Hydraulic Brake chassis).

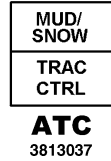

ON / LAMP CHECK. Initiates exterior lamp test during Pre Trip inspection.



SNZ / NO STDNT LEFT. Initiates delay of Post Trip inspection system activation.

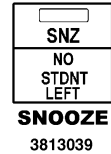

(Optional) Lift Door Indicator. Green indicator flashes to indicate that Lift door is opened.

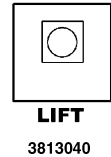

ENG BRAKE – ON / OFF

Turns engine compression brake ON / OFF.



ENG BRAKE 1 / 2 / 3

A three position switch that selects the amount of engine braking (1 = Low, 2 = Medium, 3 = High)



EXH BRAKE – ON / OFF

Turns engine exhaust brake ON or OFF.



PEDAL ADJ – FWD / BACK

Allows forward / upward and back / downward repositioning of power-adjustable pedals when key is in the ON position, the park brake is set, and the transmission is in neutral or park.



## Cruise Control

### Operation



**To prevent property damage, personal injury, and / or death, do not use the cruise control system when unpredictable driving conditions are present. Such conditions include heavy traffic and / or roads that are winding, icy, snow covered, slippery, wet, or with a loose surface. These conditions may cause wheel slippage and loss of vehicle control.**

**NOTE:** The right console switch panel is the standard location for the cruise control switches. These switches may be located on the steering wheel as an available option, moving the entry door controls and pupil warning indicator to the right console switch panel.

The electronic engine vehicle speed controls are activated by the switches located on the console switch panel.

The left ON / OFF switch turns the control feature on or off. The right switch (SET / COAST — RESUME / ACCEL) sets and controls the engine speed.

1. Press the ON position on the ON / OFF rocker switch to activate the cruise control feature.
2. Press the SET position on the rocker switch after reaching a speed of at least 56 km/h (35 mph) to set the cruise speed.

3. Push and hold the RESUME / ACCEL to increase your set speed, or the SET / COAST to decrease your set speed.
4. A slight tap on the brake pedal deactivates the cruise. To return to this speed, press the RESUME / ACCEL position switch.
5. Push the OFF position on the switch to cancel the previous speed setting. The previous speed setting is also cancelled when the vehicle is turned off.

## Mirror Adjustment



**To prevent property damage, personal injury, and / or death, use patience and always check the overall field of vision when unloading, as some children could be outside the field of vision. Do not move your bus until you have confirmed the location of every child and confirmed that they are clear.**



**To prevent property damage, personal injury, and / or death, mirrors are not a substitute for exercising care in operating the vehicle. Mirrors must be properly adjusted for each driver and the driver must be aware of the limitations on the viewing area that exists even when the mirrors are properly used.**



To prevent property damage, personal injury, and / or death, only use the crossview mirrors to view pedestrians while the bus is stopped. Images in such mirrors do not accurately show other vehicle locations.



To prevent property damage, personal injury, and / or death, check to see that area behind vehicle is clear of people, animals, and objects before backing up. Use a spotter whenever possible and always keep that person in sight. If so desired, backup alarms are available through your IC Bus, LLC dealer. However, they are never a substitute for the above procedures.

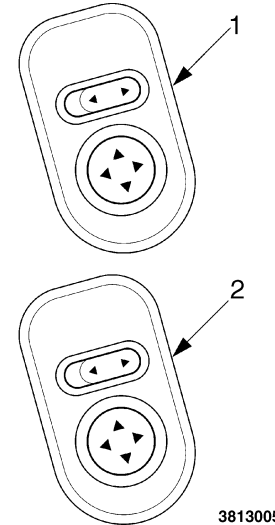

1. Left / Right Side Flat Mirror Adjustment Switch
2. Left / Right Side Convex Mirror Adjustment Switch

The optional mirror adjustment controls are located on the left hand console control panel. The switches with the left and right directional arrows control which side will be adjusted. For left side adjustment make sure the switch is in the left position. For right side mirror adjustment make sure the switch is in the right position.

Before driving the bus, check the mirror adjustment. The mirrors enhance visibility and assist safe vehicle operation. Make sure you can see the entire front of the bus using the cross view mirrors. Use the rear view mirrors to see both sides of the bus,

and at least four bus lengths behind the bus. Use the following steps to adjust the mirrors before you operate the bus.

1. Adjust the driver's seat to the desired position, and observe the view through all outside mirrors to enhance visibility in all directions
2. Look through the right flat driving mirror and make sure that the top of the side windows are visible in the upper edge of the mirror, and that the right side of the bus body is visible in the inside edge of the right flat mirror.
3. Look through the right convex driving mirror and make sure that the view in the top of the convex mirror overlaps the view covered by the right hand flat driving mirror, and that the right side of the bus body is visible in the inside edge of the right hand convex mirror.
4. Look through the left flat driving mirror and the left convex driving mirror and observe that the views are the same as described for the right mirrors. Refer to Steps 2 and 3.
5. Look through and adjust the cross view mirrors to make sure that there is complete visibility around both sides and the front of the bus





## SECTION 5 — LIGHTS

### Headlight Switch and Panel Lighting Control

#### Headlight Switch

These switches are part of the Instrument Panel Gauge Cluster and located below the Instrument Gauges.

The headlights, parking, marker and tail lights are controlled by the three-position PARK / HEADLIGHT rocker switch. This switch functions even when ignition key is turned off.

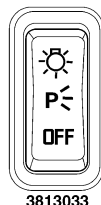

- Place the switch in the top position to turn ON the headlights, parking, marker and tail lights. The Instrument Panel Gauge Cluster illuminates when the park or headlights are turned ON.
- Place the switch in the middle position to turn ON the parking lights, marker lights and taillights.
- Place the switch in the lower position to turn OFF the lights.

**Headlight Warning Buzzer Feature:** This optional buzzer sounds when headlight switch is On and ignition switch is in the Off position.

**Daytime Running Lights Feature:** This optional feature provides for vehicle headlights to be turned on when engine is running and headlight switch is in Off position.

**Optional Headlight Feature (08WPY):** Provides for headlights, tail lights, park / marker lights, and Instrument Panel Gauge Cluster lights to function with ignition switch On and headlight switch Off.

**Optional Headlight Feature (08WRU):** Provides for headlights, tail lights, park / marker lights, and Instrument Panel Gauge Cluster lights to function when the engine is running and headlight switch Off.

# Lights

---

## Automatic Headlights

The optional automatic headlights feature automatically turns on headlights at low ambient light levels. This feature can be overridden, however, by pressing the push button switch in the lower left switch pack in the Instrument Panel Gauge Cluster.



## Panel Lighting Control

The Panel rocker switch controls the panel lighting brightness. Press the upper portion of the rocker switch to increase the brightness. Press the lower portion of the rocker switch to dim the brightness.

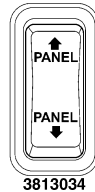

## Interior (Dome) Lights

For control of inside lights, see the Driver Controls section.

## Hazard Warning Light Switch

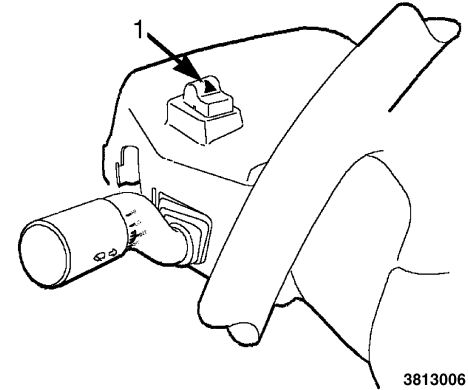

### 1. Hazard Warning Light Switch

Use the hazard warning light switch in an emergency to warn traffic of vehicle breakdown, approaching danger, the vehicle is in tow, or is operating at a reduced speed. The hazard warning lights can be operated with the ignition in any key switch position.

Press the button to activate all hazard flashers simultaneously.

Press the button again to turn the flashers off.

## Turn Signal Switch

The turn signal switch is mounted on the left side of the steering column below the steering wheel. The green directional indicator lights which are activated by the turn signal switch, are located on the instrument panel.

**Signaling for a Turn**

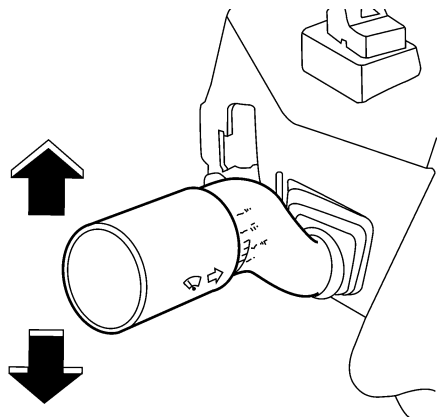

ICB100150

Move the turn signal lever up or down to the full turn position which is past the point of resistance. The turn signal automatically cancels if the steering wheel is turned through a large enough degree.

**Lane Change**

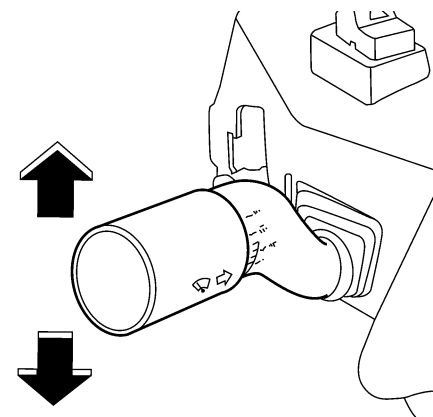

ICB100150

Some switches include a lane change feature which allows you to signal your intention to change lanes without locking the switch into the full turn position. Move the turn signal lever, up or down, to the point where resistance to movement is felt. The turn signal lever returns to the off position when released.

# Lights

---

## HI / LO Beam

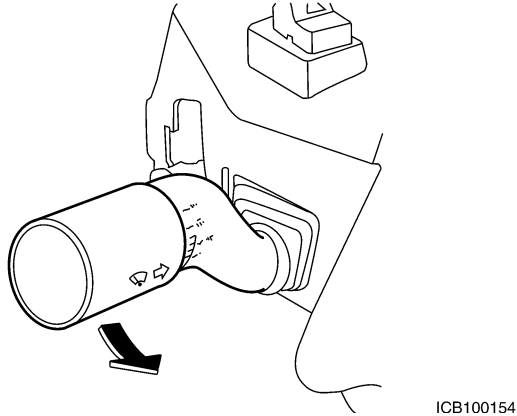

Pull the turn signal lever past the click position, the lights switch to high-beam position. Pull again to return to low-beam.

## Strobe Light

The optional strobe light comes on automatically unless operated by a separate switch. Check your state regulations on strobe light use.

## Exterior Lamp Check

### Switch Location

The switch to activate and deactivate the exterior lamp check system is one of the Right User switches located below the Instrument Panel Gauge Cluster.

### Function

The exterior lamp check is a feature that allows the driver to conduct the exterior lamp check by themselves. The exterior lamp check is included in the pretrip inspection section of this manual. While the system is active, the driver can exit the bus and visually inspect all lights on the exterior of the vehicle for proper operation.

## Activation

To activate the exterior lamp check:

- Turn the key to the ON or Accessory ignition position.
- All lights that will be checked must be turned OFF.
- The parking brake must be applied.
- Place the exterior lamp check switch in the ON (up) position. The exterior lamp switch ON indicator will then illuminate green.

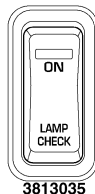

## Deactivation

To deactivate the system, do any one of the following:

- Press the exterior lamp switch to the OFF (down) position.
- Move the ignition switch to the OFF, or ACC position.
- Manually turn on lamps being checked with this feature.
- Release the parking brake.

When the exterior lamp check system is deactivated the green indicator on the switch will turn off.



## SECTION 6 — PASSENGER CONTROL

### Door Opening / Closing

#### Opening / Closing



To prevent property damage, personal injury, and / or death, make sure that each child, and all of their clothing, backpacks, bookbags and other belongings are clear of the vehicle before the door is closed and the bus operated. Consult with local and state authorities for specific procedures that may apply for children entering or exiting buses.

**NOTE:** Due to various state and local requirements, the location of the entrance door Open / Close switches shown may be different than your vehicle.

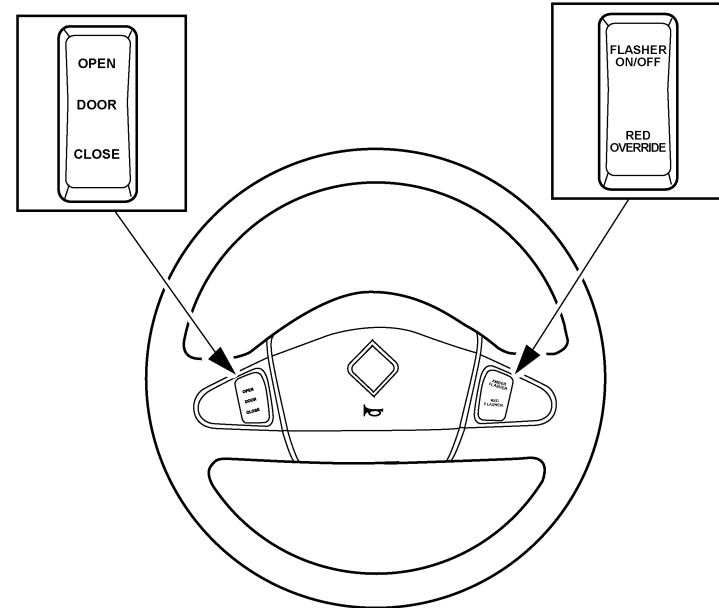

ICB100056

The entrance door Open / Close button is located on the steering wheel in the left button position.

Press the top of the button to open the entrance door.

Press the bottom of the button to close the entrance door.

# Passenger Control

---

## Two-Position Door Switch

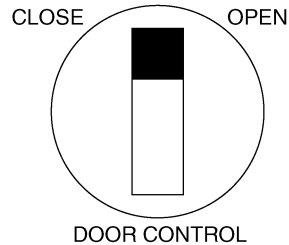

ICB900012

The optional two position door switch is located on the left console switch panel.

With the ignition in the accessory or ignition position, the entrance door can be opened by moving the switch to the OPEN position.

With the ignition in the accessory or ignition position, the entrance door can be closed by moving the switch to the CLOSE position.

## Three-Position Door Switch

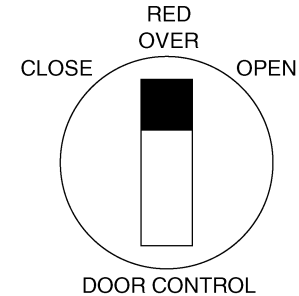

ICB900013

The optional three position door switch is located on the left or right console switch panel.

With the ignition in the accessory or ignition position, the entrance door can be opened by moving the switch to the OPEN position.

With the ignition in the accessory or ignition position, the entrance door can be closed by moving the switch to the CLOSE position.

Moving the switch to the RED OVER position will start the red flashers (assuming the master flasher switch is ON) but will not open or close the entrance door.



## Opening the Entrance Door

### Opening the Entrance Door Manually



To prevent property damage, personal injury, and / or death; For outward opening doors, when the door Manual / Automatic switch is in the manual position, do not allow anyone to lean against the entrance doors, as they will open, allowing a person to fall out of the bus. The manual position is only to be used in Emergency or Service Conditions.

### Electric-Actuated Door

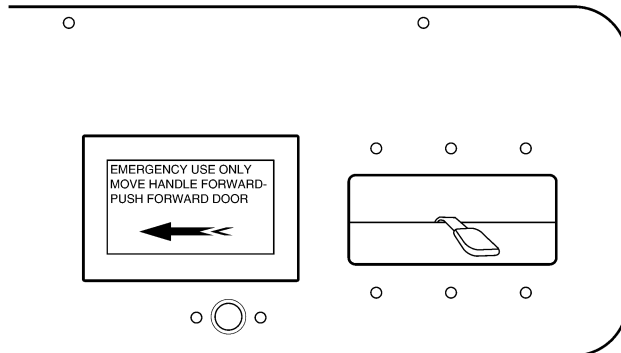

ICB100508

The emergency release for the electrically actuated door is located behind the access panel over the entrance door. To release the electrically actuated door, grasp the handle and move forward (left).

### Air-Actuated Door

The emergency release for the air actuated door is located on the right side of the instrument panel. To release the air actuated door, move the toggle switch from NORMAL to EMERGENCY.

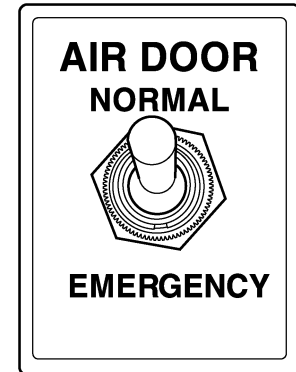

ICB100158

## Traffic Warning System

The Traffic Warning system alerts both oncoming and following drivers when the bus is preparing for safety stops, such as railroad crossing stops, or when loading and unloading passengers. The system consists of an eight-lamp red and amber warning indicator system and an optional electronic safety messages sign. Both of these systems will be described below.

## Passenger Control

### Electronic Safety Messages

The electronic messaging system is an electronic rear facing LED sign that provides two distinct safety messages to alert drivers when the bus is stopping or stopped. When the amber warning lights are activated, the alternating **Caution - Stopping** LED message is flashes.

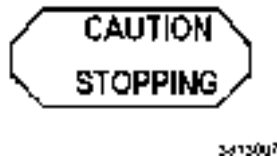

When the red warning lights are activated and the stop arm is deployed, the alternating **Stop - Do Not Pass** LED message flashes. See the description of the Eight-Lamp amber and red warning lights below.



### Eight-Lamp Amber and RED Warning Lights

The eight lamp Amber and Red warning system is made up of four amber (two front and two rear), and four red (two front and two rear) flashing lights, and is part of the warning flasher system.

The amber warning lights alert the public of the intent to stop and load / unload students onto / from the bus. The red warning lights and the stop arm are intended to warn the public that students are boarding or leaving the bus.

The warning indicator control is located on the right side of the steering wheel.

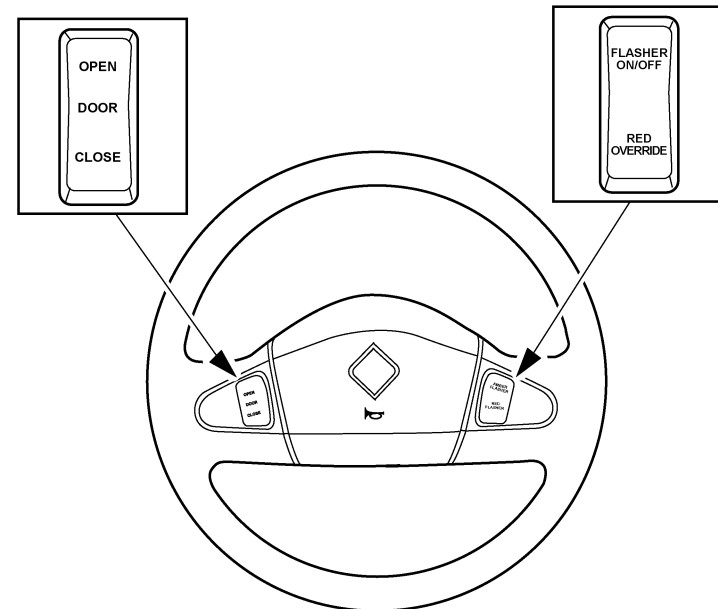

ICB100056

### Optional Rocker Switches



**NOTE:** These switches can be located on the left or right console switch panel.

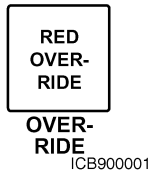

**NOTE:** These rocker switches are an optional alternative to the steering wheel controls. When this option is chosen, the cruise / throttle switches move to the steering wheel location.

### Sequential System

Press the FLASHER ON / OFF button to engage the amber warning lights.

The amber warning lights change automatically to the red warning lights when the entrance door is opened.

The red warning lights will deactivate when the door is closed and the vehicle travels faster than a preset road speed parameter.

(Optional), The red warning lights will deactivate when the door is closed when the bus is not moving.

**NOTE:** If the entrance door is reopened without pressing the FLASHER ON / OFF or the RED OVERRIDE buttons, the red warning lights will not activate.

Press the RED OVERRIDE button twice to turn off the red warning lights while the door is open and the bus is not moving or traveling at a speed lower than the preset road speed parameter with the door closed. ,

### Non-Sequential System

With the master flasher switch in the ON position, press the FLASHER ON / OFF button to engage the amber warning lights. (If the master switch is not turned on, there will be no activation of the lights or stop arm.)

The amber warning lights change automatically to the red warning lights when the entrance door is opened.

The red warning lights will deactivate when the doors are closed.

**NOTE:** If the door is reopened, the red lights will reactivate without pressing the FLASHER ON / OFF or the RED OVERRIDE buttons.

To turn off the red warning lights while the door is open and the bus is not moving, press the RED OVERRIDE switch twice, or turn off the master flasher switch.

## Passenger Control

### WIG WAG Warning System

The optional Wig Wag is a device for flashing the right and left headlights alternately at a preset rate of about 75 times per minute. If the low beams are on, the high beams will alternate and vice versa. If the driving lights are on, the low beams will alternate.

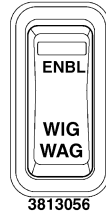

### Flashing Stop Arm

Used to warn the public that students are boarding or leaving the bus

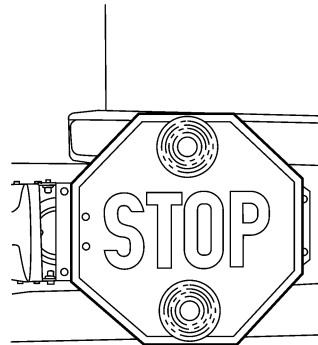

ICB100155

### Crossing Gate

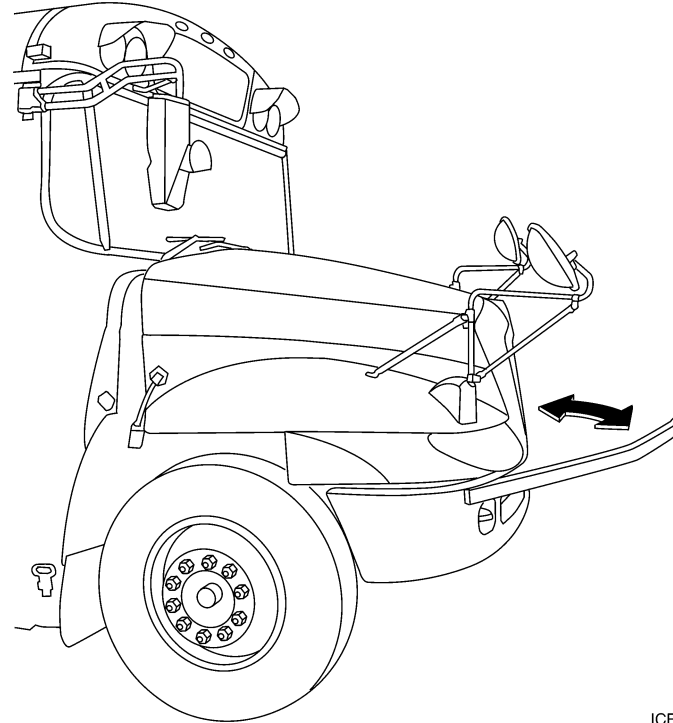

The crossing gate extends when the red warning lights are on to make sure that students do not cross too close to the front of the bus and out of the view of the driver. **NOTE: The illustration is for reference only and may differ from the actual vehicle.**

## Driver Visual Warning Lights and Indicators

The driver's visual warning lights, located in the Instrument Panel Gauge Cluster, indicate the operation of the eight lamp warning system (either amber or red), the wheelchair lift door indicator, and other optional equipment.

Each indicator only comes on when the respective light or switch is activated.

### EXTERIOR LIGHT MONITOR

**(OPTIONAL):** The light monitor is mounted in the overhead console panel.

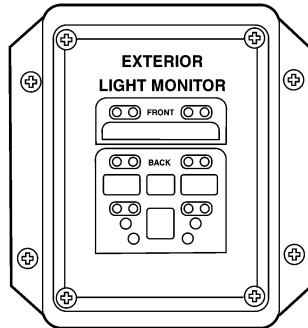

ICB100159

## Audible Warning Buzzer

The audible warning device buzzer is activated when the rear emergency door, roof hatch (if equipped with a buzzer), kickout windows, or side emergency doors are open with the ignition switch in the "ON" or "ACCESSORY" position.

## Post-Trip Inspection (No Student Left Behind)

### System Purpose

It is the driver's responsibility to check for children who may be left on the bus at the end of every trip. The Post Trip Inspection (No Student Left Behind) System is intended to be an aid to the driver to ensure that this responsibility is not inadvertently omitted. The system provides audible and visual alerts when the bus ignition is turned off at the end of a trip.

### System Function

Any time the ignition key is in the RUN position AND the RED flashers have been turned on AND the door is opened (or is already open), the system will be automatically activated. Once the system is activated, it will trigger the vehicle alarm when the ignition is in the OFF position for greater than half a second. At this time, the Instrument Panel Gauge Cluster alarm will begin to beep and the headlights will flash to remind the driver to complete the Post Trip Inspection (No Student Left Behind) deactivation process. **If the deactivation is not completed within 60 seconds, the horn will also begin to honk.**

### System Activation

Normal student pickup / drop off operation of the bus will automatically activate the system. For test purposes, however, this can also be simulated by the following procedure:

1. Start the bus or simply turn the ignition key to the RUN position.
2. Activate the RED flashers.

## Passenger Control

---

3. Open the door (if not already opened).
4. Close the door to turn off the RED flashers.
5. The Post Trip Inspection system will then be triggered (Instrument Panel Gauge Cluster will beep and headlights will flash) when the ignition switch is turned to the OFF position for longer than half a second.

### System Deactivation

To deactivate the Post Trip Inspection (**No Student Left Behind**) system once the system is triggered, the following steps must be performed within 60 seconds (to avoid horn honking):

1. Turn the key to the ACC position and set the parking brake.
2. Close the door (if not already closed).
3. As you proceed to the rear of the bus, check for children that may be still on the bus. When you reach the rear of the bus, lift then lower the rear emergency door lever. If this bus is equipped with the optional post trip inspection RESET BUTTON (located above the last window on the driver's side) press and release this push button.
4. The system is now deactivated, and the Instrument Panel Gauge Cluster beep, headlights and horn should now be off.
5. Move the key to the OFF position. Remove the key if exiting the bus.

### Snooze Mode

This function allows the driver to temporarily disable the No Student Left Behind system activation, and is called the Snooze mode. The purpose is to allow passengers to disembark the vehicle without the No student Left Behind system triggering the vehicle alarm.

This alternate operation allows the driver to turn Off the engine while passengers enter or leave the vehicle.

**Snooze Mode Initiation Procedure.** To initiate the Snooze feature, proceed and observe the following:

1. First, with the engine turned off, place the ignition switch to the ON or ACC position.
2. Press and release the SNZ / NO STDNT LEFT switch to the SNZ position.
3. The switch indicator will turn On, indicating that the Snooze mode is active. This places the (No Student Left Behind) system in Snooze (inhibits triggering of the vehicle alarm) for a predetermined time (default 20 minutes).
4. In the last 60 seconds of the timed Snooze period, the switch indicator will begin to flash, and will continue to flash for the remainder of the time period.
5. After the Snooze period, the switch indicator will turn Off, and the No Student Left Behind system will be re-activated.

**NOTE:** The Snooze function can be turned Off, before the snooze time-out period, by placing the ignition switch to the OFF position.

### BUS-SCAN® 100 System

On the BUS-SCAN® 100 System control box, verify that the system is in the ACTIVE mode and that the Red active LED is illuminated with the ignition switch in the ON position.

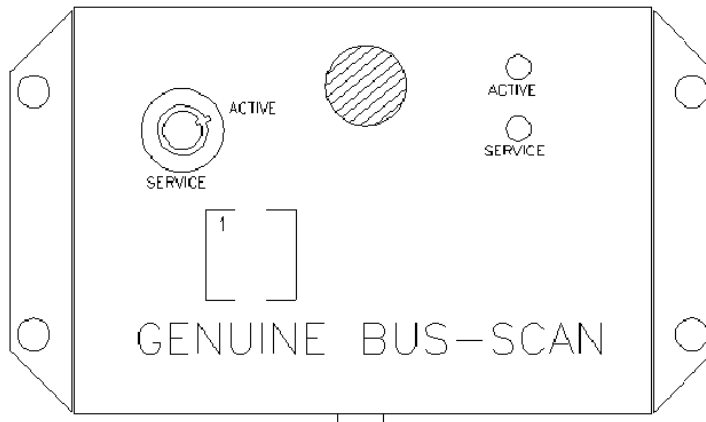
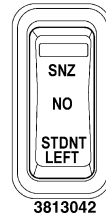

1. Turn ignition OFF.
2. The alarm on the Bus-Scan® control box will sound and the **Right Panel pilot light** will turn on.
3. Walk to rear of bus and press the deactivation switch mounted on the left-hand light bar. If the deactivation switch is not pressed within 60 seconds, the bus horn will begin to honk. The horn can be silenced by turning ignition switch ON, then OFF.

### Unloading Students With Engine Off

The BUS-SCAN® 100 System provides for the safe unloading of students by allowing the driver to have the engine turned OFF and the ignition switch in the ACC position. This will turn the system OFF (indicated by the ACTIVE LED not illuminated). Children can then be helped off the bus without fear of accidental vehicle movement.

### Wheelchair Lift Operation

For operation of the optional Wheelchair Lift (including the Lift Door), refer to the Manufacturer Operator Manual.



**To prevent property / vehicle component damage, personal injury, or death, always set the parking brake when operating the wheelchair lift, or unexpected and sudden vehicle movement may occur.**

#### Wheelchair Lift Interlocks – Extending

Read the following before operating the Wheelchair lift.

The Wheelchair Lift system for these buses are designed with interlocks that require the vehicle to be completely stopped with the transmission out of gear and the Parking Brake applied, before the Wheelchair Lift system can be fully utilized.

Power will not be supplied to the wheelchair lift mechanism unless all of the following steps have been performed (**this is true even with the optional Lift switch in the ON position — See Driver Controls section for the switch description**).

Also, refer to the Brake and Transmission sections for wheelchair lift interlocks.

1. Ensure that the ignition switch is in the ON or ACCESSORY position.
2. Place transmission shift lever in “P” (Park) or” N” (Neutral) position.

3. Apply Parking Brake. The Instrument Panel Gauge Cluster PARK indicator will turn On.

An **(Optional)** feature provides for the Parking Brake to automatically be applied (Auto-Apply) when the transmission shift lever is moved to the “P” (Park) position.

4. Open the Wheelchair Lift door. The Optional green indicator (in Left Control Panel) will flash as long as Lift door is opened.

**NOTE: An Optional Exterior light is provided, which is mounted below the Lift door and activated by opening Lift door. It is used to light up the area while the wheelchair lift is in operation.**

The Wheelchair Lift can now be operated (according to the manufacturer’s Operators Manual instructions). The LIFT DOOR Instrument Panel Gauge Cluster indicator turned On and will remain On as long as the wheelchair lift door is opened.

#### Wheelchair Lift Interlocks–Retracting and Stowing

The vehicle cannot be moved (the transmission cannot be released from “P” (Park) position, or the Parking Brake cannot be released), until the following procedures are completed. Also, refer to the Transmission and Parking Brake sections for their Wheelchair interlocks.

Follow the steps below in the order listed when retracting and stowing the Wheelchair lift:

1. First stow the Wheelchair Lift (according to the manufacturer’s Operators Manual instructions).



2. Then close the Wheelchair lift door (according to the manufacturer's Operators Manual instructions). The LIFT DOOR Instrument Panel Gauge Cluster indicator will then turn Off.

### Wheelchair Lift Alarm

The Instrument Panel Gauge Cluster alarm (a continuous beeping) will be triggered if:

1. The wheelchair lift door is extended **AND**:
2. a. The Parking Brake is not applied (knob is not pulled and released) **OR**  
b. The transmission is not in "N" (Neutral) or "P" (Park).

**NOTE: The alarm will continue to beep until the above conditions are corrected.**

### Emergency Exits

Opening any emergency exit will trigger an alarm to alert the driver when the key is in the on or accessory position.

**NOTE: Either above or below each emergency door and side emergency exit window, a label stating Do Not Block is required by NHTSA no later than April 21, 2004. This label is a warning to the user of the bus not to block the emergency exits with wheelchair, child restraint systems or other items; for example, trash containers.**

Pull up the red lever to unlatch the emergency door. After the door is unlatched, push outward to open. Make sure the printed

operating instructions are present and visible at all times. Inspect every emergency exit every day for proper operation.

### Emergency Door

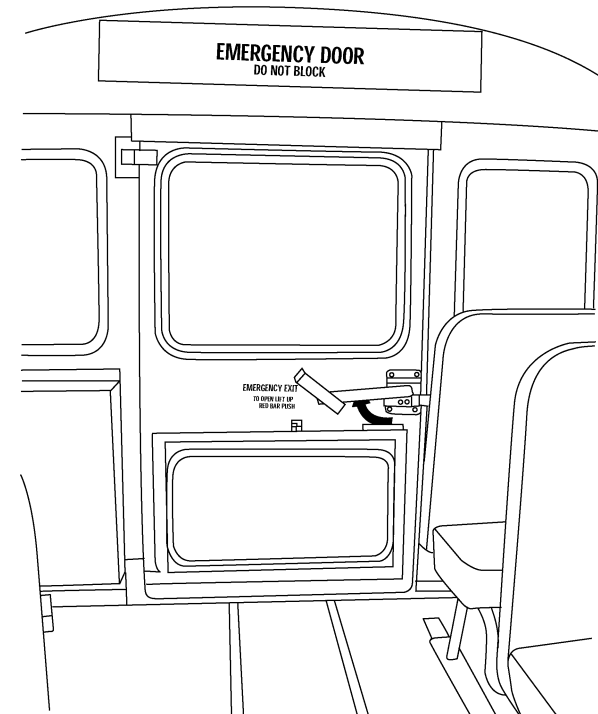

ICB100152

# Passenger Control

---

## Emergency Exit Windows

Two styles of optional emergency exit windows are available for this bus, either horizontal or vertical.

### *Horizontal Emergency Exit Window*

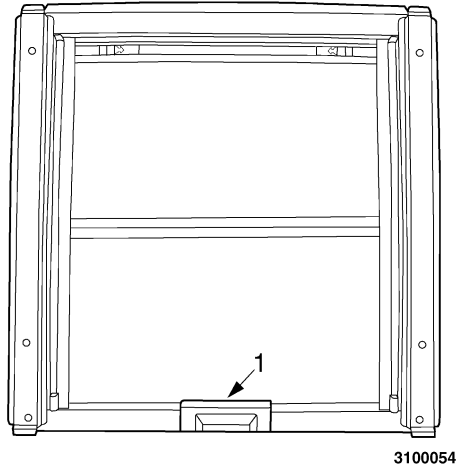

#### 1. Release Handle

Pull up on the release handle to unlatch the Horizontal Emergency Exit Window. After the window is unlatched, push outward on the bottom of the top hinged window to open.

### *Vertical Emergency Exit Window*

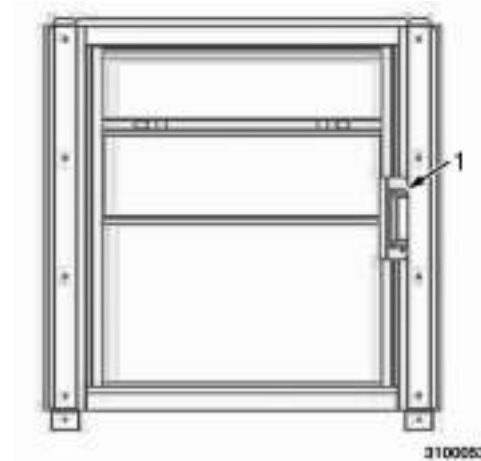

#### 1. Release Handle

Pull up on the release handle to unlatch the Vertical Emergency Exit Window, and push the window outward to open.

**NOTE: Make sure the printed operating instructions are present and visible at all times. Inspect every emergency exit every day for proper operation.**

Roof Vent / Hatch

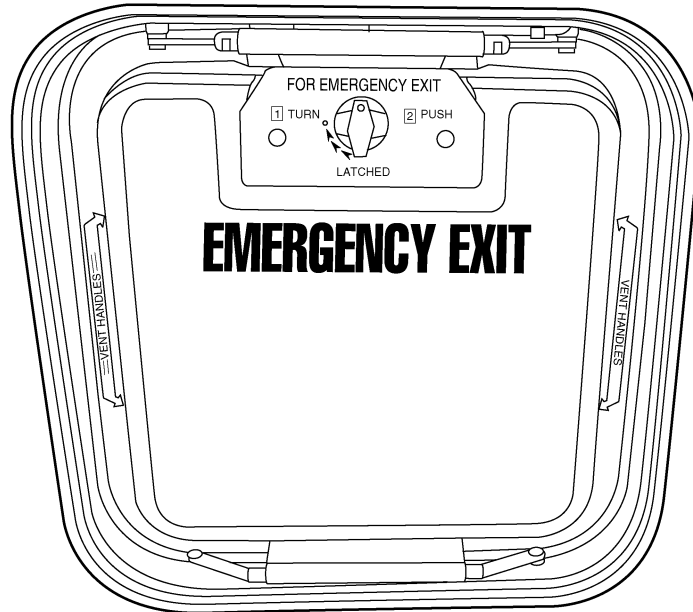

ICB100151

When using the vent, push upward at the locations marked on the hatch.

Open the hatch by turning the red knob to the 2 position, then push upward on the knob. Make sure the printed operating instructions are present and visible at all times. Inspect every

emergency exit for proper operation every day. The emergency hatch type may be different in your bus. If your emergency hatch is different, become completely familiar with its operation before driving the bus.



## SECTION 7 — SEATING AND SAFETY RESTRAINTS

### Driver Seat Adjustment



To prevent property damage, personal injury, and / or death, always use occupant restraint system when vehicle is moving. Any location in the vehicle not equipped with a seat belt, bunk restraint belts, or sleeper berth restraint webbing should not be occupied when the vehicle is being operated.



To prevent property damage, personal injury, and / or death, do not adjust driver's seat while vehicle is moving. The seat could suddenly or unexpectedly move, causing the driver to lose control of vehicle.



To prevent property damage, personal injury, and / or death, use caution and reduce speed when operating this vehicle over rough roads or surfaces as this can cause loss of vehicle control. Properly adjusted seats and seating systems may not compensate completely for severe road conditions. Ensure that head clearance will be maintained during all road conditions, as the seat may move up and decrease the available space.



To prevent property damage, personal injury, and / or death, apply parking brake and place transmission in park (if available), or neutral prior to exiting the driver seat.

**NOTE:** This bus may be equipped with an optional driver seat that may be different than the one described in this manual. If so, refer to the seat manufacturer's manual for proper operation and maintenance.

## Seating and Safety Restraints

### Seat Height Adjustment

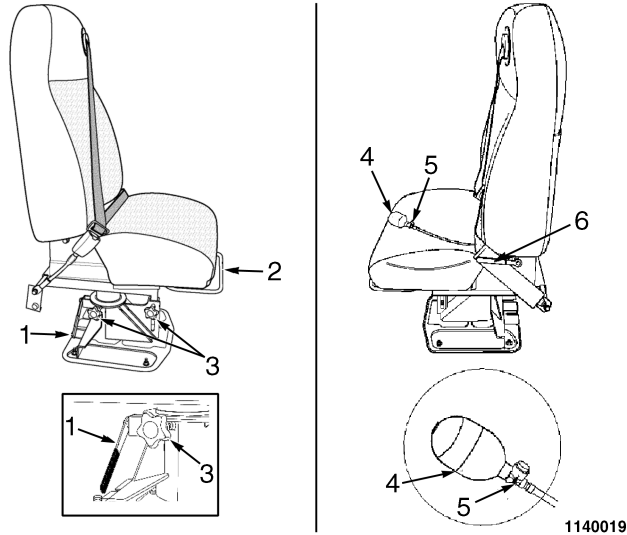

1. Seat Height Lever
2. Forward / Aft adjustment Bar
3. Seat Height Adjustment Lock Knob
4. Lumbar Support Squeeze Bulb
5. Release Valve
6. Seatback Adjustment Lever

There are three possible seat heights available: Top, Middle, and Low. At the top position three adjustment holes are visible, and at the low position none of the holes are visible.

**NOTE: All seat height adjustments must be made WHILE NOT SITTING IN THE SEAT.**

Adjust the seat height as follows:

1. Loosen the Seat Height Adjustment Lock Knob just enough to allow seat height adjustment.
2. While standing to the side of the seat, lift and hold the Seat Height Lever while raising or lowering the seat to the desired height, then release the lever. While adjusting the seat height, the Seat Height Lever may remain in the up position. The location and orientation of the Height Adjustment Lever may vary.
3. When at the desired position, move the seat slightly up or down until the Seat Height Lever snaps to its height engaged (down) position.
4. After the desired seat position is satisfied, tighten the Seat Height Adjustment Lock Knob.

### Forward / Aft Adjustment

Lift and hold the Forward / Aft adjustment Bar to move the seat forward or backward, and release the lever at the desired position.

### Seatback Adjustment

The seatback adjustment lever is located on the left of the seat. Lift and hold the seatback lever while moving the seatback

forward, or rearward, and release the lever at the desired position.

### Lumbar Support Adjustment

Squeeze the Lumbar Support Squeeze Bulb to move the support upward. To move the lumbar support downward, release the air from the Lumbar Support Squeeze Bulb, by turning the release valve counterclockwise.

### Optional Air Suspension Seat

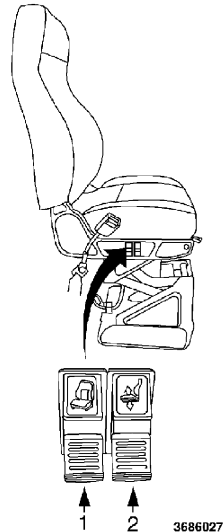

1. Lumbar Adjustment
2. Height Adjustment

### Forward / Aft Adjustment Lever

Move and hold the Forward / Aft Adjustment Lever to the left to move the seat forward or backward.

### Seatback Adjustment Knob

The seatback adjustment knob is located on the left of the seat at the intersection of the seatback and the lower seat cushion. Turn the seatback adjustment knob clockwise to tilt the seatback forward and rotate the knob counterclockwise to tilt the seatback rearward.

### Lumbar Support

Pull the left switch (Lumbar Support Switch) upward or push downward to adjust the lumbar support to your preference.

### Height Adjustment Switch

Lift the Height Adjustment Switch upward to adjust the seat height. While seated, pull the lever up and release when an acceptable height has been achieved. To lower the seat, depress the switch and stop when an acceptable height has been reached.

### Driver Seat Belts



To prevent property damage, personal injury, and / or death, any seat belt in use during an accident must be replaced. When replacement of any part of the seat belt is required, the entire belt must be replaced, both retractor and buckle sides.



To prevent property damage, personal injury, and / or death, properly inspect and maintain seat belts.

Wear your seat belt at all times the vehicle is in motion to avoid personal injury. Before fastening the seat belt, adjust the seat to the desirable driving position. Driver's lap and shoulder (three-point) seat belt with retractor is standard.

### Driver's Adjustable Lap and Shoulder (Three-Point) Belt



To prevent property damage, personal injury, and / or death, position the safety belt height adjusters so that the belt rests across the middle of your shoulder. Failure to adjust the safety belt properly could reduce the effectiveness of the seat belt.

Inspect the entire seat belt assembly for corrosion, wear, fraying or weak spots. Check the retractor, latch, and buckle for proper function, and all seat belt mounting bolts for tightness.

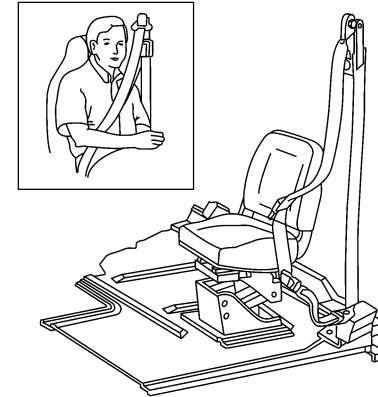

ICB100069

Bring the belt across your hips and chest and insert the latch plate into the buckle until secure to fasten the seat belt. The web is free to slide through the latch plate, allowing the belt tension to equalize across your hips and chest. The retractor is a locking type that allows the webbing to adjust for body movement.



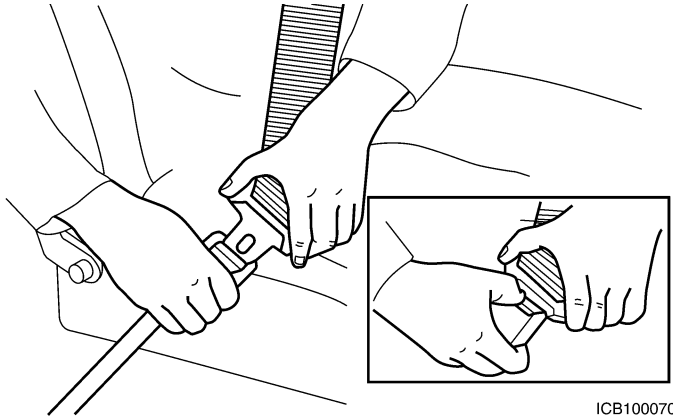

Press the release button to disconnect the seat belt.

### Seat Belt Tether

**NOTE: The majority of the driver seats have nonadjustable tethers. Driver seats with adjustable tethers must follow the Tether Adjuster Procedure.**

### Tether Adjuster Procedure

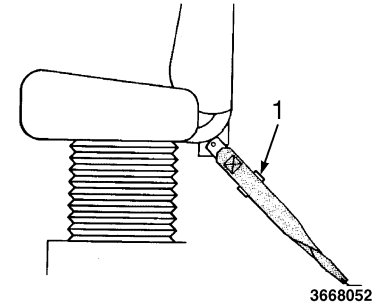

1. Tether Adjuster

**NOTE: The seat belt tether must be checked for proper adjustment prior to vehicle operation.**

1. Adjust the driver seat fore and aft to accommodate driver comfort.
2. After the seat is adjusted, take weight off the seat to allow the seat to rise to its highest point.
3. Pull the webbing through the tether adjuster until there is no slack.

### Adjusting the Length of the Tether

#### Shortening The Tether.

1. Tether Adjuster
2. Wire Loop
3. Nub

To shorten the tether, squeeze the tether adjuster and pull the nub and wire loop to move the webbing away from the tether adjuster (as shown by the arrows).

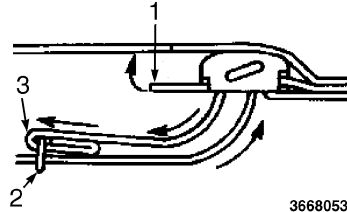

#### Lengthening The Tether.

1. Tether Adjuster
2. Strap
3. Wire Loop

To lengthen the tether, squeeze the tether adjuster and, while firmly holding the strap, use the nub and wire loop to move the webbing toward the adjuster (as shown by the arrows).

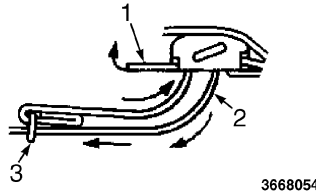

### Care of Seat Belts



To prevent property damage, personal injury, and / or death, do not bleach or re-dye seat belt webbing. Bleaching or re-dyeing may cause a weakening / premature deterioration of the webbing.



To prevent property damage, personal injury, and / or death, use caution when cleaning seat belts. Disinfectant products can contain solvent based chemicals that can adversely affect seat belt components.

#### NOTE:

- Do not use a 70% isopropyl solution as a wash solution.
- Do not use a 70% isopropyl solution wipe on seats that are hot from daytime heat.
- Vapors can accumulate quickly when using a 70% isopropyl solution wipe. Maintain adequate ventilation by opening windows and doors.
- The effectiveness of the 70% isopropyl solution can be diminished when used in high heat conditions due to evaporation.

Clean the belts occasionally with mild soap. Do not use cleaning solvents or abrasives.

A 70% solution of isopropyl alcohol can be used as a disinfectant wipe. A 70% isopropyl solution is readily available from local sources.

### Inspection of Seat Belts

Inspect the buckle and latch plate for positive engagement and effective release. Inspect the webbing for damage or wear. Replace the entire belt if any deficiencies are found.

### Seat Belt Cutter

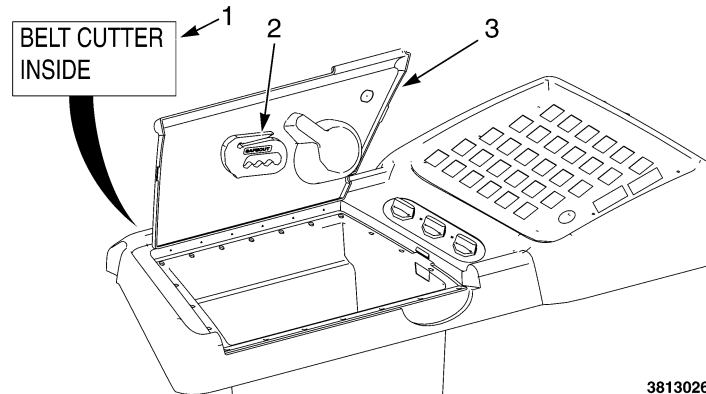

3813026

1. Belt Cutter Label
2. Seat Belt Cutter
3. Lid

If it becomes necessary to cut through a seat belt, the seat belt cutter is located inside of the driver's compartment lid.

**NOTE:** Location of seat belt cutter may vary according to state regulations.

### Passenger Seat Belts

Buses may be equipped with optional passenger seat belts.



To prevent property damage, personal injury, and / or death, properly inspect and maintain seat belts.



To prevent property damage, personal injury, and / or death, any seat belt in use during an accident must be replaced. When replacement of any part of the seat belt is required, the entire belt must be replaced, both retractor and buckle sides.

## Seating and Safety Restraints

### Passenger Two-Point Seat Belt (Lap Belts)

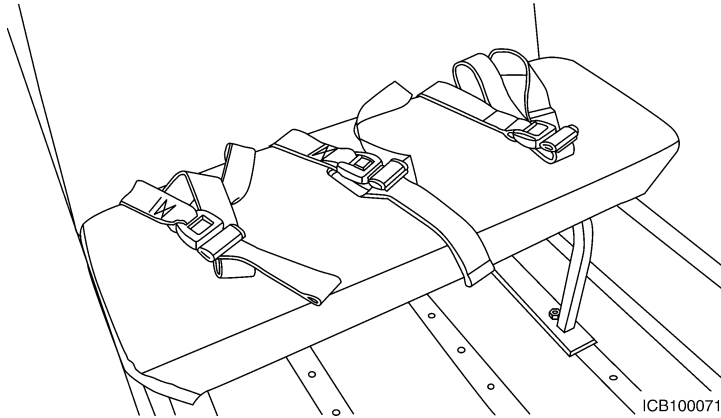

To loosen the belt, slide the latch up the webbing as far as necessary to make the belt go around the passenger's lap. Insert the latch plate into the buckle until secure. To loosen, pull up on the lap belt. Tighten the belt until it is snug by pulling on the loose end of the belt. Push the release button on the buckle to release the seat belt. Position the lap portion of the belt so that the webbing is below the passenger's waste, not over the stomach or abdomen area. The lap portion of the belt must be low and snug over the bony structure of the passenger's hips.

### Passenger Three-Point Seat Belts (Optional)

#### *Buckling Up*

1. The passenger should sit as flat against the seat back as possible to achieve the best possible fit of the lap-shoulder belt on the passenger's upper and lower torso.
2. Pull out the shoulder belt webbing from the upper seat back. Do not let the belt get twisted. (The shoulder belt may lock if pulled across the body too quickly. If this happens, let the belt retract slightly to unlock it. Then pull the belt across you more slowly).
3. Place the lap-shoulder belt over the shoulder and around the passenger's upper body.

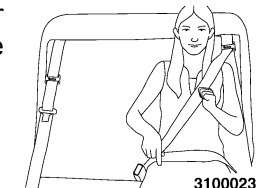
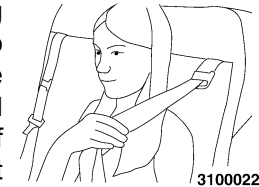
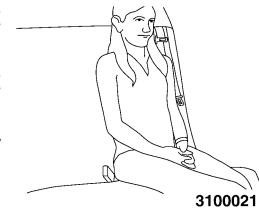

4. Insert the latch plate into the matching seat belt buckle on the lower seat cushion.

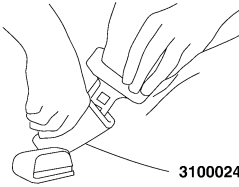

5. Listen for an audible click when the latch plate is fastened. Check that the buckle connection is secure by pulling on the shoulder portion of the lap-shoulder belt.

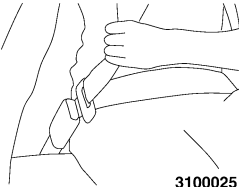

6. Position the lap portion of the belt so that the webbing is below the passenger's waist, not over the stomach or abdomen area. The lap portion of the belt must be low and snug over the bony structure of the passenger's hips.

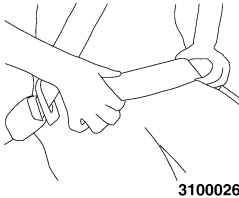

7. Pull up on the shoulder portion of the lap-shoulder belt to tighten the lap portion.  
**THIS STEP IS IMPORTANT AND MUST BE DONE TO ENSURE PROPER FIT OF LAP-SHOULDER BELT TO PASSENGER!**



The shoulder portion of the belt must be snug across the chest and in the center of the passenger's shoulder.

8. Position the shoulder height adjuster at or just above the passenger's shoulder. The shoulder belt should not cross the passenger's face or neck.

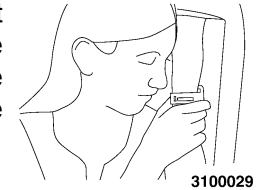

9. Make sure the lap-shoulder belt is snug and lies flat against the passenger. There should be no twisting of the webbing.



### *Unbuckling*

1. Push the RED buckle release button and remove the latch plate from the buckle. The buckle has a release mechanism that separates the latch plate from the buckle.

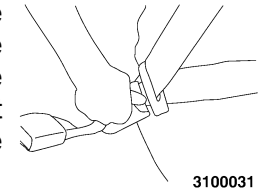

2. Allow the shoulder belt to retract and stow in the upper seat back.
3. As a courtesy to the next passenger, move the shoulder height adjuster up to the highest position.

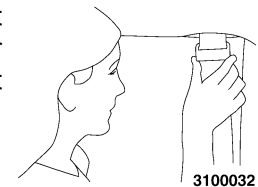

## Seating and Safety Restraints

---

### 39 Inch Flex Seat

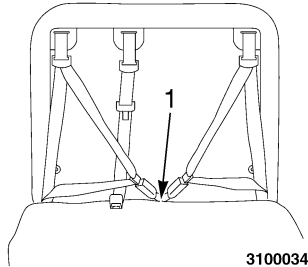

#### 1. Sliding Dual Buckles (Two Seating Position)

**Use for two children:** Slide the sliding dual buckles on right side all the way left to create two seating positions.

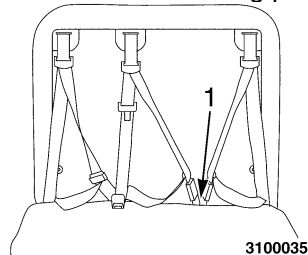

#### 1. Sliding Dual Buckles (Three Seating Position)

**Use for three children:** Slide the sliding dual buckles on right side all the way right to create three seating positions.

### Integrated Child Restraint Seats (Optional)



**WARNING**

To prevent property damage, personal injury, and / or death, observe the following:

- Follow all instructions on the child restraint and in this manual.
- It is important to use an approved rearward facing infant restraint for a full year to allow the neck and spine to develop enough to support the weight of the child's head in the event of a collision.
- Adjust the belts provided with this child restraint snugly around your child.



To prevent property damage, personal injury, and / or death, observe the following:

- A frayed or torn child restraint belt could rip apart in a collision and leave your child with no protection. Inspect the belt system periodically, checking for cuts, frays, or loose parts. Damaged parts must be replaced immediately.
- Do not disassemble or modify the system.
- Child restraint belt systems must be replaced after a collision if they have been damaged (such as a bent buckle or 5-point connector, or torn webbing). Similarly, the child restraint-equipped bench or bucket seat must be replaced after a collision if it is damaged (such as a bent or broken seat frame).

### Indiana Mills and Manufacturing Inc. (IMMI®) Integrated Child Restraint Seats (Optional)



To prevent property damage, personal injury, and / or death, observe the following:

- Used only with children who weigh between 22 and 85 lb (10 and 39 kg), and whose height is 49 in (124 cm) or less, and who are under one year of age.
- Top portion of the seat cushion must be folded under lower portion of seat cushion to form seating surface for child.

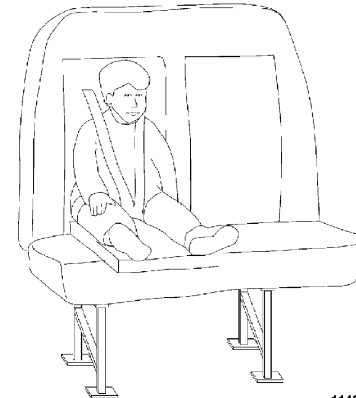

1140018

## Seating and Safety Restraints

---

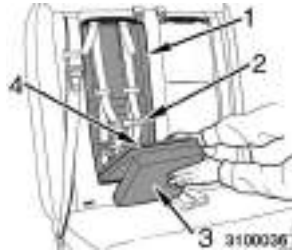

1. Removable Seat Pad
2. Chest Clip
3. Two Piece Seat Cushion
4. Harness Buckle

Activate the restraint system by lowering the two-piece seat cushion. FOLD THE TOP PORTION OF THE CUSHION UNDER THE BOTTOM PORTION TO FORM A SEATING SURFACE FOR THE CHILD. Be sure seat belt buckles (if equipped) are NOT beneath the two-piece seat cushion. Failure to fold the seat cushion under can result in damage to the restraint and thus improper restraint of the child.

Open chest clip by squeezing middle tabs and pulling chest clip apart.

Unbuckle harness buckle by pressing down on RED release button.

To loosen harness, lift metal at top of seat and pull down on shoulder strap to loosen strap. Repeat with second shoulder strap.

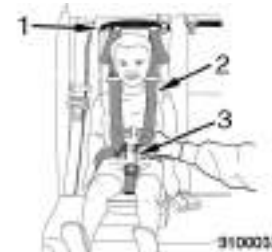

1. Metal Tabs
2. Shoulder Straps
3. Harness Buckle

Place the child in the restraint with the child's back flat against the back of the bus seat cushion. Position shoulder straps over the child's shoulders.

Buckle harness by inserting buckle tongues into harness buckle.

Listen for an audible click when each buckle tongue is fastened.

Check that the buckle connection is secure by pulling on the shoulder straps.





### 1. Top Straps

To tighten harness, pull down equally on top straps on both sides until the harness is snug around the child.

A snug strap should not allow any slack. It lies in a relatively straight line without sagging. It does not press on the child's flesh or push the child's body into an unnatural position.



1. Shoulder Height Adjuster
2. Chest Clip

Fasten chest clip by pushing both sides together, then position chest clip at middle of the child's chest, at armpit level.

Position each shoulder height adjuster at or just above the child's shoulder. Be sure harness is snug and tight on child's thighs and chest.

### CE White Integrated Child Restraint Seats (Optional)



**To prevent property damage, personal injury, and / or death, observe the following:**

**This integrated child seat is designed for use only by children who weigh between 20 and 85 lb (9 and 39 kg).**

Refer to the following illustration to become familiar with the parts of the child seat and five-point seat belts. This child restraint system conforms to U.S. Federal Motor Vehicle Safety Standard 213 and Canada Motor Vehicle Safety Standard No. 213.4

## Seating and Safety Restraints

---

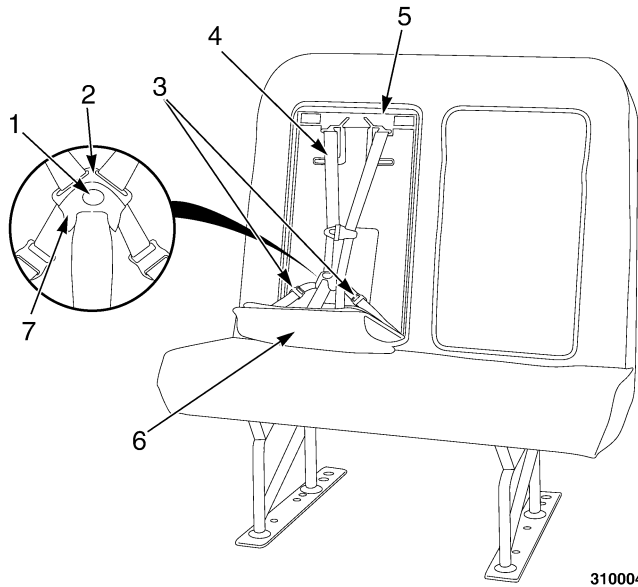

1. Buckle Release Button
2. Seat Belt Latch Plates
3. Adjustment
4. Shoulder Belt Strap
5. Removable Pad
6. Folded Down Leg Rest Pad
7. Buckle

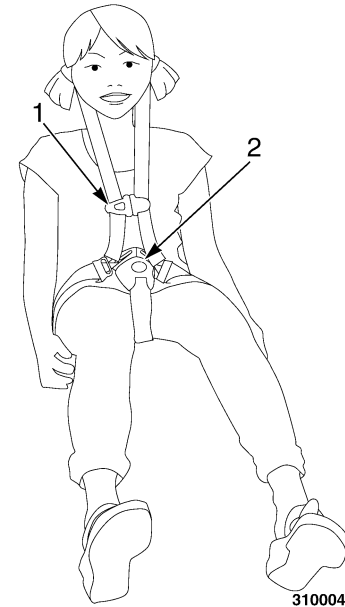

1. Shoulder Belt Clip
2. Seat Belt Latch Plates

To open the child restraint, grasp the upper portion (leg rest pad) and lower the child seat cushion.

To secure the child:

1. Before placing the child in the seat, add slack to the shoulder belts. Release the seat belts by pulling up on the belt adjustment strap, then pull up on the seat belts.

2. Place the child into the child seat, pull the shoulder belts through the appropriate shoulder slot for the height of the child and put a shoulder belt over each shoulder. Insert both seat belts latch plates into the buckle and pull up on them to make sure they are firmly latched.

**NOTE: Be sure that the seat belt buckle is free of foreign objects that may prevent you from properly latching latch plates. If an object is in the opening, and cannot be removed, see your dealer for service immediately.**

3. Fasten the two halves of the shoulder belt clip together and put it 2 - 3 in (5 - 7.6 cm) below the child's chin. The purpose of the clip is to keep the shoulder belts positioned correctly on the shoulders.

To remove the child, reverse Steps 1 through 3.

### Child Restraint Anchorage Systems (Optional)

The following provides information pertaining to attaching add-on child seats to passenger seats with child restraint anchorage systems including tether anchors.

When installing an add-on child seat, follow the instructions located on the add-on child seat for the forward facing position. Ensure that the seat chosen is able to be installed in the forward facing position and is designed to be used with the child restraint anchorage system.

Passenger seats with optional child restraint anchorage systems for attaching add-on child seats are usually located in the first few rows of passenger seats behind the operator and / or entrance door. To determine the location of the passenger seats in the

vehicle that are equipped with child restraint anchorage systems, look for the pockets in the seat back just above the seat cushion with a bar inside, or bars protruding up, between the seat back and the seat cushion. LATCH anchor locations may be identified with the anchorage symbol just above the anchor.

Canadian school buses and all commercial buses must attach the tether of the add-on child seat to the tether anchor located on the passenger seat per the following instructions. To locate the tether anchor (see Location of the Tether Anchor).

**NOTE: Tethers are not required in U.S. school buses in combination with child restraint anchorage system (UCRA) when installing add on child restraint seats.**

Passenger seats may have one or two child restraint anchorage systems. If two anchor systems are present in the same passenger seat, and only one add-on child seat is going to be installed, it is recommended to use the system closest to the wall to improve the mobility of the passenger in the open seat in case of an emergency.



**To prevent property damage, personal injury, and / or death, observe the following:**

**Follow all instructions on the child restraint and in this manual, including the manufacturer's warnings for proper use of the child restraint system and LATCH attachments.**

## Seating and Safety Restraints

---

### Location and Use of Lower LATCH Anchors

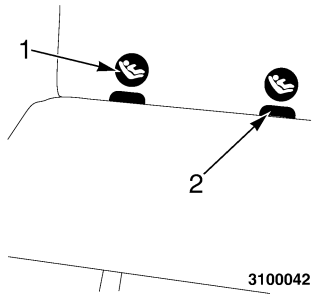

1. Anchorage Symbols
2. Lower LATCH Anchors

### Location of the Tether Anchor (Optional)

The tether anchor style and location may vary between seat manufactures.

IC and CE White seats tether installation is as follows:

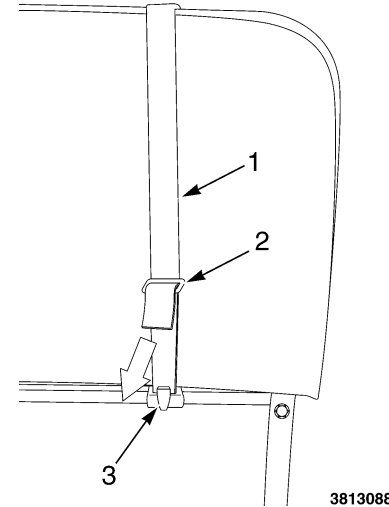

1. Child Strap
2. Adjuster
3. Tether Anchor

**NOTE: IC and CE White tether anchors are mounted to the seat belt bar and are visible under the rear of the seat back.**

For the attachment of an add-on child seat tether, wrap the tether over the seat as shown then connect the snap hook to the tether anchor. Adjust the tether to a snug and tight fit by pulling on the free end of the strap at the adjuster.

### IMMI® Seats Tether Installation

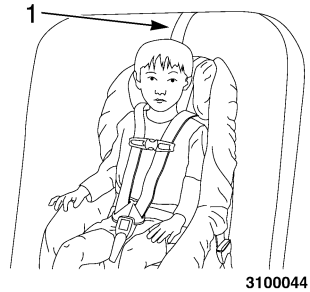

#### 1. Child Seat Tether

All base, three point, and integrated child restraint (BTI) bus seats equipped with LATCH are also equipped with tether anchors for add-on child seats.

#### *Location and Use of Tether Anchors (BTI Bus Seats)*

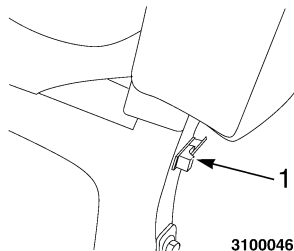

#### 1. Tether Anchor

Tether anchors are located on the aisle side rear pedestal and on the seat wall mount bracket rear edge.

#### *Installing Tether*

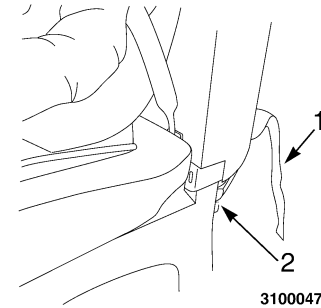

1. Strap (Free End)
2. Tether Anchor

To attach an add-on child seat tether, route the tether on the child seat over the top of the belted BTI bus seat. Extend the tether and connect the snap hook to the nearest tether anchor provision at the lower rear of the seat. Adjust the tether to a snug and tight fit by pulling on the free end of the strap at the adjuster.

## Seating and Safety Restraints

---

### *Location and Use of Tether Anchors (SafeGuard® XChange Bus Seats)*

SafeGuard® XChange bus seats are equipped with tether anchors for add-on child seats.

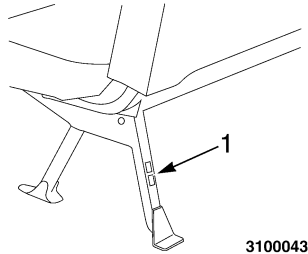

#### 1. Tether Anchor

Tether anchors are located on the aisle side rear pedestal and on the seat wall mount bracket rear edge.

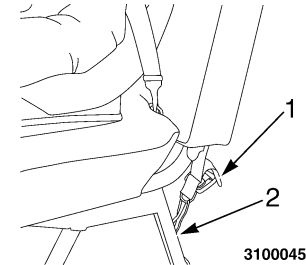

1. Strap (Free End)
2. Tether Anchor

To attach an add-on child seat tether, route the tether on the child seat over the top of the SafeGuard® XChange bus seat. Extend the tether and connect the snap hook to the nearest tether anchor provision at the lower rear of the seat. Adjust the tether to a snug and tight fit by pulling on the free end of the strap at the adjuster.

### Cushion Release Latch



**To prevent property damage, personal injury, and / or death, make sure seat belts and equipment are held out of the way when lowering the cushion to seated position. Keep hands and feet clear while lowering the seat cushion.**

### Rear Latching

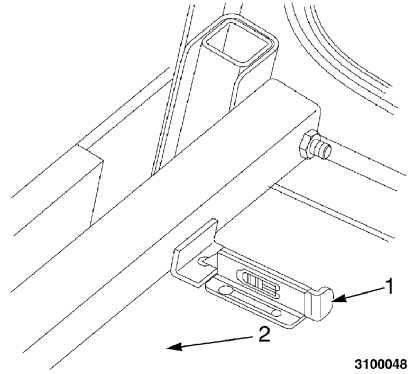

1. Latch
2. Seat Bottom

Optional release latches may vary based on seat style. Seats automatically latch when sat upon. Pull up on seat cushion to confirm cushion is latched.

For both rear and side latching designs, pull the latch to release.

### Side Latching

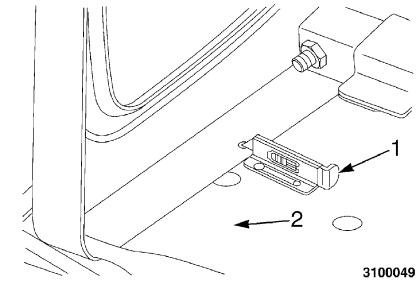

1. Latch
2. Seat Bottom

# Seating and Safety Restraints

## Track Seat Mounting Seat Type Specific

The following diagrams outline the maximum seat spacing for specific seat and barrier types to ensure FMVSS / CMVSS 222 compliance School bus required. Original seat layout for a specific unit can be obtained by contacting your IC Bus dealer.

**NOTICE**

**COMPLIANCE WITH FMVSS-222 PASSENGER CRASH PROTECTION**

1. ALL SEATS MUST FACE FORWARD
2. EACH SEAT MUST BE PLACED BEHIND ANOTHER SEAT OR BARRIER OF MATCHING WIDTH.
3. FOR PROPER SEAT SPACING MEETING FMVSS & CMVSS REQUIREMENTS, SEE OWNERS MANUAL.

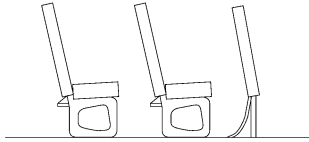

g3100050

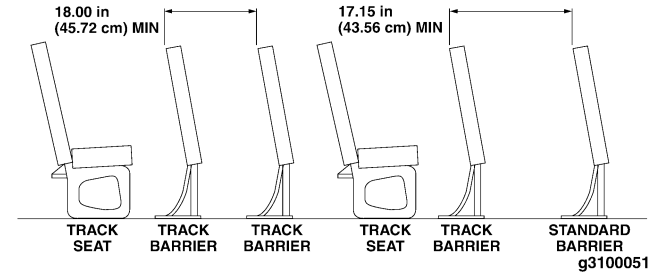

Minimum spacing with standard barrier to track barrier, and track barrier to track barrier.

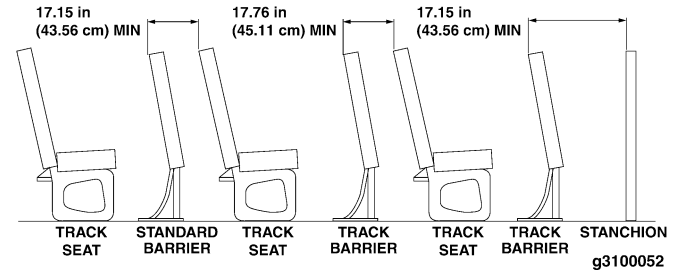

The standard track seat label is found on the front bulkhead of all buses with track seating.

Minimum spacing with stanchion to track barrier, track seat to track barrier and track seat to standard barrier.



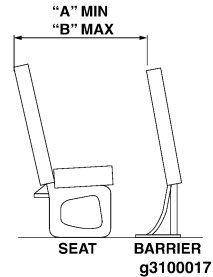

Barrier Type	Seat	A - Minimum	B - Maximum
Standard	IC Track	28.75 in (73.03 cm)	34.35 in (87.25 cm)
Track	IC Track	29.24 in (74.27cm)	34.24 in (86.97 cm)
Standard	CEW-CR11 Track Seat (with or without lap belts, with Integrated Child Seat)	28.51 in (72.41 cm)	32.54 in (82.65 cm)
Track	CEW-CR11 Track Seat (with or without lap belts, with Integrated Child Seat)	29.10 in (73.91 cm)	32.10 in (81.53 cm)
Standard	CEW-QSCR11 Track Seat (with 3 point belts, with Integrated Child Seat)	28.49 in (72.36 cm)	32.52 in (82.60 cm)
Track	CEW-QSCR11 Track Seat (with 3 point belts, with Integrated Child Seat)	29.35 in (74.55 cm)	32.35 in (82.17 cm)
Standard	CEW-QS11 Track Seat (with 3 point belts, without Integrated Child Seat)	28.53 in (72.47 cm)	32.56 in (82.70 cm)
Track	CEW-QS11 Track Seat (with 3 point belts, without Integrated Child Seat)	29.36 in (74.57 cm)	32.36 in (82.19 cm)
Standard	IMMI® Track Seat (without Integrated Child Seat)	30.54 in (77.57 cm)	36.44 in (92.56 cm)
Track	IMMI® Track Seat (without Integrated Child Seat)	30.92 in (78.54 cm)	34.92 in (88.70 cm)
Standard	IMMI® ICS Track Seat (with Integrated Child Seat)	30.54 in (77.57 cm)	36.44 in (92.56 cm)
Track	IMMI® ICS Track Seat (with Integrated Child Seat)	30.92 in (78.54 cm)	35.92 in (91.24 cm)

## Seating and Safety Restraints

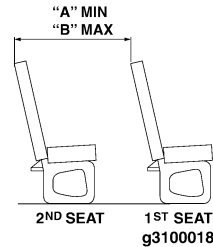

Seat to Seat		Spacing	
First Seat	Second Seat	A - Minimum	B - Maximum
IC Track	IC Track	26.00 in (66.04 cm)	31.00 in (78.74 cm)
IC Track	CEW-CR11 Track Seat (with or without lap belts, with Integrated Child Seat)	25.87 in (65.71 cm)	28.87 in (73.32 cm)
IC Track	IMMI® ICS Track Seat (with Integrated Child Seat)	27.68 in (70.31 cm)	32.68 in (83.01 cm)
CEW-CR11 Track Seat (with or without lap belts, with Integrated Child Seat)	IC Track	29.13 in (73.99 cm)	34.13 in (86.69 cm)
IMMI® ICS Track Seat (with Integrated Child Seat)	IC Track	30.54 in (77.57 cm)	36.44 in (92.56 cm)
CEW-CR11 Track Seat (with or without lap belts, with Integrated Child Seat)	CEW-CR11 Track Seat (with or without lap belts, with Integrated Child Seat)	28.00 in (71.12 cm)	31.00 in (78.74 cm)
CEW-QSCR11 Track Seat (with 3 point belts, with Integrated Child Seat)	CEW-QSCR11 Track Seat (with 3 point belts, with Integrated Child Seat)	28.00 in (71.12 cm)	31.00 in (78.74 cm)
CEW-QS11 Track Seat (with 3 point belts, without Integrated Child Seat)	CEW-QS11 Track Seat (with 3 point belts, without Integrated Child Seat)	27.00 in (68.58 cm)	30.00 in (76.20 cm)

## Seating and Safety Restraints

CEW-QSCR11 Track Seat (with 3 point belts, with Integrated Child Seat)	CEW-QS11 Track Seat (with 3 point belts, without Integrated Child Seat)	27.00 in (68.58 cm)	30.00 in (76.20 cm)
CEW-QS11 Track Seat (with 3 point belts, without Integrated Child Seat)	CEW-QSCR11 Track Seat (with 3 point belts, with Integrated Child Seat)	28.00 in (71.12 cm)	31.00 in (78.74 cm)
IMMI® Track Seat (without Integrated Child Seat)	IMMI® Track Seat (without Integrated Child Seat)	27.00 in (68.58 cm)	31.00 in (78.74 cm)
IMMI® ICS Track Seat (with Integrated Child Seat)	IMMI® ICS Track Seat (with Integrated Child Seat)	27.00 in (68.58 cm)	32.00 in (81.28 cm)
IMMI® Track Seat (without Integrated Child Seat)	IMMI® ICS Track Seat (with Integrated Child Seat)	27.00 in (68.58 cm)	32.00 in (81.28 cm)
IMMI® ICS Track Seat (with Integrated Child Seat)	IMMI® Track Seat (without Integrated Child Seat)	27.00 in (68.58 cm)	31.00 in (78.74 cm)



## SECTION 8 — CLIMATE CONTROLS

### Heater System



To prevent property damage, personal injury, and / or death, observe the following:

Never drive the vehicle unless the windshield and all other windows are clear. A fogged, ice / snow covered, or dirty windshield or window limits vision. To improve defroster efficiency, remove ice and / or snow by hand from the windshield and windows with a non-metallic scraper.

### Driver Heater

The driver heater console is located below the left switch panel.

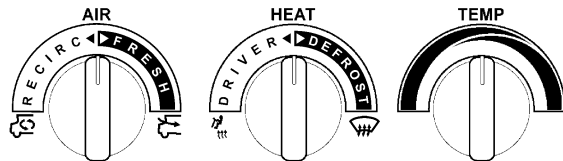

3813094

Adjust the Air knob to provide outside air into the driver area.

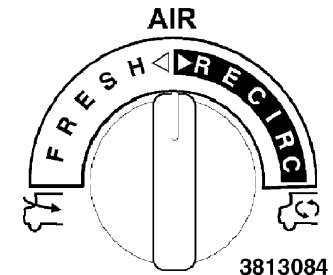

3813084

Adjust the Heat knob to direct the air flow either into the driver area or the defrost area.

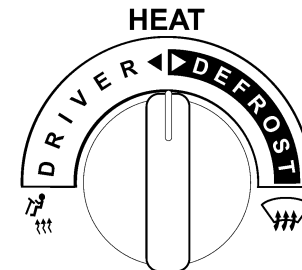

3813095

Three heater control knobs provide air flow direction, fresh air or recirculation control, and temperature selection.

Adjust the Temperature knob to control the temperature of the air through the heater vents.

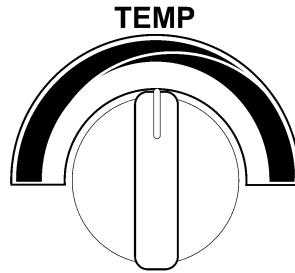

ICB100503

The heater fan speed is controlled by the Driver Heater Defrost fan switch on the left console switch panel.



### Auxiliary Heaters

The Midship / Rear heater switches provide blower speed control for the passenger compartment heaters and are located on the left switch panel. The control switch is labeled OFF / LO / HI.

### Defrost Operating Instructions

The defroster blower is controlled by the three-position (OFF / LO / HI) DRIVER HEATER / DEFROST fan switch, located on the left switch panel. Press the switch to the desired position to control blower speed.

Air is directed through the defrost duct to the windshield and side window outlets utilizing the Defrost Climate Control Heat selector. Use this mode at maximum fan speed and temperature setting for best windshield and side window defrosting.

If equipped, the optional step well heater may be turned on for added air flow to the defroster vents.

### Auxiliary Fuel-Fired Heater System (Optional)

#### Introduction

The auxiliary heater system is designed to provide additional heating capacity in cold weather conditions.

The auxiliary heater system is connected directly into the fuel and power supply of the bus: therefore, external hook-ups are not needed and the auxiliary heater system can be operated no matter where the bus is located.

**Description**

The auxiliary heater system consists of a fuel fired coolant heater, coolant plumbing, and wiring. The coolant plumbing connects the coolant heater to the engine and body heating system. The coolant heater location will vary, but is typically mounted on the left frame rail near the front of the bus. A fuel line is connected to the fuel tank to supply the coolant heater. An exhaust tube is routed from the coolant heater out the left side of the bus.

When turned on, fuel is supplied to the coolant heater and is ignited by a glow pin that establishes a flame that heats the coolant. The heated coolant is circulated through the bus coolant system and the engine block.

**NOTE: The coolant heater is also equipped with safety features such as a flame sensor, temperature sensor, and overheat sensor that constantly monitor the coolant heater and will shut down if any problems occur.**

**Operation**



**To prevent property damage, personal injury, and / or death, the auxiliary heater system must be OFF before filling any fuel tank or moving the vehicle into an enclosed area where combustible fumes may be present.**



**To prevent property damage, personal injury, and / or death, the auxiliary heater system must not be operated in garages or other enclosed areas without properly venting the heater unit exhaust to the outside.**



**To prevent property damage, personal injury, and / or death, the use of this auxiliary heater system requires that the engine coolant be of a proper mixture so as to prevent freezing or slushing. Refer to the engine manufacturer's manual for specific coolant mixture recommendations. Frozen or slushy coolant can cause a blockage leading to rapid pressure buildup in the system hoses.**

**Heater Control Switch**

Turn the Booster Pump switch to the ON position to enable the auxiliary heater system. The Booster Pump switch is located in the left console switch panel.

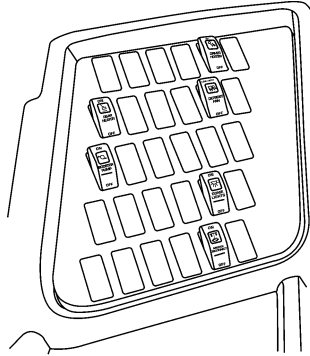

ICB100043



**NOTE:** On initial start-up, the heater may require several start attempts to self-prime the fuel system.

Once switched on, the following sequence occurs:

### Heating Mode

**NOTE:** If the heater should shut down due to flame out while in running mode, it will automatically attempt one restart. If successful, it will continue to run. If not, it will shut down completely with a cool-down cycle.

**NOTE:** During operation, the heater continually senses the input voltage from the batteries. If the input voltage drops to approximately 12.1 volts or rises above 16 volts, the heater will automatically shut down with a cool-down cycle.

Depending on the heat requirements, the heater is automatically controlled in stages:

1. HIGH
2. LOW
3. OFF (controlled pause)

The temperature limits are permanently programmed in the electronic control unit.

Once ignition is successful, the following operations take place:

**NOTE:** If the heater fails to start the first time, it will automatically attempt a second start. If unsuccessful, the heater will shut down completely.



**Switching-Off Sequence**

To turn the system off, set the Booster Pump switch to the OFF position. When the heater is switched off, manually or automatically, it starts a controlled cool-down cycle:

1. The fuel supply is shut off and the flame is extinguished.
2. The combustion air blower and coolant pump continue to run for 130 seconds to cool down.
3. The heater shuts off.

**NOTE: An optional programmable seven day timer is available for the auxiliary fuel-fired heater system. Follow manufacturer's guide for operating instructions.**

**Air Conditioning**

Your bus may have an aftermarket air conditioning system. Check the manufacturer's operator guide for operating instructions.

**Integrated Air Conditioning System (IC Air)**

This vehicle may be equipped with an optional skirt-or roof-mounted, factory-installed Integrated Air Conditioning (IC Air) system. Before operating the system, become familiar with the climate control system operating controls.

Becoming familiar with your IC Air climate control system operating controls will enable you to realize maximum system performance and maintain a comfortable environment for you and your passengers.

The system controls consists of two rotary switches, one controlling the evaporator fans and the other controlling the thermostat. The following illustration will identify both switches of the control system.

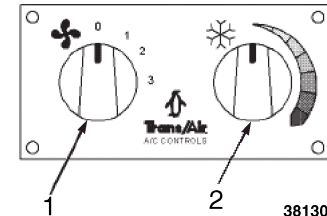

Item #	Name	Functional Description
1	System Off / Fan Speed control: This control has four (4) positions: 0 thru 3	<ul style="list-style-type: none"> <li>• The 0 position is the system Off position.</li> <li>• Position 1 = Low evaporator fan speed.</li> <li>• Position 2 = Medium evaporator fan speed.</li> <li>• Position 3 = High evaporator fan speed.</li> </ul>
2	Air Conditioned Temperature Control	Clockwise = Cooler Counter Clockwise = Warmer.

### Circulation Fans



**To prevent property damage, personal injury, and / or death, wait until the motor cools off before repositioning the circulation fan as the fan motor can become extremely hot when operated in normal ambient temperatures for long periods of time.**

Some buses are equipped with circulation fans. The controls are labeled RIGHT FAN and LEFT FAN and are located on the left switch panel driver console. Each fan has OFF / LO / HI speed control.

Each fan can be positioned in several directions. First turn its fan control switch to the OFF position and then grasp the cage and pivot fan to the desired position to reposition the fan.

## Heater Booster Pump

The optional heater booster pump assists coolant flow from the engine and increases heater performance. Turn the heater booster pump ON to provide the vehicle with additional interior heat.

**NOTE:** Do not use the heater booster pump unless the heater cut-off valve is manually opened.

## Heater Cut-Off Valve

**NOTE:** The illustration is for reference only and may differ from the actual vehicle.

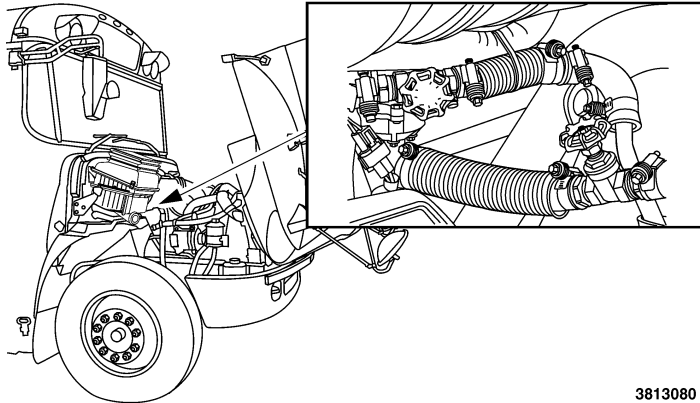

3813080

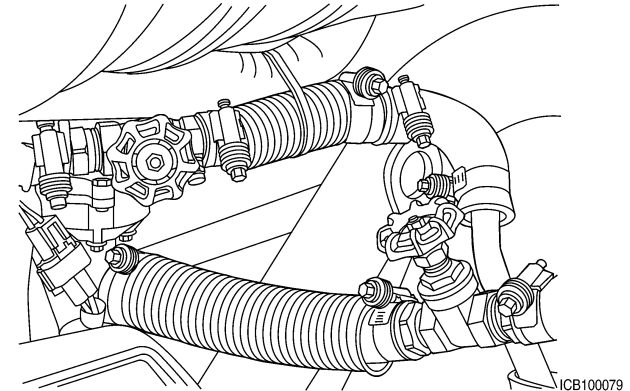

### Typical Heater Cut-Off Valve

The heater cut-off valve for the coolant supply is under the hood.

Turn the heater cut-off valves ON (counterclockwise) whenever the heater is used.

Turn the heater cut-off valves OFF (clockwise) to stop hot coolant from being routed into the bus on hot days.



---

## SECTION 9 — OPERATION

### Starting Procedures

#### Starting the Engine



To prevent property damage, personal injury, and / or death, observe the following:

Do not operate a diesel engine near flammable vapors as this may cause the engine speed to increase uncontrollably and overspeed.

*Turning off the ignition key /switch will not slow or stop the engine due to uncontrollable fueling of the engine through flammable vapors being drawn into the engine air inlet.* Operation of components such as starter, alternator, electric motors, and static electricity could also ignite flammable vapors.

Do not operate the bus in the possible presence of flammable vapors unless both a complete hazard analysis is performed and necessary additional safety processes and / or equipment such as vapor testing, air intake shutoff devices and ventilation, are utilized. The operator is responsible for using those processes and / or equipment to ensure that the diesel engine and all other components on the bus can be operated safely under the specific conditions and hazards that may be encountered.



To prevent property damage, personal injury, and / or death, do not use volatile starting aids such as ether, propane, or gasoline in the engine air intake system. Glow plugs and / or grid heater will ignite vapors, which are an explosion hazard.



To prevent property damage, personal injury, and / or death, never add gasoline, gasohol, and / or alcohol to diesel fuel. This mixture creates an extreme fire and explosion hazard.



To prevent property damage, personal injury, and / or death, never start the engine unless you're sure the transmission selector is in Neutral and the brake is applied; otherwise, accidental movement of the vehicle can occur.



To prevent property / engine damage, personal injury, and / or death, do not operate an engine beyond the maximum governed speed.

## Operation

---



To prevent property damage, personal injury, and / or death, never operate engines in enclosed areas without abundant forced ventilation (with garage doors and windows wide open), since exhaust gases from engines contain hazardous compounds. Maintain exhaust system in good operating condition.



To prevent property damage, personal injury, and / or death, pay strict attention to the following:

Care should be taken to prevent sudden accelerations when both drive wheels are on a slippery surface. This could cause both drive wheels to spin and allow the vehicle to slide sideways, resulting in loss of vehicle control.

**NOTE:** Refer to the Engine Operation and Maintenance Manual supplied with your vehicle for special starting procedures.

### *Automatic Transmission Starter Interlock.*

Automatic transmissions must be in neutral before the starter will engage.

**NOTE:** Use of the cupholder during operation of the vehicle should be in accordance with state regulations, school district guidelines and bus providers operating policies.

**NOTE:** Refer to the Engine Operation and Maintenance Manual supplied with your vehicle for special starting procedures.

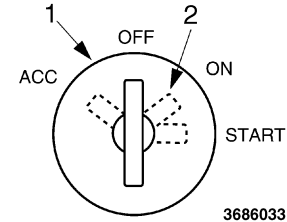

1. Key Switch
2. Key Position

**NOTE:** When the ignition switch is in the ON position, the brake system motor / pumps may be heard as they run briefly to maintain pressure in the system (see Brake section for a complete description).

1. Apply the parking brake. Place the transmission in the neutral position. Turn OFF the headlights and all accessories.
2. Turn the ignition switch clockwise to the ON position. If the WAIT TO START indicator comes on, which means the glow plugs are warming up, wait until the indicator goes out and then proceed.
3. Turn the key to the START position.
4. Do not press the accelerator when starting the engine.
5. When the engine starts, release the key.

If the engine does not start after 30 seconds of cranking, allow two to three minutes for the starter to cool before trying again. If the engine does not start after three attempts, determine the cause. Excessive cranking may damage the starter.

### After the Engine Starts



**To prevent property damage, personal injury, and / or death, if the "CHECK ELEC SYS" indicator illuminates and stays on, a major electrical system failure has occurred. Stop the vehicle and inspect critical accessories and gauges to determine driveability. Have vehicle repaired immediately.**



**To prevent property damage, personal injury, and / or death, if the "CHECK ELEC SYS" indicator illuminates and goes out after one minute, there is an active fault somewhere in the electrical system. Stop vehicle and inspect operation of exterior lamps to determine driveability.**

**NOTE: Refer to the Engine Operation and Maintenance Manual supplied with your vehicle for special starting procedures.**

On some engines, the WAIT TO START indicator illuminates after the engine starts. Allow the engine to idle about three

minutes or until the engine coolant temperature gauge begins to rise. Maintain idle speed until the WAIT TO START indicator cycles off (approximately six minutes), which means the glow plugs have shut off.

- Do not increase engine speed until the oil pressure gauge indicates normal pressure.
- Make sure the engine oil pressure is indicated on the gauge within 20 seconds after starting.
- Idle the engine for three to five minutes before operating with a full load.
- Avoid extended idling (beyond 10 minutes) whenever possible. To maximize engine and Diesel Particulate Filter (DPF) life, see exhaust diesel particulate filter regeneration in this section for more information.
- When starting a cold engine, increase the engine speed (RPM) slowly to make sure adequate lubrication is available to the bearings.

### Engine Features

The engines are electronically controlled diesel engines. The engine Electronic Control Module (ECM) monitors and controls the injection process and other engine functions. The ECM also communicates with the Body Controller (BC) and alerts it to out-of-range operating conditions. The BC, in turn, generates engine function indicators and warning indicators. Since many of the engine performance features are owner selectable and electronically programmable, some of the operating parameters will vary from vehicle to vehicle.

## Operation

---

### Certified Clean Idle

The engines have been designed to meet the new California Air Resources Board (CARB) idle reduction standards by generating less than 30-g/hr NOx emissions when idling. These engines can be identified by the Certified Clean Idle decal located on the left side of the hood or driver's door.

### HD-OBD Overview

The HD-OBD system uses many individual pre-programmed "monitors" to ensure the vehicle is meeting emissions standards. An HD-OBD monitor is a strategy to evaluate the performance of an emissions related system or component. All monitors are designed for execution in a prescribed frequency; some monitors run continuously, while some run a specific ratio against the number of drive cycles.

The operator will be alerted to emissions or other system problems when the Malfunction Indicator Lamp (MIL) illuminates. When the MIL illuminates, bring the vehicle in for service at the next available opportunity. The HD-OBD system does not change the way the vehicle should be driven, the recommended driving style, or the way you use the vehicle.

### Self Diagnostics

All Warning Lamps are located on the instrument panel gauge cluster. When the ignition switch is turned ON, the Warning Lamps are illuminated and remain on while the ECM runs normal start-up tests, then goes OFF. If a warning lamp stays on or comes on while operating the vehicle, it is an indication that the vehicle needs service. When the warning lamp is illuminated, a Diagnostic Trouble Code (DTC) will be generated. Take the

vehicle to a service center as soon as possible as some optional features and / or engine power may be lost while the indicator is lit.

## Fuel

### Ultra-Low Sulfur Diesel Fuel Requirements

Ultra Low Sulfur Diesel (ULSD) fuel is required for all on-highway diesel engines used with advanced after-treatment systems (Diesel Particulate Filters – DPF). For complete details on fuel requirements, see the Engine Operator and Maintenance Manual supplied with the vehicle.

### Unacceptable Fuel Blends

Biodiesel blends having more than 5% pure biodiesel are not within ASTM D975 diesel specifications.

To determine acceptable biodiesel and biodiesel blends, refer to the Engine Operator and Maintenance Manual for the applicable engine.

### Hazards of Diesel Fuel / Gasoline Blends



**To prevent property damage, personal injury, and / or death, never add gasoline, gasohol, and / or alcohol to diesel fuel. This mixture creates an extreme fire and explosion hazard.**



Blending of gasoline and / or alcohol with diesel fuel is not recommended due to the hazards of fire / explosion and the detrimental effects on engine performance.

As little as 2% volume gasoline mixed with diesel fuel will create a flammable / explosive mixture in the fuel tank vapor space, which will pose an extreme fire / explosion hazard during refueling or engine operation.

### Additional Unsafe Practices



**To prevent property damage, personal injury, and / or death, never overfill the fuel tank. Overfilling the tank could cause fuel spillage and / or increased pressure inside the fuel tank. Pressure in an overfilled tank may cause leakage in the fuel system, which could result in a potential fire / explosive hazard.**

### CAUTION

**To prevent vehicle and / or engine damage, do not mix propane with diesel fuel. Warranty claims will not be honored against engines that have used propane.**

### CAUTION

**To prevent engine damage, do not mix engine oil with diesel fuel. Warranty claims will not be honored against engines that have used fuel mixed with oil.**

### Fuel and Lubricant Additives

International trucks are designed and built to operate satisfactorily on fuels and lubricants of good quality marketed by the petroleum industry. Use of any supplementary fuel or lubricant additives is not recommended. Malfunctions attributed to the use of such additives or failure to follow recommended fuel or lubricant recommendations may not be covered by any applicable warranty.

### Fueling Procedures

**NOTE: If your vehicle is equipped with dual fuel tanks, be sure to read and understand the following information before refueling the vehicle.**

A dual tank system contains a primary and a secondary fuel tank.

With dual fuel tanks, the vehicle will be equipped with a fuel transfer pump system that will pump fuel from the secondary (reserve) fuel tank and send it to the primary (draw) fuel tank. The draw fuel tank must have fuel in it at all times, otherwise the vehicle may stall and may be difficult to restart (the fuel gauge reads the fuel level only from the draw fuel tank).

Therefore, when refueling, be sure that both tanks are filled completely, as it is sometimes difficult to determine which tank is the draw tank and which is the reserve tank.

## Operation

---

### Fueling Precautions

**Federal Motor Carrier Safety Regulations require the driver or any employee of a motor carrier to observe the following requirements:**

1. Do not fuel a motor vehicle with the engine running, except when it is necessary to run the engine to fuel the vehicle.
2. Do not smoke or expose any open flame in the vicinity of a vehicle being fueled.
3. Do not fuel a motor vehicle unless the nozzle of the fuel hose is continuously in contact with the intake pipe of the fuel tank.
4. Do not permit any other person to engage in such activities as would be likely to result in fire or explosion.

### Reserve Fuel

No extra supply of fuel for the propulsion of the vehicle or for the operation of accessories shall be carried on any motor vehicle, except in a properly mounted fuel tank or tanks.

### Restarting After Running Out of Fuel

It may be necessary to bleed the fuel system. Refer to Bleeding Air From Fuel System in the Engine Operation And Maintenance Manual supplied with your vehicle.

### Engine Brake, Exhaust Brake, or Retarder (Optional)



**To prevent property damage, personal injury, and / or death, do not use the vehicle retarder, engine or exhaust brake on slippery road surfaces. Doing so may cause wheel slippage and / or loss of vehicle control.**

**NOTE: The engine or exhaust brake should never be considered a substitute for the vehicle service brakes. The service brakes should always be viewed as the primary vehicle slowing system. Service brakes are always used to bring vehicle to a complete stop.**

#### *Engine and Exhaust Brake Systems Operation*

Vehicles, with MaxxF<sup>®</sup> DT, 9, or 10 engines, utilize either the optional Diamond Logic<sup>®</sup> Engine Brake or the optional Diamond Logic<sup>®</sup> Exhaust Brake for additional braking in various operating conditions.

The optional **Diamond Logic<sup>®</sup> Engine Brake** is a compression style brake that utilizes the injection control system pressure and the closed vanes of the turbocharger for maximum braking power. The Engine brake is controlled by the switch panel switches:



ENGINE BRAKE ON / OFF, and ENGINE BRAKE SELECTOR 1 / 2 / 3. To activate the engine brake, place the ENGINE BRAKE ON / OFF to the ON position (the switch indicator will

turn on). The ENGINE BRAKE SELECTOR 1 / 2 / 3 switch is used to adjust the amount of braking applied.

**NOTE: The ECM will not allow the Diamond Logic® Engine Brake to operate until the engine oil has reached the acceptable minimum temperature, therefore, do not attempt to activate the engine brake until the engine has reached full operating temperature.**

The optional **Diamond Logic® Exhaust Brake** accomplishes the braking effects using the closed vanes of the turbocharger to increase exhaust back-pressure and restrict airflow. The exhaust brake is controlled by the EXHAUST BRAKE ON / OFF switch, located in the switch panel. To turn the exhaust brake ON, place the EXHAUST BRAKE ON / OFF switch to the ON position (the switch indicator will turn ON).

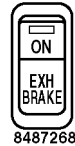

**NOTE: Both the engine brake and exhaust brake features will automatically deactivate if either the accelerator or the clutch is pushed, or when the engine speed falls to 1000 RPM.**

### *Operational Modes*

**Coast Mode.** In the coast mode, with the brake enabled, the brake will activate when the driver hits the service brake (at or above 1200 rpm). The brake will deactivate if the driver releases the brake pedal, or if the engine speed drops below 1200 rpm.

**Latched Mode.** In the latched mode, with the brake enabled, the braking will activate when the driver's foot is lifted from the accelerator pedal (at or above 1200 rpm). If the Cruise ON / OFF switch is in the ON position (with or without a Cruise set speed),

the braking is activated by hitting the brake pedal. The braking action will cease if the driver presses the accelerator, the clutch, or if the engine speed drops below 1200 rpm.

**Cruise Mode.** The cruise mode operates the same as the latched mode, except that if the driver has the Cruise turned on, the braking action helps to maintain the set speed. This feature is especially valuable when going down a grade.

## Exhaust Aftertreatment

### Selective Catalytic Reduction System (If Equipped)

#### *Introduction*

Selective Catalytic Reduction (SCR) is the aftertreatment technology that treats exhaust gas downstream of the engine. It uses a urea-based Diesel Exhaust Fluid (DEF) and a catalyst to significantly reduce nitrogen oxide (NOx) emissions.

#### *Diesel Exhaust Fluid*

Diesel Exhaust Fluid (DEF) is nontoxic, nonflammable, and biodegradable. It is a carefully blended aqueous urea solution of 32.5% high-purity urea and 67.5% deionized water.

If stored between 10° and 90°F (-12° and 32°C), DEF has shelf life of 12 months minimum. For best shelf life, DEF containers should be stored in a controlled environment out of direct sunlight.

The amount of DEF consumption depends on engine speed and load; therefore, it differs from vehicle to vehicle.

### CAUTION

To prevent property damage, IC Bus requires the use of Diesel Exhaust Fluid (DEF) that meets or exceeds ISO-22241-1. There is no acceptable substitute.

IC Bus recommends using Fleetrite® brand Diesel Exhaust Fluid.

#### *DEF Tank*

The DEF tank filling inlet is located on the right side of the vehicle, near the fuel tank door and behind a fill door labelled DEF Fluid. For reference, see Figure Exterior Components in section **Model Description > Exterior Components**.

The filler neck inlet on a DEF tank has a blue cap and has a smaller diameter (19 mm) than that of a filler neck on the diesel fuel tank.

The SCR system is designed to operate normally also under freezing conditions while containing DEF. Though DEF freezes at approximately 10°F (-12°C), no operator interaction is necessary when operating in cold temperatures.

Under cold or very dry conditions, water vapor can be seen coming from the vehicle tailpipe. This is normal system operation. The water vapor will disappear within a few minutes of normal vehicle operation.

After the key is turned OFF on a vehicle with SCR system, a pumping sound may be heard from underneath the vehicle. The sound is made by the Aftertreatment DEF dosing unit while it purges any unused DEF from the system and returns it to the

DEF tank. This is normal system operation. It takes about 70 seconds to complete.

### CAUTION

To prevent vehicle / property damage, after turning the key OFF on a vehicle with Selective Catalyst Reduction (SCR) system, do not disconnect the vehicle batteries while you can hear a pumping sound from underneath the vehicle. The sound may last for about 60 seconds.

#### *Low DEF Level*







To prevent property damage, personal injury, and / or death, maintain the adequate Diesel Exhaust Fluid (DEF) level to avoid a loss of engine power and vehicle speed.

On the instrument panel, you can monitor the fluid level using the DEF Level Gauge. You will see additional warnings if the DEF is too low. If DEF level decreases to 2.2% or lower, the engine performance will start to be de-rated by at least 25%. If the DEF level remains 0% for an extended time, the vehicle speed will be limited to 5 mph (8 km/h). Refill the DEF tank with approved DEF at any point, and the vehicle will resume normal operation.

See the following table for a detailed explanation of indicators about low DEF level.

Indicators about Low DEF level (For Vehicles Equipped with Cummins® ISB Engines)



Level	Indication	Audible Alarm	LCD Text Message	Vehicle Conditions / Operation
1	 (Solid)	1 Beep	Scrolls between SEE VISOR FOR INFO and DEF LOW REFILL SOON.	Initial Warning - normal engine operation. DEF level is 10% or lower.
2	 (Flashing)	1 Beep	Scrolls between SEE VISOR FOR INFO and DEF LOW REFILL SOON.	Initial Warning - normal engine operation. DEF level is 5% or lower.
3	 (Flashing)  (Solid)	1 Beep	Scrolls between SEE VISOR FOR INFO, DEF LOW ENG DERATED 25%, and WARN ENGINE.	Engine performance is <b>LIMITED</b> . DEF level is 2.5% or lower.

## Operation

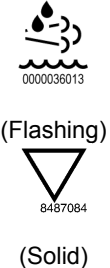
### Indicators about Low DEF level (For Vehicles Equipped with Cummins® ISB Engines) (cont.)

Level	Indication	Audible Alarm	LCD Text Message	Vehicle Conditions / Operation
4	 <p>0000036013</p> <p>(Flashing)</p> <p>8497084</p> <p>(Solid)</p>	1 Beep	Scrolls between SEE VISOR FOR INFO, DEF LOW ENG DERATED 40%, and WARN ENGINE.	Engine performance is <b>LIMITED</b> . DEF level is 0%.

Indicators about Low DEF level (For Vehicles Equipped with Cummins® ISB Engines) (cont.)

Level	Indication	Audible Alarm	LCD Text Message	Vehicle Conditions / Operation
5	 (Flashing)  (Solid)  (Solid)	1 Beep	Scrolls between SEE VISOR FOR INFO, DEF LOW ENG DERATED 5MPH, WARN ENGINE, and STOP ENGINE.	Vehicle speed is limited to 5 mph (8 km/h).

DEF Contamination or SCR System Fault



To prevent property damage, personal injury, and / or death, seek service immediately if Diesel Exhaust Fluid (DEF) contamination or Selective Catalyst Reduction (SCR) system fault is detected.





- Failure to resolve the problems may result in a loss of engine power and vehicle speed, and may cause an accident.

If incorrect liquid is in the DEF tank or if some other fault is detected within the SCR system, the Amber Warning Lamp or Malfunction Indicator Lamp will illuminate. If no action is taken in the initial warning stages, engine performance will be de-rated by at least 25%, and eventually vehicle speed may be limited to 5 mph (8 km/h).

See the following tables for detailed explanation of DEF or SCR system indicators.







## Operation

### Indicators about DEF Quality Problem (For Vehicles Equipped with Cummins® ISB Engines)



Level	Indication	Audible Alarm	LCD Text Message	Vehicle Conditions / Operation
1		1 Beep	Scrolls between DEF QUALITY SERVICE SOON and WARN ENGINE.	Initial Warning - fault code has been set.
2		1 Beep	Scrolls between DEF QUALITY DERATED 25% and WARN ENGINE.	Engine performance is de-rated by at least 25%.
3		1 Beep	Scrolls between DEF QUALITY DERATED 40% and WARN ENGINE.	Engine performance is progressively de-rated by up to 40%.
4		1 Beep	Scrolls between DEF QUALITY DERATED 5MPH, WARN ENGINE, and STOP ENGINE.	Engine performance is de-rated by 40%. Vehicle speed is limited to 5 mph (8 km/h).



Warnings of SCR System Fault (For Vehicles Equipped with Cummins® ISB Engines)

Level	Indication	Audible Alarm	Vehicle Conditions / Operation
1	 or 	1 Beep	Initial Warning - fault code has been set.
2	 or 	1 Beep	Engine performance is de-rated by at least 25%.
3	 or 	1 Beep	Engine performance is progressively de-rated by up to 40%.

Warnings of SCR System Fault (For Vehicles Equipped with Cummins® ISB Engines) (cont.)

Level	Indication	Audible Alarm	Vehicle Conditions / Operation
4	 <p>8487084</p> <p>or</p>  <p>3813053</p> <p>and</p>  <p>8487086</p>	1 Beep	Engine performance is de-rated by 40%. Vehicle speed is limited to 5 mph (8 km/h).

## Exhaust Diesel Particulate Filter Regeneration

This vehicle is equipped with a Diesel Particulate Filter (DPF) to meet 2010 emissions requirements. The DPF traps exhaust particulate matter generated by normal engine usage. Periodically, the engine control system will perform a “cleaning” of the filter, known as Normal Regeneration. This process is transparent to the operator and occurs during normal vehicle operation.

In some cases the engine control system is unable to manage soot levels in the DPF through Normal Regeneration. When this occurs the DPF indicator will illuminate solid YELLOW on the instrument panel gauge cluster advising that action must be taken. At this time the vehicle should then be driven at highway speeds, or pulled over to perform a Parked Regeneration (See Parked Regeneration Procedure).

If no action is taken during the previous warning stage, the DPF indicator will begin to flash indicating that the filter is full. The vehicle should then be pulled safely off the roadway and a Parked Regeneration should be performed.

If the vehicle is driven beyond the initial two warning stages, a loss of engine performance (de-rate) will occur. Ignoring the need for a Parked Regeneration, when required, can result in a warning for excessive exhaust temperatures, and a requirement to shut the engine off and not restart it until the DPF has been serviced by a technician. It is important to perform a Parked Regeneration when required. Failure to do so could be mission disabling and result in the vehicle being towed.

See the following information for a detailed explanation of DPF indicators and the corresponding procedures that must be followed.



**To prevent property damage, personal injury, and / or death, do not perform a Parked Regeneration when Diesel Particulate Filter (DPF) indicator is ON as this will cause the engine to lose power and eventually shut down.**

**When performing Parked Regeneration, make certain vehicle is safely off of the roadway and exhaust pipe is away from people, or any flammable materials or structures.**



**Failure to follow these instructions may result in a loss of engine power and vehicle speed, increased exhaust temperatures, and an accident or fire.**

There will be three levels of indication that the vehicle’s exhaust filter is accumulating soot and needs to be cleaned, each with an increasing urgency for action.







**NOTE: A Level 1 indication may disappear or a Level 2 may revert to a Level 1, if the vehicle is driven on highway at highway speeds for an extended period. This process of auto regeneration of the exhaust filter is activated when the engine load is increased as a result of highway driving at highway speeds. If the DPF indicator does not reduce in level or disappear, a Parked Regeneration must be performed.**

**NOTE: The following table is a typical representation of 2010 DPF emissions procedures.**

**Diesel Particulate Filter (DPF) Regeneration Table**

Level	Engine Option	Indication	Audible Alarm	LCD Text Message	Vehicle Conditions / Operation	Action Required
1	All	 <p>DPF 3813052 (Solid)</p>	None	Scrolls between SEE VISOR FOR INFO and PARKED REGEN REQUIRED.	Exhaust filter regeneration required.	Drive on highway at highway speeds or start Parked Regeneration to prevent loss of power.
2	All	 <p>DPF 3813052 (Flashing)</p>	None	Scrolls between SEE VISOR FOR INFO and PARKED REGEN REQUIRED.	Exhaust filter is full.	Pull vehicle safely off roadway and start Parked Regeneration to prevent loss of engine power.

**Diesel Particulate Filter (DPF) Regeneration Table (cont.)**

3	Navistar's engines only	 DPF 3813052 (Flashing)	An alarm will beep continuously while ignition is on.	Scrolls between SEE VISOR FOR INFO and PARKED REGEN REQUIRED.	Exhaust filter is full. Engine performance is <b>LIMITED</b> .	 <b>WARNING</b>  To prevent property damage, personal injury, and / or death, pull vehicle safely off roadway and start <b>Parked Regeneration</b> to prevent engine stopping.
	Cummins® ISB only	 DPF 3813052 (Flashing)  8487084 (Solid)				
<div style="display: flex; justify-content: space-between; align-items: center;"> <div style="text-align: left;">   <b>TEMP</b>                  3813051             </div> <div style="text-align: center;"> <p><b>Exhaust System Temperature is HOT</b></p>  <b>WARNING</b> </div> </div> <p style="text-align: center;"><b>To prevent property damage, personal injury, and / or death, keep exhaust components away from people and flammable materials, vapors, or structures, and STOP ENGINE. Exhaust components, operating under normal conditions, and exhaust gases are at extremely high temperatures.</b></p>						
<div style="display: flex; justify-content: space-between; align-items: center;"> <div style="text-align: left;">                   8487086             </div> <div> <p>A serious problem has occurred. Engine may <b>SHUT DOWN</b> soon. Pull vehicle safely off roadway, turn on flashers, set parking brake, place warning devices, and <b>STOP ENGINE</b>. Seek service immediately.</p> </div> </div>						

## Operation

---

### *Parked Regeneration Procedure*

Perform the following steps to initiate Parked Regeneration (cleaning) of the exhaust filter:

1. Park the vehicle safely off the roadway and away from flammable materials.
2. Before initiating parked regeneration (using the ON / PARKD REGEN switch), the following conditions must be in place:
  - a. Parking brake must be set.
  - b. DPF indicator illuminated (Solid or Flashing).
  - c. Transmission must be in Neutral (N) or Park (P), if available.
  - d. Accelerator, foot brake and clutch (if present) pedals must not be depressed.
  - e. Engine temperature must be at a sufficient level to allow regeneration.

With some engines, this may be as high as 170°F (77°C).

**NOTE: The engine coolant temperature must be above 77°C (170°F) before the parked regeneration procedure can be performed. If the engine coolant temperature is too low, the parked regeneration procedure will not activate.**

3. Press the ON position of the ON / PARKD REGEN switch to initiate the regeneration cycle.

The engine speed will automatically ramp up to a preset RPM, PARKD REGEN ACTIVE will be displayed in the

information display, and the switch indicator will illuminate when the cycle is started. If the indicator is blinking, check to be sure that all conditions in Step 2 have been met. Once started, the regeneration cycle will last approximately 30 minutes.

**NOTE: If any of the above conditions are altered during the Parked Regeneration process, regeneration will be halted and must be restarted.**

4. When the regeneration cycle is complete, the switch indicator will go off, the engine RPM will return to normal idle and all exhaust filter warning indicators will be off. The vehicle may now be driven normally.



**NOTE: In the event of an emergency where the vehicle must be moved after beginning Parked Regeneration, press PARKD REGEN position of the ON / PARKD REGEN switch to cancel Parked Regeneration.**

### *Regeneration Inhibit Switch*

The optional Regeneration Inhibit switch is used to prevent the normal regeneration or parked regeneration processes.



**NOTE: There are two versions of the regeneration inhibit switch: the two-position and the three-position switch. Therefore, it is necessary to verify which version is installed in this vehicle. Both versions have the same switch labels.**

### *Two-Position Regeneration Inhibit Switch*

With the optional two-position switch, pressing the ON position of the ON / INHIBT REGEN switch will inhibit both normal and parked regeneration. Regeneration will be inhibited (latched) when in this position and the switch indicator is turned on.

### *Three-Position Regeneration Inhibit Switch*

The optional three-position switch is a center stable momentary switch. Pressing the ON position inhibits normal regeneration while the engine is running and is reset when the ignition switch is turned off. The Inhibit function is cancelled when the lower position is pressed, or parked regeneration is initiated (PARKD REGEN switch is turned to the ON position).

The switch indicator will be turned on whenever regeneration inhibit is enabled.

## **Restarting After Running Out of Fuel**

It may be necessary to bleed the fuel system. Refer to Bleeding Air From Fuel System in the Engine Operation And Maintenance Manual supplied with your vehicle.

## **Cold Weather Operation**

### **INSTRUCTIONS**



**To prevent property damage, personal injury, and / or death, do not use the washers in freezing weather without first warming the windshield with the defrosters; otherwise, the washer solution may freeze on the windshield and obscure your vision, which could cause an accident.**

**Do not use radiator coolant or antifreeze in the windshield washer reservoir. Radiator coolant in the washer reservoir can severely reduce visibility when sprayed on the windshield.**

Follow these instructions when operating the engine in temperatures of 0°C (32°F) or lower:

- Make sure that the batteries are of sufficient size and are fully charged. Check other electrical components to make sure they are in optimum condition.
- Use a permanent-type engine coolant solution to protect the engine against damage from freezing.
- If your vehicle is equipped with a water-fuel separator, drain it daily. Fill the fuel tank at the end of daily operation to prevent condensation in the fuel system.
- Make sure you use proper cold weather engine oil and that it is at its proper level.

## Operation

---

- At temperatures of -20°C (4°F) or below, it is recommended that you use a crankcase-mounted coolant heater to improve cold engine starting.
- Consult your IC Bus, LLC dealer for information about special cold weather equipment and precautions if operating in arctic temperatures of -29°C (-20°F) or lower.

### ENGINE IDLING

#### CAUTION

**To prevent property damage, adhere to this Caution. Because diesel engines are highly efficient, they use very little fuel while idling. As a result, idling in cold weather will not heat the engine to its normal operating temperature. This in turn can cause a buildup of heavy deposits of carbon and rust on valve stems, causing them to stick. Sticking valves can cause significant valve train damage. The colder the ambient temperature, the more likely this will occur.**

The following cold weather idling guidelines must be followed:

- Avoid extended idling (beyond 10 minutes) whenever possible. To maximize engine and Diesel Particulate Filter (DPF) life, see Exhaust Diesel Particulate Filter Regeneration in this section for more information.
- Use a minimum 45 Cetane diesel fuel or utilize Cetane Index improvers from a reputable manufacturer.

- Maintain a minimum of 1,250 rpm idle by use of the hand throttle. Always make sure that parking brake is applied and transmission is in (P) Park before applying hand throttle.
- Maintain engine cooling system.
- Do not shut engine down after extended idling period. Drive the vehicle under load for several miles at normal operating temperatures to burn off any accumulated carbon and varnish.
- Consider use of engine block heaters, approved winter-fronts and / or radiator shutters where conditions warrant.

### WINTER FRONTS

Do not use winter fronts or other air-restrictive devices mounted in front of the radiator with a permanent opening with less than 3 m. sq. (120 in. sq.) directly in line with the fan hub. Air flow restriction can cause high exhaust temperatures, power loss, excessive fan usage, and reduce fuel economy.

### Hot Weather Operation

- Keep the engine cooling system filled with clean, permanent coolant solution to protect against damage from overheating.
- Keep external surface of the engine, radiator, charge air cooler and accessories clean to avoid dirt build up.
- Fill fuel tank at end of daily operation to prevent condensation in tank.



Above normal coolant temperature could be temporarily decreased by down shifting into the next lower gear. This increases engine RPMs, which increases coolant flow and air flow through the radiator.

**NOTE: If above normal operating temperatures persist, have vehicle serviced at first available opportunity.**

### Turning Off the Engine

Allow the engine to idle for three to five minutes before shutting it down. This allows the lubricating oil and coolant to carry heat away from the large iron components and the turbocharger, preventing engine damage from rising heat.

## Brakes

### Downhill Operation

Always descend hills with extreme care. Heed warning signs posted for any grade. Stop and check brakes for condition and adjustment at available pull off areas before starting a descent.

Observe the following precautions:

- Never coast downhill. Service brakes alone should not be used to control speed on major downgrades. Brakes fade from overuse.
- The downhill speed is controlled by removing your foot from the accelerator pedal and putting the transmission in a reduced gear. If the gear selection does not hold the desired speed without overuse of the brakes, an improper gear selection was made.

- Make a full stop. Let the brakes cool, then continue down the grade in a lower gear range.
- The common rule to follow in using the engine and transmission to control vehicle speed is to select the same gear going down the hill that would be required to ascend the hill.
- The service brakes should be used to supplement available vehicle retardation. When descending long grades requiring use of the brakes, short applications (five to ten seconds duration) should be made rather than long, lighter, continuous applications. This minimizes temperature brake fade.

### Hydraulic Brakes

*Using the Full Power Brake System*



**To prevent personal injury, or death, if the brake pressure warning indicator comes on while driving, be aware that your stopping distance may be significantly increased. Safely stop the vehicle as soon as possible and have the brake system repaired immediately as reduced braking capability could cause an accident.**



**To prevent property damage, personal injury, and / or death, always check and maintain brakes in proper condition and adjustment. Out-of-adjustment brakes could cause reduced braking ability.**

The Full Power Brake System incorporates standard braking, Antilock Braking (ABS), Automatic Traction Control (ATC), and the Powered Parking brake into one fully integrated hydraulic brake system. With the Full Power Brake system, braking energy is stored, similar to an air brake system, resulting in faster response times and shorter stopping distances. This is accomplished using motor / pump assemblies that pressurize the system by pumping brake fluid into accumulators. This is similar to the air compressor of an air brake system pressurizing the air tanks.

The system includes a master cylinder that provides the normal pedal feel and transfers the pedal force, via brake fluid, to the main components of the Full Power brake system.

**NOTE: The motor / pumps will run momentarily with the Ignition switch in the ON / RUN or OFF positions to maintain accumulator pressure. Therefore, whenever the brake pedal is depressed when with the Ignition switch in the OFF position, the motor / pumps may be heard.**

### *Split-System Feature*



**To prevent property damage, personal injury, and / or death, if part of the brake system fails, reduce speed and employ safe driving practices as stopping distance may increase under the failed condition or if only one section of the brake system is operating. Have brake system repaired immediately. Loss of braking capability could cause an accident.**

The system is divided into two separate but identical channels: the primary channel (controls front axle) and the secondary channel (controls rear axle). The master cylinder provides brake lines that are routed to the front and rear brake channels.

With the split brake system, the operator is ensured of reasonable brake control should one of the two channels fail. If one of the motor / pump related systems fail, the driver may not detect any difference in the feel of the pedal, but with a defect in the master cylinder circuit, the driver may experience a longer pedal stroke to attain desired stopping. With any system failure, one of the Instrument Panel Gauge Cluster warning indicators will turn on.

### *Warning Indicators*

Electronic Gauge cluster indicators identify brake system fault conditions. Certain faults may also result in cluster alarms. The following lists some of the common faults (See fault indicators in Instrumentation section):

**NOTE: Whenever a brake system warning indicator is lit, do not operate the vehicle until the faulty condition has been corrected.**

- **Brake Pressure.** ON STEADY when either front or rear brake system brake pressure is low. Once the vehicle is stopped and the parking brake is set, it will not release until brake system fault is repaired and the ignition switch is cycled Off and then On. FLASHES when both front and rear brake systems brake pressures are low. Once vehicle speed is reduced to below 40 km/h (25 mph), the engine will be limited to 40 km/h (25 mph) or less. When parking brake is set, it will not release until brake system fault is repaired and the ignition switch is cycled Off and then On.
- **Brake Fluid.** On steady when low fluid level is detected in Master Cylinder reservoir.
- **Service Parking Brake.** On steady when a fault is detected in parking brake circuit of the Full Power brake system.
- **Service Parking Brake (Power Parking Brake).** Flashes for 15-20 seconds along with repeating beeps, then comes on steady when a fault is detected in Parking Brake circuit.
- **Service Parking Brake (Air Operated Parking Brake).** On steady when a fault is detected in Parking Brake circuit of the Air operated parking brake system.

**NOTE: There may be a fault condition that results in more than one warning indicators being lit.**

*Power Parking Brake System*



**To prevent property damage, personal injury, and / or death, do not leave transmission in gear when parking your vehicle. Always use the parking brake. When parking on a grade, install wheel chocks and turn front wheels to keep the vehicle from rolling into the traveled portion of the roadway. Failure to follow these procedures could cause an unattended vehicle to move.**



**To prevent property damage, personal injury, and / or death, under no circumstances should the spring brake section of the spring and service brake chamber be disassembled. Disassembly will release a powerful spring.**

The purpose of the parking brake is to hold the vehicle in the parked position. It should NOT be used to brake the vehicle during normal driving. It may be used to assist in making an emergency stop in the event of service brake failure.

The Powered Parking Brake is controlled by the parking brake instrument panel switch. The switch has three positions: apply (out), neutral (center), and release (in). The switch is spring-loaded to return to the neutral (center) position after being pushed or pulled. There is no visual indication at the knob that the parking brake is applied or released. Always observe

## Operation

---

the gauge Instrument Panel Gauge Cluster PARKING BRAKE indicator to determine if the parking brake is applied or released.

The parking brake will be automatically applied when the ignition switch is moved to the OFF position and cannot be released until the ignition switch is turned to the ON position.

### To Manually Apply The Powered Parking Brake

1. Bring the vehicle to a complete stop, using your brake pedal.
2. Make sure that the engine is at low idle.
3. With your foot still firmly on brake pedal, place transmission in P (Park) or N (Neutral) position.
4. Pull and HOLD the parking brake control knob until the PARKING BRAKE indicator, in the Instrument Panel Gauge Cluster, illuminates. Then release the parking brake control knob (the knob will return to its normal resting position).

An **(Optional)** feature provides for the Parking Brake to automatically be applied (Auto-Apply) when the shifter is moved to the "PB" (Parking Brake) or "P" (Park) position.

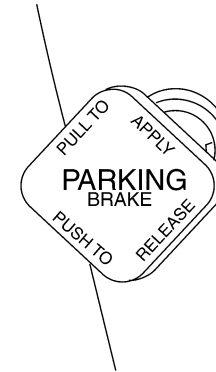

ICB100155

### Powered Parking Brake Control Knob

#### To Manually Release The Powered Parking Brake.

1. Turn ignition switch to the ON position,
2. Depress and hold the brake pedal, then,
3. Take transmission out of the P (Park) position and then,
4. Push and hold the Parking Brake control knob until the parking brake indicator goes out, then release.

**NOTE: If the transmission is not out of the Park position, the Parking Brake will not be released.**

**The transmission Shift / Wheelchair Lift Interlocks will also prevent release of the Parking brake until all conditions are satisfied (see Wheelchair interlocks in Automatic Transmission section).**

### Air Brakes



**To prevent property damage, personal injury, and / or death, to prevent loss of vehicle braking or control resulting in property damage, personal injury or death, never operate the vehicle when insufficient air pressure (less than 70 psi (483 kPa)) is indicated for either the primary or secondary air system, or if a low-pressure alarm is sounding and a warning indicator is illuminated. The volume of air required to stop the vehicle may be greater than that available. Have the brake system checked and repaired before returning the vehicle to service.**

All air brake equipped vehicles have a split brake system. A split system provides a way to stop the vehicle if a failure occurs in either the primary or secondary brake system. If air pressure is lost in one system, the remaining system continues to provide braking action.

Even though there is braking capability for emergency stopping, do not operate the vehicle when a failure is indicated, because there may be no way of replenishing air pressure.

If vehicle has been parked for an extended period in cold weather, always check to be sure all wheels are rolling free (brakes are not frozen) when starting out. Always clean accumulated ice and snow from brake linkage.

If air pressure in either section of the split air brake system is reduced to 57psi (393 kPa) the warning buzzer will sound and a

red indicator on the Instrument Panel Gauge Cluster glows. In addition, the air gauge(s) will indicate low air pressure in at least one of the split systems.

The warning buzzer and red indicator automatically shut off when the air pressure in both systems is sufficient [approximately 70 psi (483 kPa)] to operate the vehicle.

If the red indicator and buzzer do not shut off after startup, check the air pressure gauge(s) and see if one or more sections of the split system has low air pressure.

If the red indicator, buzzer, and gauge indicate a loss of pressure while driving, the vehicle will still have some braking capability. Either one-half of the split system or the spring brake system braking capability is retained. However, the distance required to stop the vehicle will be increased.

#### *Air Disc Brakes (0004JBZ, 0004JCC, 0004WEY, 0004WEZ)*

The air disc brake system encompasses a floating caliper design that is activated when air pressure is introduced into the system.

The air disc brake system works by converting air pressure into braking force. When braking is applied, air will enter the brake chamber, applying pressure to the diaphragm. The pressure created activates the system causing the brake pads to contact the rotor. When braking is released, the air pressure in the brake chamber is released, exhausting the pressure on the diaphragm, causing the brake pads to return to their neutral / non-braked position.

## Operation

---

### *Using Air Brakes*



**To prevent property damage, personal injury, and / or death, always check and maintain brakes in proper condition and adjustment. Out-of-adjustment brakes could cause reduced braking ability.**

Do not apply and release (pump) the brakes rapidly. This is an inefficient way of slowing or stopping a vehicle and inefficient use of air pressure. This also reduces the ability of the ABS system to function properly.

### *Using the Air Parking Brake*



**To prevent property damage, personal injury, and / or death, before starting the engine, the parking brake control knob must be in the applied (pulled) position. Failure to do so could allow the vehicle to roll.**

The purpose of the parking brake is to hold the vehicle in the parked position. It should NOT be used to brake the vehicle during normal driving. It may be used to assist in making an emergency stop in the event of service brake failure.

**Parking Brake / Wheelchair Lift (Optional) Interlock.** On vehicles equipped with an Optional Wheelchair Lift, power will

not be supplied to the wheelchair lift mechanism unless the parking brake is applied.

**NOTE: On vehicles equipped with Optional Wheelchair Lift, the parking brake cannot be released until the Wheelchair Lift is completely stowed.**

**NOTE: For a complete description of these interlocks, see the Parking Brake / Wheelchair Lift (Optional) Interlock procedures in the Hydraulic Brake section.**

### **To engage Air Parking Brake**

1. Bring the vehicle to a complete stop, using your brake pedal.
2. Make sure the engine is at low idle.
3. With your foot still firmly on brake pedal, place transmission in neutral position.
4. Pull the parking brake control knob to apply the parking brake.

### **To release Air Parking Brake**

1. Have the engine running and your foot on the service brake pedal.
2. Push in the control knob.
3. Wait until system pressure has reached 70 psi.

**NOTE: DO NOT operate vehicle until system pressure has reached 70 psi.**

**NOTE:** To release the parking brake on vehicles with the **Optional Wheelchair Lift**, the **Lift must be completely retracted and stowed.**

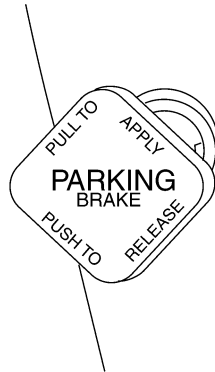

ICB100155

## Air Parking Brake Control Knob

## Air Brake Gauge



## Air Brake Gauge

The air operated parking brake has an air gauge and warning buzzer. When pressure in the parking brake air reservoir has been reduced to about 393 kPa (57 psi ), the buzzer sounds.

A loss of pressure in the control circuit prevents normal operation of the parking brake.

### CAUTION

**To prevent property / vehicle damage, if air system pressure falls below 70 psi (483 kPa), pull off the roadway, apply the parking brake and correct the low pressure condition.**

If air pressure is reduced to approximately 276 kPa (40 psi) in both the primary and secondary systems, the parking brakes will automatically apply.

### *Parking Brake Indicator Light*

The parking brake indicator is illuminated when the Parking Brake is applied. During engine cranking period the parking brake indicator should illuminate. This indicator goes out after the engine is started if the parking brake is not applied. If the parking brake is applied, this indicator remains on after engine has started. If the indicator does not illuminate during cranking period, the light bulb may be defective.



ICB100022

## Operation

---

### Parking Brake / Wheelchair Lift Interlock and Alarm

On vehicles equipped with an optional Wheelchair Lift, the following will describe the optional Parking Brake / Wheelchair Lift interlock and Parking Brake / Wheelchair lift alarm. Read and understand these paragraphs and the Wheelchair lift manufacturer's Operator Manual before operating the Wheelchair lift.

Power will not be supplied to the wheelchair lift mechanism unless all of the following steps have been performed.

#### *Wheelchair Lift Extension Operation*

1. Ensure that the ignition switch is in the ON or ACCESSORY position.
2. Place transmission shift lever in "PB" (Parking Brake), "P" (Park), or N (Neutral) position.
3. **For Air Brakes**, pull Parking Brake knob (Park indicator on Instrument Panel Gauge Cluster will turn on).
4. **For Hydraulic brake**, pull and hold the Parking Brake knob to apply Parking Brake.

An **(Optional)** feature provides for the Hydraulic Parking Brake to automatically be applied (Auto-Apply) when the transmission shift lever is moved to the "PB" Parking Brake or "P" Park position.

5. Open the Wheelchair Lift door.

The Wheelchair Lift can now be operated (according to the manufacturer's Operators Manual instructions). The LIFT

DOOR Instrument Panel Gauge Cluster indicator turned On and will remain On as long as the wheelchair lift door is opened.

#### *Parking Brake / Wheelchair Lift Interlock--Retracting and Stowing Operation*

The vehicle cannot be moved (the Parking Brake cannot be released), until the following operations are performed.

1. Turn ignition on.
2. Retract and stow the Wheelchair Lift. The LIFT DOOR Instrument Panel Gauge Cluster indicator will be turned Off.
3. Close the lift door.
4. Depress the service brake and press and hold the button on the gearshift lever handle and select "R" (Reverse) or "D" (Drive) position.
5. **For Air Brakes**, push in on the Parking Brake knob (Park indicator on Instrument Panel Gauge Cluster will turn off).
6. **For Hydraulic Brakes**, push and hold the Parking Brake knob until the Park indicator turns off.
7. Lift foot from the brake pedal, and then slowly press the accelerator pedal.

#### *Parking Brake / Wheelchair Lift (Optional) Alarm*

- The Instrument Panel Gauge Cluster alarm will beep continuously if the Wheelchair lift door is extended **AND**
- The Parking Brake is released.



**NOTE:** When either the Powered Parking Brake is applied, or the Wheelchair lift door is closed, the Instrument Panel Gauge Cluster alarm will immediately stop beeping.

**Antilock Braking System (ABS)**



To prevent property damage, personal injury, and / or death, Antilock Brake System(s) (ABS) are designed to enhance overall vehicle safety when a vehicle is driven within its safe operating limits. ABS cannot compensate for a vehicle that is being driven beyond the physical limits of control. Drivers operating an ABS-equipped vehicle should employ safe driving practices and assume no additional driving risks.



To prevent property damage, personal injury, and / or death, do not rely on the Antilock Brake System (ABS) to interrupt vehicle engine brake on slippery road surfaces. Turn these devices off during hazardous driving conditions. Failure to follow this warning may cause wheel slippage and / or loss of vehicle control.



To prevent property damage, personal injury, and / or death, if the Antilock Brake System (ABS) warning indicator comes on, have the ABS repaired immediately as stopping distances may increase under certain braking conditions. Take every precaution to prevent wheel lockup, which could result in loss of vehicle control.



To prevent damage to the electrical system or ABS components, when welding on an ABS-equipped vehicle, disconnect the power connector from the Engine Control Module (ECM). Failure to heed this caution may result in vehicle and / or engine component damage.

The ABS system is a mandated system used with the Hydraulic and Air Brake systems. The antilock brake system electronically monitors vehicle wheel speed, and only engages when wheel lock is imminent. The standard brake system controls normal braking when the ABS is not engaged. ABS requires few changes in driving practices. For the best stopping performance, press, do not pump the brake pedal until the vehicle slows to desired speed or stops. The ABS system cannot provide any better braking and steering capability than the available road traction permits. If the road is slippery, it takes longer to stop than on a dry road. Steering maneuverability is similarly limited. Vehicle speed must be reduced to compensate for the extended time and distance required to stop or slow the vehicle

## Operation

---

on slippery roads. ABS prevents lockup of controlled wheels if you over brake for existing road conditions.

The wheel hubs carry exciter rings used by the axle mounted sensors to transmit wheel speed information to the ABS electronic control unit located on the chassis frame. The control unit monitors and compares all wheel speed inputs to determine if any wheel(s) are about to lock. If wheel lockup is about to occur, the control unit commands the appropriate modulator valve to adjust pressure delivery to prevent wheel lockup.

If over-braking causes wheel lockup on the rear drive axles while retarding devices are in operation, the ABS will interrupt and disable the retarder until the lockup situation has stopped.

The ABS is equipped with a warning indicator located in the vehicle's Instrument Panel Gauge Cluster. Each time the ignition is turned on the ABS performs a self check. The ABS warning indicator will illuminate and if the ABS passes the self check, the indicator will turn off a few seconds after the ignition is turned on. ABS fault codes will be electronically stored in the ABS.

### Antilock Driving Tips

- Use controlled, even pressure to stop the vehicle, being careful not to skid. Most effective stopping will be achieved in this situation.
  - If the vehicle begins to skid, maintain even pressure on the brake pedal. The ABS controller will rapidly cycle the brakes on the skidding wheel(s), while maintaining even pressure on the non-skidding wheels.
  - While maintaining even pressure on the brake pedal, steer around any hazardous objects in your path.
- Attempt to steer clear of traffic, pedestrians or other obstacles while you are in an emergency braking situation. The antilock brake system will allow you to steer the vehicle during braking while it comes to a full stop. ABS is not an excuse to take unnecessary risks. Always drive carefully and stay a safe distance away from the vehicle in front of you.
  - Do not pump the brake pedal during a skid unless the ABS system is not functioning.

### ABS Self-Check

**NOTE: If an antilock fault develops, standard brake system operation is maintained. The brake system is still operational, but the antilock system does not operate to prevent wheel lockup if you over apply the brakes for existing conditions.**

**NOTE: If the ABS indicator stays illuminated or continues to flash, have the system serviced immediately.**

A yellow warning indicator on the instrument panel indicates the status of the ABS. Each time the ignition is turned on the indicator comes on and the system goes through an ABS self-check sequence. If the system is working normally when the ignition is turned ON, the ABS indicator comes on then flashes twice, and finally the ABS indicator remains on for several seconds before going out.

### **Pedal Adjustment**

Adjustment of brake pedal free travel should not be necessary. In the event adjustment is necessary, it is extremely important that the work be properly performed. Allow only qualified technicians to perform this operation.

### **Traction Control (If Equipped)**



**To prevent property damage, personal injury, and / or death, drivers operating a Traction Control equipped vehicle should employ safe driving practices and assume no additional driving risks. Traction Control systems are designed to enhance overall vehicle safety when a vehicle is driven within its safe operating limits. Traction Control cannot compensate for a vehicle which is being driven beyond the physical limits of control.**

Your vehicle may be equipped with an optional Traction Control system which helps you maintain the stability and steerability

of your vehicle, especially on snow or ice-covered roads and gravel roads. It reduces engine power and / or selectively applies the rear brakes. The system allows your vehicle to make better use of available traction in these conditions by also limiting the engine RPM when you push further on the accelerator, which limits wheel spin. The TRAC CTRL indicator in the Instrument Panel Gauge Cluster will illuminate during this Traction Control event. The TRAC CTRL indicator will also illuminate if the system is malfunctioning.

**TRAC  
CTRL**

ICB100018

**NOTE: The traction control braking (ATC action) to limit wheel spin does not occur at vehicle speeds above approximately 50 km/h (31 mph). Therefore, at speeds above 50 km/h (31 mph), all ATC events are controlled only by Engine Power Limiting.**

### The Traction Control switch for Hydraulic Brake equipped vehicles.

With the Traction Control switch in the TRAC CTRL position, the system operates as described above. The MUD / SNOW position of the Traction Control switch provides modified system performance for deep mud or snow conditions. If the optional Traction Control switch is in this position, the Instrument Panel Gauge Cluster TRAC CTRL indicator will flash.



### The Traction Control switch for Air Brake equipped vehicles.

If the system is enabled (Traction Control switch in the TRAC ENAB position), the TRAC CTRL indicator in the Instrument Panel Gauge Cluster will flash during a Traction Control event and the engine may not increase RPMs when you push further on the accelerator. If the Traction Control switch is in the DISAB position, the Traction Control system is disabled.

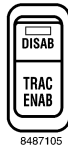

## International® Ride Optimized Suspension (IROS) (If Equipped)

### CAUTION

To prevent property damage, do not operate a vehicle without air in the suspension springs. Operating the vehicle without air in the air suspension springs will damage the suspension, degrade ride performance and may cause transmission damage.

The suspension system automatically adjusts to different loads to maintain a constant frame height. The system allows for ease of vehicle loading and provides improved vehicle ride and increased driver comfort. The system is completely automatic.

## Automatic Transmission Operation

### Standard Allison 1000 PTS Transmission



To prevent property damage, personal injury, and / or death, check to see that area behind vehicle is clear of people, animals, and objects before backing up. Use a spotter whenever possible and always keep that person in sight. If so desired, backup alarms are available through your IC Bus, LLC dealer. However, they are never a substitute for the above procedures.



**WARNING**

To prevent property damage, personal injury, and / or death, hold the brake pedal down while you move the gearshift from position to position to prevent unexpected vehicle movement.

**NOTE:** For complete transmission operation, refer also to separate Allison Transmission Operator's Manual.

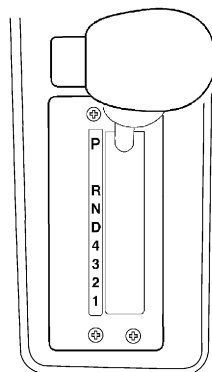

3813041

**Allison Transmission Mechanical Lever Shifters**

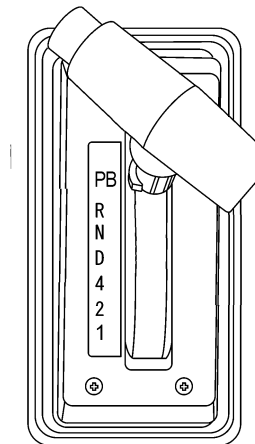

1. Apply the service brake and press and hold the button on the gearshift lever handle.
2. With the brake still applied, continue to hold the gearshift lever button while moving the gearshift lever to Reverse (R) or Drive (D) position, and then release the button.
3. **For Air Brakes**, push in on the Parking Brake knob (Park indicator on Instrument Panel Gauge Cluster will turn off).
4. **For Hydraulic Brakes**, push and hold the Parking Brake knob, (Park indicator on Instrument Panel Gauge Cluster will turn off).

## Operation

---

5. Lift foot from the brake pedal, and then slowly press the accelerator pedal.

### Allison Generation IV T-Bar Gearshift Control



**To prevent property damage, personal injury, and / or death, hold the brake pedal down while you move the gearshift from position to position to prevent unexpected vehicle movement.**

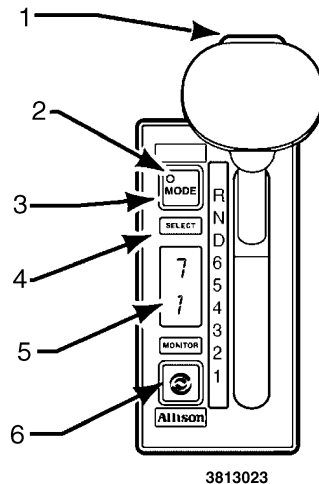

1. Hold Override Button
2. Mode Indicator (LED)
3. Mode Button
4. Mode ID
5. Digital Display
6. Display Mode Diagnostic Button

To shift out of “R” or between any other gear range, first push and hold the gearshift lever button while moving the selector control to the desired gear range.

When the vehicle is started, the transmissions are designed to operate in the standard performance mode. Pressing the Mode button on the shift tower will switch the transmission to Economy mode and illuminate Mode ON in the shift tower display. Economy mode provides operation at a lower engine RPM while maintaining adequate performance.

If the engine speed is above idle when a gear is selected with the shift tower, the vehicle will not launch. To move the vehicle, the shift tower must be moved to re-select a gear after the engine comes down to idle.

For further information on the Allison transmission, refer to the separate Allison vocational transmission model Operator Manual.

## Allison Generation IV Push-Button Shift Selector

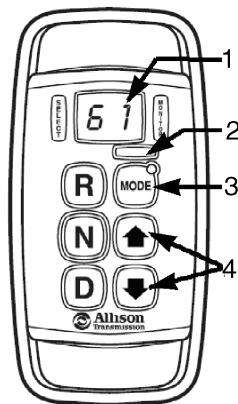

3813024

1. Digital Display
2. Mode ID
3. Mode Button
4. Range Selector Buttons

To shift the transmission into “R” (Reverse) or D (Drive), press the brake pedal, then press “R” or “D”, then release the brake pedal.

To select a lower range when in “D” (Drive), press the down-arrow button.

To select a higher range when locked in a lower range, press the up-arrow button.

To place the transmission in “N” (Neutral), press “N”.

### Parking the Vehicle.

1. Use your brake pedal to bring the vehicle to a complete stop.
2. Make sure the engine is at low idle.
3. Move the transmission shifter to the PB (Parking Brake), P (Park) or N (Neutral). With the Push Button shifter, press the N (Neutral) button.
4. **For Air Brakes**, pull the Parking Brake knob (Park indicator on Instrument Panel Gauge Cluster will turn on).
5. **For Hydraulic brake**, pull and hold the Parking Brake knob to apply Parking Brake.

An **(Optional)** feature provides for the Hydraulic Parking Brake to be automatically applied (Auto-Apply) when the transmission shift lever is moved to the “PB” Parking Brake or “P” Park position.

6. Slowly remove your foot from brake pedal and make sure that the parking brake is properly engaged (The Instrument Panel Gauge Cluster PARK indicator will turn On).

### Parking the Bus With Transmission Shift / Wheelchair Lift Interlocks



**To prevent property damage, personal injury, and / or death, always set the parking brake when operating the wheelchair lift, or unexpected and sudden vehicle movement may occur.**

Read and understand these paragraphs, along with the Wheelchair lift manufacturer's Operator Manual before operating the Wheelchair lift. On vehicles equipped with an optional Wheelchair Lift, the optional Transmission / Wheelchair Lift Interlock provides that power will not be supplied to the wheelchair lift mechanism, and therefore, the Wheelchair Lift cannot be operated until the previous steps have been completed.

#### *Wheelchair Lift Extension Operation*

After the bus has been safely parked (see previous steps):

1. Open the Wheelchair Lift door (LIFT DOOR Instrument Panel Gauge Cluster indicator should be turned on).
2. Extend the Wheelchair Lift (according to the manufacturer's Operator Manual instructions). The LIFT DOOR Instrument Panel Gauge Cluster indicator turned On and will remain On as long as the wheelchair lift door is opened.

### Starting Bus in Motion

To start the bus in motion:

1. Depress the brake pedal and press and hold the button on the gearshift lever handle and move the gearshift lever from Park (P) to Reverse (R) or Drive (D) position, and then release the button.
2. Release the Parking Brake (push and release the Parking Brake knob), lift foot from service brake, and then slowly press the accelerator pedal (The Instrument Panel Gauge Cluster PARK indicator should be turned off).

### Starting Bus in Motion With Transmission Shift / Wheelchair Lift Interlocks

Read and understand the Wheelchair lift manufacturer's Operator Manual before operating the Wheelchair lift.

On vehicles equipped with an optional Wheelchair Lift, the optional Transmission / Wheelchair Lift Interlock will prevent shifting out of the "PB" Parking Brake, or "P" Park position, until the Wheelchair Lift door is closed. This will prevent the vehicle from being moved while the Wheelchair Lift is still extended. For a description of the Wheelchair Lift retraction and stowing operation, go to the Passenger Control section.

### Retracting and Stowing Operation

After using the Wheelchair Lift, to load passengers, before you can start the bus in motion, (shifting the gearshift lever out of the "P" [Park] position), retract and stow the Wheelchair lift and then



close the lift door (LIFT DOOR gauge luster indicator should be turned off).

When the Wheelchair Lift has been safely stowed (according to the Wheelchair lift manufacturer's Operator Manual instructions), the bus can be safely moved as follows:

- Depress the brake pedal and press and hold the button on the gearshift lever handle and move the gearshift lever from Park (P) to Reverse (R) or Drive (D) position, and then release the button.
- Release the Parking Brake (push and release the Parking Brake knob), lift foot from service brake, and then slowly press the accelerator pedal (The Instrument Panel Gauge Cluster PARK indicator should be turned off).

### Backup Alarms

This bus may be equipped with one of two backup alarms options to warn anyone standing behind the vehicle that it is in the process of backing up. The backup alarm is activated by:

**Reverse gear Alarm Option.** With foot on brake pedal, shift the transmission into R (Reverse). **The backup alarm will sound as long as the transmission shift selector is in the R (Reverse) position.**

**Roll Back Alarm Option.** Release the parking brake and then take your foot off the service brake pedal, allowing the bus to drift backward. **The backup alarm will sound as soon as the bus begins to roll backward.**

**NOTE: This optional backup alarm is activated every time the vehicle moves backwards, in any gear, with the ignition On or Off.**

### Economy Mode

The Economy mode provides a transmission shift schedule for improved fuel economy. To activate this mode, switch the ECON / ON switch, on the right switch panel, to the ON position. When in the ON position the switch indicator will be turned on.

### Automatic Transmission Operating Temperatures

Your vehicle may be equipped with a warning indicator or gauge that will indicate high transmission fluid temperatures.

The sump / fluid reservoir temperatures of the Allison Transmissions should not exceed 120°C (250°F).



## SECTION 10 — ROADSIDE EMERGENCIES

### Hazard Warning Switch



To prevent property damage, personal injury, and / or death, if engine shutdown occurs, if possible, make sure that vehicle is safely off the roadway, turn on 4-way emergency flashers, and properly place warning devices.

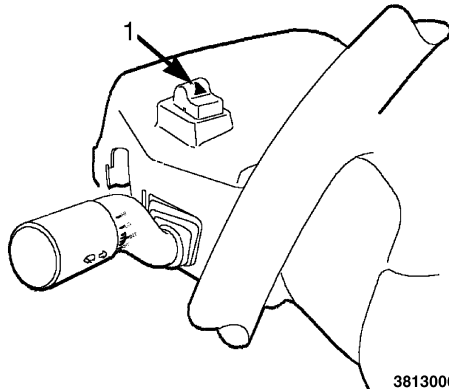

3813006

Use the hazard warning light switch in an emergency to warn traffic of vehicle breakdown, approaching danger, the vehicle is in tow, or is operating at a reduced speed.

Press the button to activate all hazard flashers simultaneously.

Press the button again to turn off the flashers.

## Roadside Emergencies

---

### Emergency Equipment (Recommended On-Board)

#### Fire Extinguisher

Inspect the fire extinguisher monthly to make sure it has a sufficient charge. Look at the gauge located at the top of the extinguisher to verify proper charge.



ICB100515

#### First Aid Kit



ICB100512

Make sure to keep the first aid kit completely stocked and ready for use at all times by replacing any items used.

### Body Fluid Cleanup Kit



ICB100513

Use this whenever any type of body fluid comes in contact with the bus. When items are used, they should be immediately replaced.

### Reflective Triangle

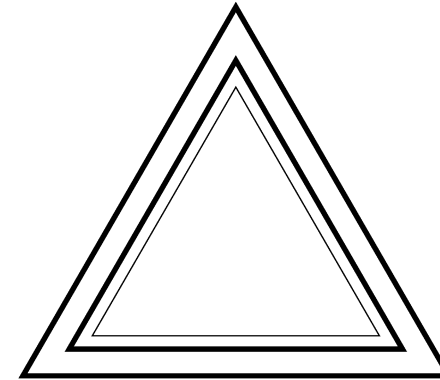

ICB100514

Use the triangle whenever the bus is pulled over to the side of the road. The reflective triangle kit is usually located behind the driver's seat. After opening the kit, unfold the triangle and make sure it locks in place.

# Roadside Emergencies

## Fuse / Circuit Breaker Charts

### Chassis Fuse / Circuit Breaker Chart

The following fuse illustrations represent typical fuse panel layouts. The actual vehicle fuse panels will vary depending on the vehicle options.

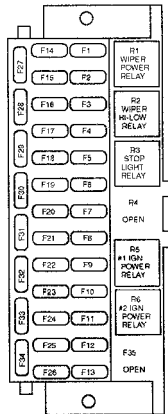

Table 9

Location	Size	Description
F1	10 Amps	Air Solenoid Power Relay Battery Feed
F2	15 Amps	Instrument Panel Gauge Cluster Battery Feed
F3	5 Amps *	Hydraulic Brake Switch Battery Feed
F4	10 Amps	Ammeter / Crossing Gate Battery Feed
F5	10 Amps	Stop Light Relay Battery Feed
F6	—	Not Used
F7	10 Amps	Key Switch Battery Feed
F8	30 Amps	Ignition Relay (R5) Battery Feed
F9	10 Amps	Diagnostic Connector Battery Feed
F10	30 Amps	Ignition Relay (R6) Battery Feed
F11	5 Amps*	Body Builder Accessory Feed
F12	5 Amps*	Hydraulic Brake Accessory Feed
F13	5 Amps*	System Controller / Switch Pack Accessory Feed
F14	5 Amps*	Body Builder Ignition Feed
F15	10 Amps	Crossing Gate or Fan Clutch Relay Ignition Feed

Location	Size	Description
F16	10 Amps	System Controller Ignition Feed
F17	5 Amps*	Engine Electronics Ignition Feed
F18	5 Amps*	Accelerator Pedal Ignition Feed
F19	5 Amps*	Auto Drain Valve Relay Ignition Feed
F20	10 Amps	Backup Light Ignition Feed
F21	10 Amps	Transmission Control Module Ignition Feed
F22	5 Amps*	LCT Shifter / Econ Switch Ignition Feed / Instrument Panel Gauge Cluster Switch
F23	10 Amps	Fuel Heater / Air Dryer / Drain Valve Ignition Feed
F24	5 Amps*	Instrument Panel Gauge Cluster Ignition Feed
F25	5 Amps*	Air Brake Module Ignition Feed
F26	5 Amps*	Panel Light System
F27	10 Amps	Brake Monitor Ignition Feed
F28	5 Amps*	Air Parking Brake Interlock Solenoid Ignition Feed
F29	5 Amps*	Change Transmission Filter Ignition Feed

Location	Size	Description
F30	—	Not used
F31	—	Not used
F32	—	Not used
F33	15 Amps	Fog Light Battery Feed
F34	10 Amps	Windshield Washer Pump Ignition Feed
F35	—	Not used
<p><b>NOTE: Locations marked with a * must use fuse only.</b></p> <p><b>NOTE: Descriptions in Parentheses () indicate fuses used in chassis with hydraulic brakes.</b></p>		

**Table 10 Fuse Description Chart**

Amps	Color
5	Tan
10	Red
15	Light Blue
20	Yellow
25	Clear
30	Light Green

# Roadside Emergencies

## Body Fuse / Circuit Breaker Panel

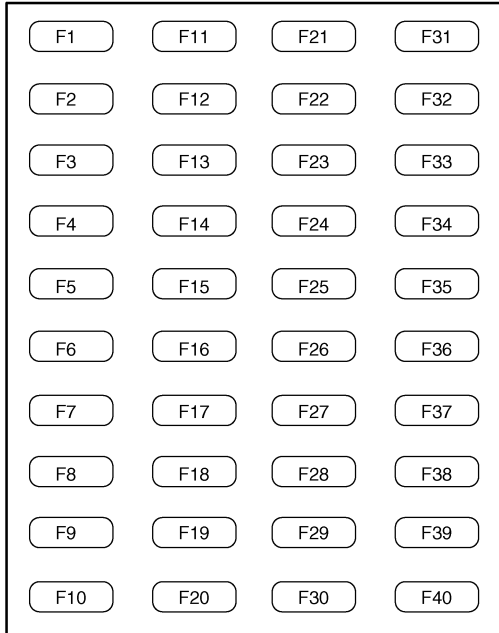

ICB200000

Table 11

Location	Size	Description
F1	—	Spare
F2	—	Spare
<b>F3</b>	<b>10 Amps</b>	<b>Left Side Dome Lights</b>
F4	7.5 Amps	Motorized Rear View Mirrors
F5	—	Spare
F6	15 Amps	Booster Pump
<b>F7</b>	<b>10 Amps</b>	<b>Right Side Dome Lights</b>
F8	7.5 Amps	Strobe Lights
F9	7.5 Amps	Light Monitor
F10	15 Amps	Destination Signs
F11	7.5 Amps	Air Horn
F12	20 Amps	Air Compressor
F13	—	Spare
F14	7.5 Amps	Heated X-View and / or Rear View Mirrors
F15	10 Amps	Camera
F16	7.5 Amps	Activity Light
F17	25 Amps	Bottom Step Heater
F18	7.5 Amps	Heater Wiper Blades
F19	—	Spare
<b>F20</b>	<b>15 Amps</b>	<b>Ignition / Accessory Power</b>



Location	Size	Description
F21	15 Amps	DC Power Outlet
<b>F22</b>	<b>7.5 Amps</b>	<b>Stop Arm</b>
F23	7.5 Amps	Lift Solenoid Power
F24	10 Amps	Optional Location for Left Side Dome Light
<b>F25</b>	<b>10 Amps</b>	<b>Clearance Lights</b>
F26	7.5 Amps	Lift Lights
F27	10 Amps	Optional Location for Right Side Dome Lights
F28	7.5 Amps 7.5 Amps	Separate Switch Illumination Dimmer Radio Memory
F29	10 Amps	Reverse Motion Sensor
F30	10 Amps	Vandal Lock (Air) or Electric Door
<b>F31</b>	<b>30 Amps</b>	<b>Driver Heater / Defrost Fan (High-Speed)</b>
F32	7.5 Amps	Radio Power
F33	25 Amps	Left Midship Heater Fan
F34	25 Amps	Left Rear Heater Fan
F35	25 Amps	Right Midship Heater Fan
<b>F36</b>	<b>30 Amps</b>	<b>Driver Heater / Defrost Fan (Low-Speed)</b>

Location	Size	Description
F37	20 Amps	Stepwell Heater Fan
F38	7.5 Amps	Left Defog Fan
F39	7.5 Amps	Center Defog Fan or Right Defog Fan
F40	15 Amps 25 Amps	Power Vents Right Rear Heater Fan
<ol style="list-style-type: none"> <li>1. Bold text represents standard bus features.</li> <li>2. Due to the many variations in customer options, this fuse chart should be used for reference only. Fuse locations may change due to many possible option combinations.</li> </ol>		

**Table 12 Fuse Description Chart**

Amps	Color
5	Tan
10	Red
15	Light Blue
20	Yellow
25	Clear
30	Light Green

# Roadside Emergencies

## Typical Interior Fuse Panel Layout

Fuse Panel Layout, Sheet 1

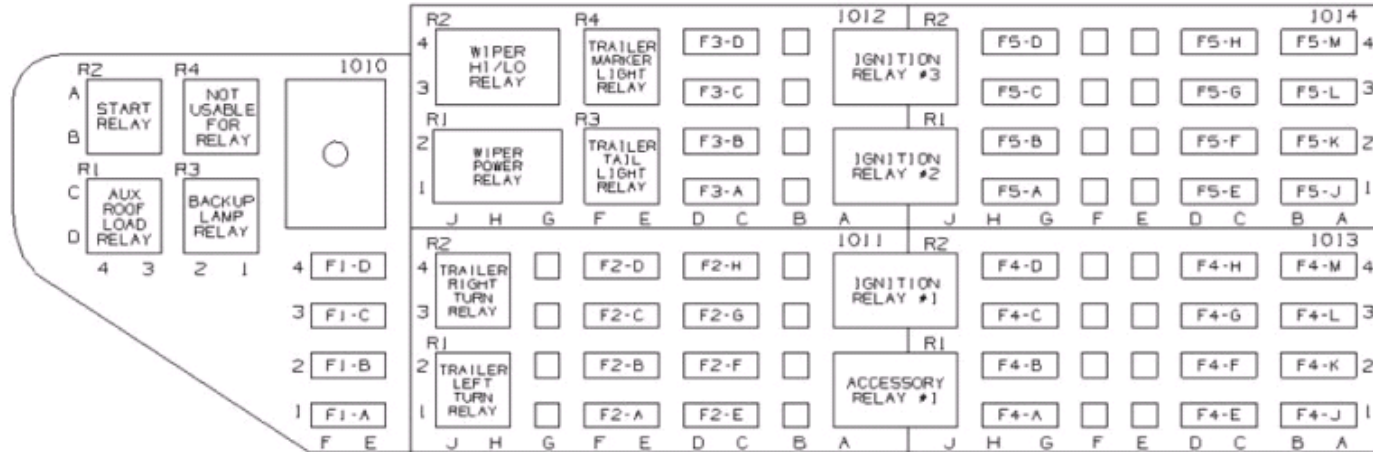

Fuse Panel Layout, Sheet 2

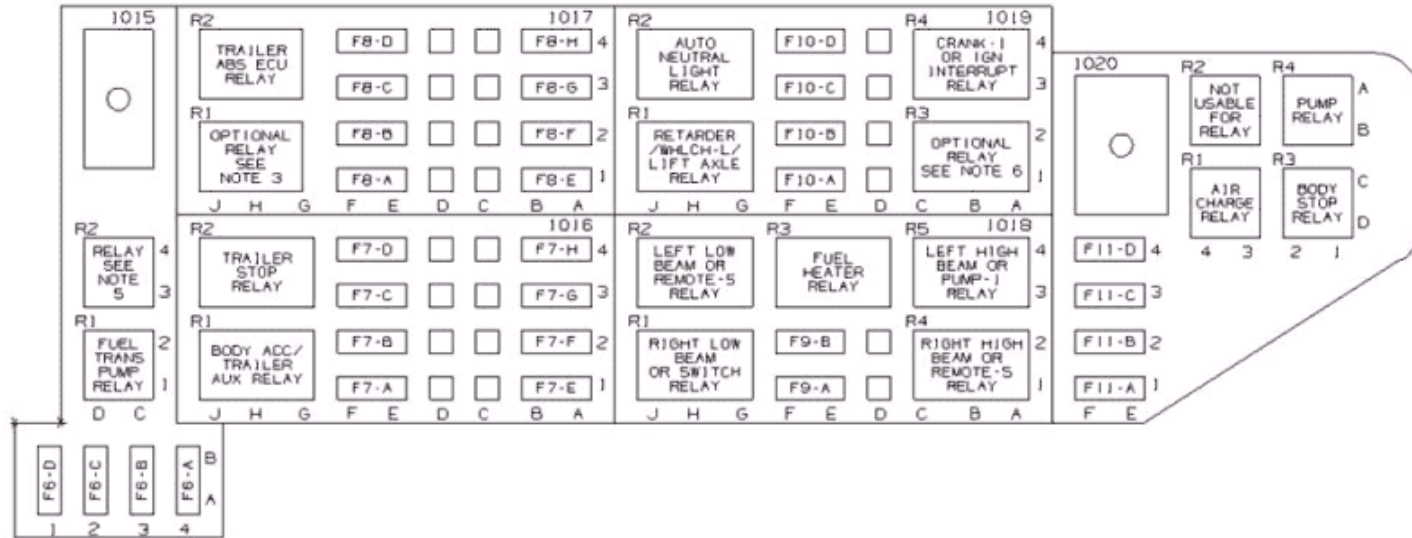

## Roadside Emergencies

### Fuse Panel Layout, Sheet 3

LOCATION	AMP		STD/OPT	DESCRIPTION	LOCATION	AMP		STD/OPT	DESCRIPTION
F1-A	5	IGN K	OPT	ENGINE CONTROL UNIT (16/VB)	F4-C	10	IGN	OPT	TRANSMISSION CONTROL UNIT
F1-B	5	BTRY	STD	CAB HVAC CONTROL	F4-D	10	IGN	OPT	ENGINE CONTROL UNIT
F1-C	5	IGN K	OPT	AIR ABS / HYD FPB - HBCU	F4-E	30	BTRY	OPT	POWER WINDOW/DOOR - PASSENGER
F1-D	5	STOP	OPT	DRAIN VALVE (HALDEX) AUTOMATIC	F4-F	10	ACC	STD	CB RADIO / ENTERTAINMENT RADIO
F2-A	15	BTRY	OPT	TRAILER LEFT TURN	F4-G	10	IGN	OPT	OPTIONAL WARNING LIGHTS
F2-B	15	BTRY	OPT	CIGAR LIGHTER	F4-H	10	IGN	STD	WINDSHIELD WASHER PUMP
F2-C	15	BTRY	OPT	TRAILER RIGHT TURN	F4-J	5	ACC K	STD	BODY CONTROLLER
F2-D	10	BTRY	STD	CAB DOME / MAP LIGHTS	F4-K	10	ACC	STD	SWITCH PACK
F2-E	10	BTRY	STD	ENTERTAINMENT RADIO MEMORY	F4-L	10	IGN	STD	CLUSTER / CAB HVAC CONTROLLER
F2-F	10	BTRY	OPT	SATELLITE COMM / COMPUTER PREWIRE	F4-M	10	IGN	STD	BODY CONTROLLER / CAB HVAC LPM
F2-G	15	BTRY	STD	INSTRUMENT CLUSTER	F5-A	10	IGN	OPT	AIR PARK BRAKE
F2-H	10	BTRY	OPT	AMMETER MODULE	F5-B	10	IGN	OPT	INVERTER / AUX POWER SOURCE
F3-A	10	BTRY	STD	KEY SWITCH / DIAGNOSTIC	F5-C	5	---	OPT	ACCELERATOR (16/VB)
F3-B	20	BTRY	OPT	TRAILER / BODY TAIL LIGHT	F5-D	10	IGN	OPT	SNOW VALVE / RETARDER / COLLSN WARN
F3-C	20	BTRY	OPT	AUXILIARY POWER SOURCES	F5-E	10	IGN	OPT	CLUTCH / START ENABLE
F3-D	20	BTRY	OPT	TRAILER / BODY MARKER LIGHT	F5-F	10	IGN	OPT	DISPLAY SYSTEMS / BACKUP CAMERA
F4-A	30	BTRY	OPT	POWER WINDOW/DOOR - DRIVER	F5-G	10	IGN	OPT	OWNER OPERATOR
F4-B	10	ACC	OPT	POWER MIRRORS	F5-H	10	IGN	OPT	COMPASS MODULE

## Fuse Panel Layout, Sheet 4

LOCATION	AMP		STD/OPT	DESCRIPTION	LOCATION	AMP		STD/OPT	DESCRIPTION
F5-J	10	IGN	OPT	SAT COMM / AUTO NEUTRAL	F8-C	10	BTRY	OPT	REMOTE POWER UNIT
F5-K	20	IGN	OPT	AIR DRYER / HEATED DRAIN VALVE	F8-D	30	BTRY	OPT	TRAILER AIR ABS / ETB AUXILIARY
F5-L	10	IGN	OPT	1BBE EIM	F8-E	20	BTRY	OPT	1BBE / CAT ECM
F5-M	10	JGN	STD	BACK-UP LIGHTS	F8-F	NOTE 2	BTRY	OPT	TRANSMISSION CONTROL UNIT
F6-A	30	BTRY	STD	CAB HVAC BLOWER MOTOR	F8-G	30	BTRY	OPT	ELECTRIC TRAILER BRAKES
F6-B	20	BTRY	OPT	AUXILIARY ROOF LOAD	F8-H	NOTE 4	BTRY	OPT	ENGINE CONTROL UNIT (BIG BORE)
F6-C	10	BTRY	OPT	FUEL TRANSFER PUMP	F9-A	5	IGN	OPT	2 WAY RADIO
F6-D	20/30	BTRY	OPT	FUEL HEATER	F9-B	5	ACC	OPT	AUX ROOF LOAD / WHEEL CHAIR LIFT
F7-A	30	BTRY	OPT	POWER WINDOW/DOOR - LEFT REAR	F10-A	5/10	---	OPT	FAN SOLENOID (16/VB) / 1BBE HC1
F7-B	NOTE 1	BTRY	OPT	BODY ACCESSORY / TRAILER AUXILIARY	F10-B	15	STOP	OPT	ELECTRIC TRAILER BRAKES
F7-C	15	BTRY	OPT	OWNER OPERATOR	F10-C	20	BTRY	OPT	BODY STOP
F7-D	30	BTRY	OPT	TRAILER STOP	F10-D	20	BTRY	OPT	ENGINE CONTROL UNIT (CAT, 1BBE)
F7-E	10	BTRY	OPT	DISPLAY SYSTEMS	F11-A	5	BTRY	OPT	AGSP / DISPLAY / HYD FPB - BRK SW
F7-F	30	BTRY	OPT	HYD FPB-SOL'D VAL / AUX PWR SOURCE	F11-B	5	IGN	OPT	ENGINE BODY BUILDER
F7-G	10/20	BTRY	OPT	DRIVER SEAT / AND PASSENGER SEAT	F11-C	5	IGN	OPT	LIFT AXLE
F7-H	30	BTRY	OPT	POWER WINDOW/DOOR - RIGHT REAR	F11-D	5	---	OPT	FUEL COOLER COOLANT SOLENOID (VB)
F8-A	10	BTRY	OPT	TRANSMISSION SHIFTER					
F8-B	30/15	BTRY	OPT	BENDIX AIR ABS / WABCO AIR ABS					

- NOTES:
- 20A W/BODY ACCESSORY  
25A W/TRAILER AUXILIARY CENTER PIN - ACC OR BAT  
30A W/TRAILER AUXILIARY FEED
  - 10A ALLISION TRANSMISSION  
30A EATON AUTOSHIFT OR ULTRASHIFT TRANSMISSION
  - AUTO NEUTRAL RELAY  
START ENABLE RELAY  
COLUMN SHIFTER RELAY

- 20A CAT ENGINE  
30A CUMMINS ENGINE  
25A INTERNATIONAL BIG BORE (1BBE)
- PARK BRAKE RELAY  
ECM POWER RELAY (1BBE)  
FAN RELAY (16/VB)
- HYDRAULIC BRAKE WARN RELAY  
TRIP HEADLIGHT INPUT RELAY  
LIFT AXLE REVERSE RELAY

# Roadside Emergencies

## Tilt Hood

### Raising the Hood

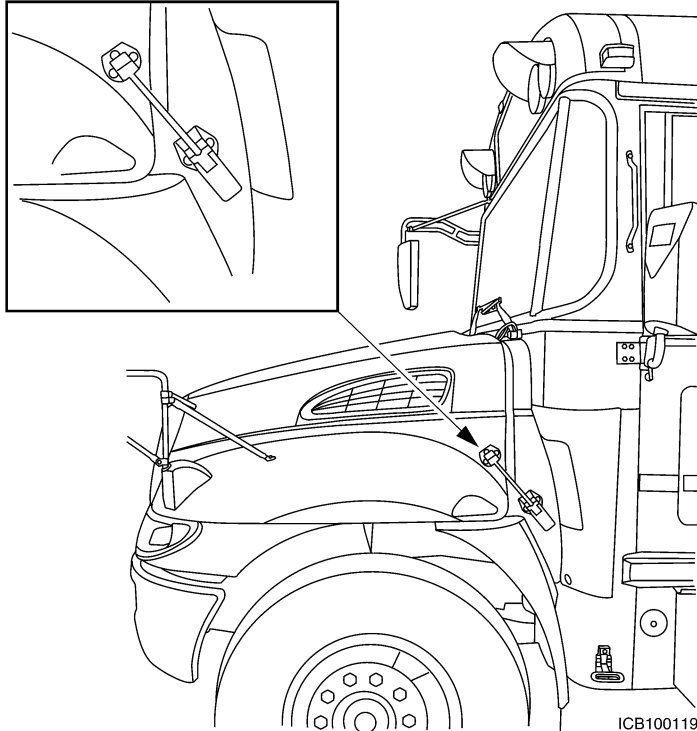

Release the latches on both sides of the cowl.

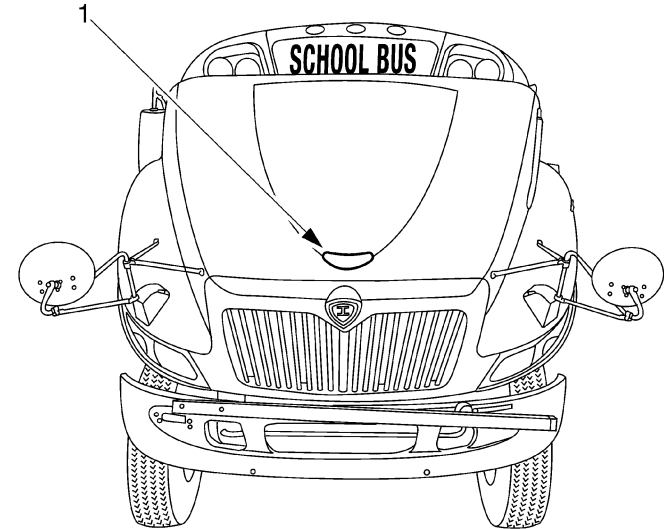

1. Grab Handle

**NOTE: Never use the crossview mirrors as a grab handle. Mirror damage and misadjustment can occur.**

Grab the hood handle and pull the hood forward over center and allow it to settle into the raised position.

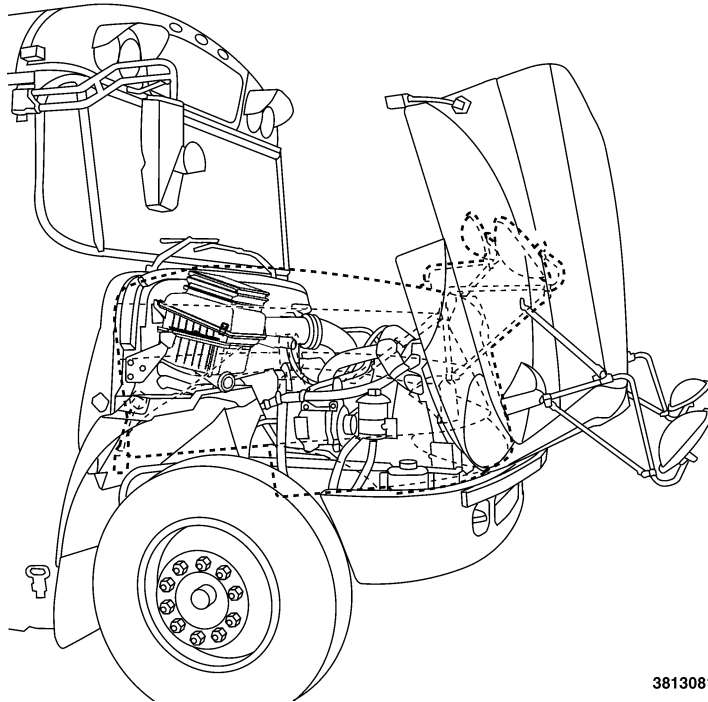

### *Lowering the Hood*

**NOTE: Make sure that the hood has no tools / parts / people in its path of motion.**

Grab the hood handle and push the hood backward over center and allow it to settle into lowered position.

Engage the latches at both sides of cowl.

### Emergency Starting Using Jumper Cables



To prevent property damage, personal injury, and / or death, the following procedures must be performed exactly as outlined; otherwise, a fire or a battery explosion could occur.

### CAUTION

To prevent electronic component damage, never exceed 16.0 volts to vehicle's electrical system. When it is necessary to jump-start a vehicle, the most reliable means is to connect charged 12-volt batteries.

1. Remove metal rings or watches and do not allow metal tools to contact positive terminal of battery to prevent shorting of the electrical system.
2. Place transmission in Neutral and set parking brake in both vehicles.
3. Shut off lights, heater, air conditioner and any other electrical loads in both vehicles.
4. Eye protection should be worn if available. If not available, shield eyes when near either vehicle's batteries.
5. Make sure the vehicle bodies or bumpers are not touching.

## Roadside Emergencies

---

6. Connect one end of the first jumper cable to positive (+) terminal of the dead battery or (+) terminal of jump start stud and then the other end to the positive (+) terminal of the booster battery.
7. Connect one end of the second jumper cable to negative (-) terminal of the booster battery and the other end to chassis frame of the vehicle with the discharged battery. Do not attach the other end to the negative (-) battery terminal of the discharged battery, because a spark could occur and cause explosion of gases normally present around the battery.
8. Reverse above procedure when removing the jumper cables.

## Towing Instructions



To prevent property damage, personal injury, and / or death, always install wheel chocks when manually releasing the spring brakes. For towing make sure the vehicle is securely connected to the tow vehicle and the tow vehicle parking brakes are applied before releasing the disabled vehicles parking brakes.



To prevent property damage, personal injury, and / or death, always use both tow hooks to prevent possible overloading and breaking of individual hooks. This vehicle may be equipped with (optional) dual tow hooks for recovery purposes only.



To prevent property damage, observe the following: Due to many variables that exist in towing, positioning and lifting, towing is the sole responsibility of the towing operator.

Refer to the differential and transmission equipment manufacturer for specific instructions on towing your vehicle. Further information can be located in the component owner manual that came with this truck on delivery for original sale.

Damage caused by improper towing procedures is not a warrantable failure.

Remove tow hooks from their installed position in the front of the vehicle before operating the vehicle. Failure to do so could result in the tow hooks becoming unintentionally detached from the vehicle.



### CAUTION

To prevent transmission damage, vehicles should not be towed even short distances without suspending rear wheels or removing the axle shafts or propeller shaft.

In the event the chassis is equipped with tandem axles and the vehicle is to be towed from the front, the forward rear axle may be raised to clear the road surface and secured to the frame by chains or U-bolts, allowing only rear axle to contact road surface. Axle shafts must be removed from rear axle assembly. The wheel hub ends must be covered to prevent loss of axle lubricant and entrance of contaminants. Use extreme care in securing the chains or U-bolts to prevent possible damage of brake lines, hoses, or other components.

### CAUTION

To prevent vehicle or engine component damage, do not use the front or rear bumper as a lift point when lifting or jacking the vehicle.

**NOTE:** Important factors to keep in mind when using tow hooks:

- Use both tow hooks when retrieving vehicle.
- Use a slow steady pull, do not jerk on hooks.
- Tow hooks are not designed for towing, retrieval only.

Before moving the towed vehicle, check for adequate road clearance of vehicle components. IC Bus, LLC recommends unloading the towed vehicle prior to towing to reduce any abnormal loads to the vehicle components resulting from the towing procedures. Before towing, be sure to fully release the parking brake; either Air or Hydraulic brake system.

### Towing Preparation: Air Parking Brakes

The spring actuated type parking brake can be released by recharging the air system with at least 441 kPa (64 psi) of air. If brake system does not retain air pressure, then manually cage the spring brakes.

### Towing Preparation: Hydraulic-Powered Parking Brakes

If battery power is available:

1. Place the transmission in "N" (Neutral) and turn the ignition switch to the ON position.
2. While depressing the brake pedal, push and hold the Parking Brake knob to release the parking brake.

If battery power has been lost, the Parking Brake cable will have to be disconnected by following the steps below (see illustration):

### CAUTION

To prevent vehicle and / or component damage, while removing the parking brake cable, only the threaded rod should rotate. If the cable is to be reused, do not allow the cable to twist during removal.

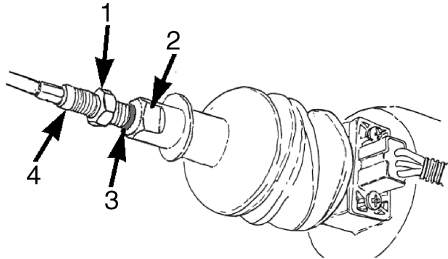

3813013

### Parking Brake Cable Assembly

1. 16mm Jam Nut
  2. SAHR Canister Shaft 15mm
  3. Adjustment Indicator, 'HASH' Mark
  4. Threaded Rod 8mm
1. Install wheel chocks, place the transmission in "N" (Neutral), and turn the ignition switch to the OFF position.
  2. While using a 15 mm wrench to hold the SAHR canister shaft, loosen the jam nut on the threaded rod with a 16 mm wrench.

3. While using the 15 mm wrench to hold the canister shaft, unscrew the threaded rod using an 8 mm wrench. The rod must be unscrewed approximately 6 cm (2.5 in) before the cable disconnects. The cable will exhibit some resistance while being unscrewed because it is under tension.

### Towing Vehicle With Front Wheels Suspended

When it is necessary to tow a vehicle with the front wheels suspended, extra precautions must be taken to avoid transmission or differential damage.

Disconnect the axle shafts at the rear axle to prevent the wheels from driving the differential and the transmission. If axle shaft is not disconnected, remove the rear axle shafts from the axle assembly. Cover the wheel hub ends to prevent loss of axle lubricant and entrance of contaminants.

### Towing Vehicles With Rear Wheels Suspended

Whenever possible, it is preferable to tow a disabled vehicle from the rear by raising the rear of the chassis. When towing a vehicle with the rear of the chassis suspended, the front wheels must be locked in the straight ahead position.

---

## SECTION 11 — CLEANING



To prevent property damage, personal injury and / or death, shift transmission to park or neutral, set parking brake, and install wheel chocks before performing diagnostic or service procedures.



To prevent property damage, personal injury and / or death, read and adhere to all safety instructions on the labels of all cleaners. Many cleaners contain solvents that may become concentrated in the vehicle interior breathing space. While cleaning the interior area, maintain adequate ventilation by opening windows and doors.



To prevent property damage, personal injury and / or death, read and adhere to all safety instructions on the labels of all cleaners. While most cleaning products are safe when used individually, certain cleaners can form hazardous gases if mixed with other cleaning products.

**NOTE:** Chemicals used to clean or disinfect your IC Bus can adversely affect materials used to build the vehicle. Many common cleaning chemicals can damage or ruin the appearance of materials like ABS plastic, vinyl, rubber, aluminum, glass and painted surfaces. As with the cleaning chemicals used, the cleaning process (or the lack of a cleaning process), can also affect the life and appearance of the vehicle.

Chemicals used in premixed or aerosol disinfectant solutions can damage or affect the appearance of many interior surfaces.

The following information should be used to determine an acceptable method to clean your vehicle while maintaining the appearance and integrity of the components to be cleaned.

### Surface Cleaning

#### General Cleaning, All Surface Types

Use a soft dry cloth on hard surfaces and a whisk broom or vacuum cleaner on flooring and upholstery to remove loose dirt and debris. Surfaces can then be washed with a damp cloth and a warm water and mild soap solution. Use a clear water damp cloth rinse to remove soap residue, then wipe dry.

## Cleaning

---

**NOTE:** When using isopropyl alcohol as a disinfectant, the following precautions must be followed.

- Do not use a 70% isopropyl solution as a wash solution.
- Do not use a 70% isopropyl solution wipe on seats that are hot from daytime heat.
- Vapors can accumulate quickly when using a 70% isopropyl solution wipe. Maintain adequate ventilation by opening windows and doors.
- The effectiveness of the 70% isopropyl solution can be diminished when used in high heat conditions due to evaporation.

A 70% solution of isopropyl alcohol can be used as a disinfectant wipe. A 70% isopropyl solution is readily available from local sources.

### ABS / Plastic

Plastic (ABS, Thermal Plastic, Plastic) material should only be cleaned with a warm water and mild soap solution.

### Glass

**NOTE:** Use of abrasive cleaners can scratch or damage glass.

Use a soft cloth and glass cleaner only.

## Interior

The best method to preserve the appearance and extend the life of the interior components of your IC Bus is frequent and thorough cleaning of the components. A cleaning schedule and the cleaning requirements should be determined based on the type of service conditions in which the unit is operated.

### Interior Light Bar Cleaning

All Interior Light Bars are only to be cleaned with a mild detergent and warm water. No other cleaners are to be used, as they may damage the surface.

### Upholstery Care



**To prevent property damage, personal injury, and / or death, observe the following. Disinfectant products can contain solvent based chemicals that can adversely affect seat belt components.**

Use a whiskbroom and vacuum cleaner to remove loose dust and dirt from upholstery and floor. Wash vinyl and woven plastic upholstery with warm water and mild soap. Wipe dry. If commercial cleaners are used, follow instructions supplied with cleaner.

### Flooring

**NOTE: Some buses are built with an insulating wooden sub-floor under the floor covering. Do not use a hose to clean the interior floor of the bus. Standing water may damage the wood sub-floor.**

Use a damp mop with warm water and mild soap solution. Use a clear water damp mop rinse to remove soap residue. Remove any excess water remaining on the flooring after the rinse process.

Floor mounted wheelchair track should be clean of dirt, debris and cleaning solution residue when completed. Many chemicals used to maintain roads and walkways are tracked into the bus and may react with the cleaning solution. Failure to properly clean the floor track can result in track deterioration.

### Exterior

**NOTE: Certain cleaners contain chemicals that can damage emblems and decals. If the cleaning product label states that it should not be used on plastic parts, do not use the product to clean the unit or damage may occur that would not be covered by warranty.**

The best way to preserve painted surface finish is to keep it clean by washing it often. Frequent and regular washing will lengthen the life of the vehicle's painted finish.

Wash the vehicle often with warm or cold water to remove dirt and preserve the original luster of the paint.

- Never wash the vehicle in the direct rays of the sun or when the sheet metal is hot to the touch as this may cause streaks in the finish.
- Do not use hot water, strong soaps or detergents.
- Never wipe dirt off a dry surface as the dirt will scratch the paint.

Always make certain that steps, and grab handles, or any external accessories or components attached to the body exterior, are clean and free of road grime, salt, grease, ice and other debris.

To maintain optimum vehicle preservation, wash the vehicle thoroughly immediately after operating it in the presence of road salts. Many municipalities are now using magnesium chloride and calcium chloride salts in the winter time. These salts are much more corrosive than typical sodium chloride salt and must be brushed-off in addition to spraying with high-pressure water. Merely rinsing surfaces exposed to these chemicals will not remove them fully.

In addition to the body, it is highly recommended, because of the various road chemicals used in harsh winter weather, that the under chassis and wheel ends be pressure washed during the winter and spring breaks. Adverse weather and road conditions may require more frequent washing. When exposed to heavier amounts of road chemicals, clean the vehicle as soon as possible.

## **Cleaning**

---

### **Waxing or Polishing Vehicles**

Thoroughly wash the vehicle before using any wax or polish. Use a high quality paste wax and follow the wax manufacturer's instructions to help prevent bus paint from fading.

### **Crossing Arm Cleaning**

The Crossing Arm is only to be cleaned with a mild detergent and warm water. No other cleaners are to be used, as they may damage the surface.

---

## SECTION 12 — MAINTENANCE

### Preface



To prevent property damage, personal injury, and / or death, if the owner / operator of the vehicle is a skilled technician and intends to perform the vehicle maintenance and servicing, they are strongly urged to purchase and follow the appropriate IC Bus, LLC Bus, MaxxForce® Engine or Allison Transmission service manuals or OnCommand™ Service Information DVD. Ordering information is included at the back of this manual.



To prevent property damage, personal injury, and / or death, observe the following. This vehicle has many parts dimensioned in the metric system as well as the English system. Some fasteners are metric and are very close in dimension to English fasteners in the inch system. Mismatched or incorrect fasteners can loosen and reduce clamping load, which could result in vehicle damage, personal injury or death.

**NOTE:** For vehicles equipped with Cummins ISB® engines, refer to Cummins QuickServe® Online, your Cummins Engine Operation Manual, or contact a certified Cummins repair location for specific engine maintenance intervals, capacities, and instructions.

Your bus has been engineered and manufactured to provide economical and trouble free service. However, it is the owner's responsibility to make sure the vehicle receives proper care and maintenance.

IC Bus, LLC service parts and MaxxForce® engine service parts are available through your IC Bus, LLC dealer. If IC Bus, LLC and MaxxForce® engine service parts are not used, the owner must make sure the parts used are an equivalent.

As with any machine, take care to avoid being injured when performing maintenance, repairs or inspections. Improper or incomplete service could result in the vehicle not working properly which, in turn, may result in personal injury, damage to the vehicle or its equipment, or death. If you have any questions about performing some service, contact your nearest IC Bus, LLC bus or MaxxForce® engine dealer or have the service done by a skilled professional technician.

### Maintenance Guidelines

When servicing your bus, always:

- Turn off the engine unless the procedure calls for a running engine.
- Set the parking brake and install wheel chocks.

## Maintenance

---

- Use support stands, not a jack, whenever you must be under a raised vehicle.
- Do not smoke.
- Wear safety glasses for eye protection.
- Operate the engine only in a well ventilated area.
- Do not work on brakes unless the proper precautions have been taken to avoid inhaling friction material dust.
- Do not wear loose clothing, hanging jewelry, watches or rings. Tie up hair when around rotating machinery.
- Avoid contact with hot metal parts; allow hot components to cool before working on them.
- Repair or replace any defects that were revealed during inspection, prior to operating the vehicle.



**To prevent property damage, personal injury, and / or death, do not make modifications to any part, component, or system of the vehicle, as that can adversely affect the quality and reliability of your vehicle.**



**To prevent property damage, personal injury, and / or death, observe the following. Use only genuine IC Bus™ or MaxxForce® engine service parts. The use of inferior parts can adversely affect the quality and reliability of your vehicle.**



**To prevent property damage, personal injury, and / or death, take care when performing any maintenance or making any checks or repairs. Some of the materials in this vehicle may also be hazardous if used, serviced, or handled improperly. If you have any questions pertaining to the service, have the work done by a trained technician.**



**To prevent property damage, personal injury, and / or death, park vehicle on hard flat surface, turn the engine off, set the parking brake, and install wheel chocks to prevent the vehicle from moving in either direction.**



**To prevent property damage, personal injury, and / or death, whenever disconnecting battery terminals, always disconnect ground terminal first. When reconnecting, always connect ground terminal last. Failure to follow this procedure could also result in a short to ground.**



## Supporting Your Vehicle for Service



**To prevent property damage, personal injury, and / or death, always use floor stands to support the vehicle before working under it. Using only a jack could allow the vehicle to fall.**

When performing service repairs on a vehicle, first:

1. Park vehicle on level concrete floor.
2. Set parking brake and / or block wheels to prevent vehicle from moving.
3. Select jack with a rated capacity sufficient to lift and hold up the vehicle.
4. Raise vehicle with jack applied to axle(s). (DO NOT use bumper as a lifting point.)
5. Support vehicle with floor stands under axle(s).

If axle or suspension components are to be serviced, support vehicle with floor stands under frame side members.

## Pre-Trip and Post-Trip Inspections

Pre-Trip inspections should be performed each day by the operator before operating this vehicle. In many circumstances, a Post-Trip inspection can be even more valuable since it may reveal problems in time for service work to be performed prior to the next trip. This can help to minimize unwelcome surprises and unscheduled downtime. A convenient checklist of items to

include in a Pre / Post Trip Inspection are identified in Section 2 – Vehicle Inspection Guide as well as Commercial Driver's License (CDL) Manuals.

## Chassis Lubrication

New vehicles are lubricated at the factory. After the vehicle is placed in operation, regular lubrication and maintenance intervals, based on the type of service and road conditions, should be established. The loads carried, speed, road and weather conditions all contribute to the frequency of lubrication intervals. Thorough lubrication and maintenance at the specified intervals will insure Outstanding Life Cycle Value and will reduce overall operating expense.

In some types of operation, and where operating conditions are extremely severe (such as in deep water, mud or unusually dusty conditions), the vehicle may require re-lubrication after every twenty-four (24) hours of operation.

Only lubricants of superior quality, such as Fleetrite® lubricants, should be used. The use of inferior products will reduce the service life of the vehicle or result in failure of its components. IC Bus, LLC recommends the use of Fleetrite® lubricants and IC Bus, LLC and MaxxForce® Engine original equipment parts.

The lubrication intervals specified should be performed at whatever interval occurs first, whether it is kilometers (miles), hours, or months.

Refer to the Lubrication and Maintenance Intervals Chart at the end of this section for further details.

### Engine Compartment Fluid Check Points

**NOTE:** Location of surge tank, power steering reservoir, washer bottle, transmission dipstick, air cleaner, oil fill tube, and oil dipstick may vary depending on model year and engine type.

**NOTE:** The following illustrations are for reference only and may slightly differ from the actual vehicle.

**NOTE:** For vehicles equipped with Cummins ISB® engines, refer to Cummins QuickServe® Online, your Cummins Engine Operation Manual, or contact a certified Cummins repair location for specific engine maintenance intervals, capacities, and instructions.

### MaxxForce® 7 Engine (Left Side View)

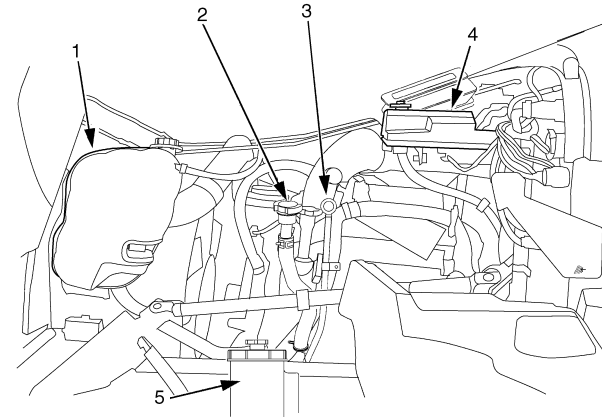

3813014

1. Engine Coolant Level
2. Engine Oil Level
3. Transmission Fluid Level
4. Brake Fluid Level
5. Power Steering Fluid Level

MaxxForce® 7 Engine (Right Side View)

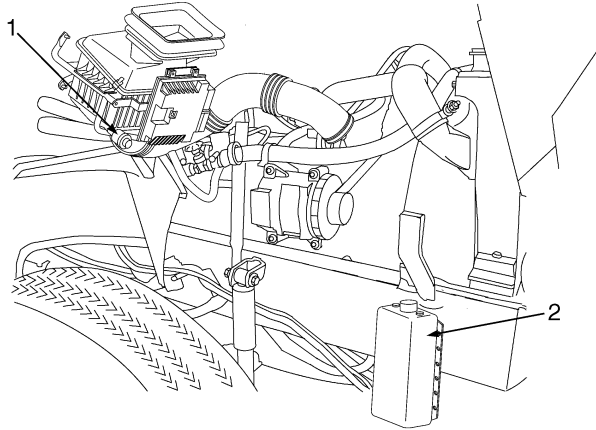

3813015

1. Air Filter Restriction Gauge
2. Windshield Washer Fluid Level

MaxxForce® DT Engine (Left Side View)

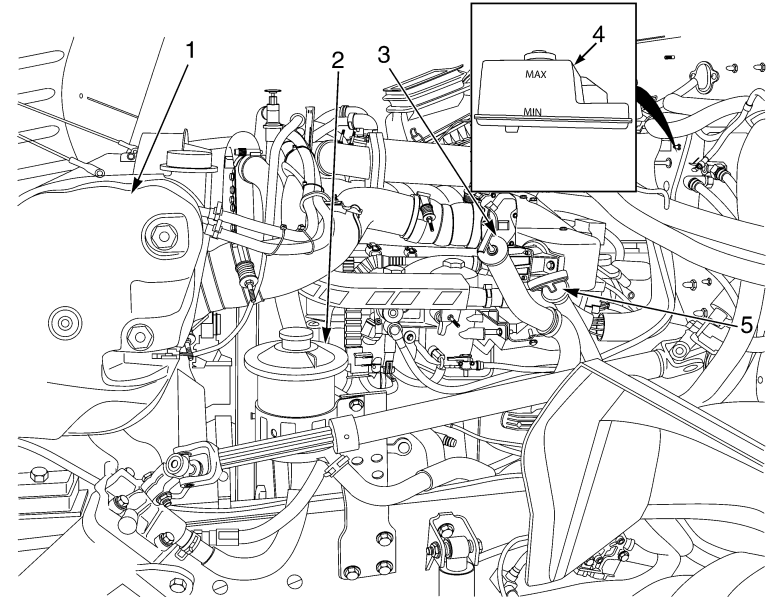

3813079

1. Engine Coolant Level
2. Power Steering Fluid Level
3. Engine Oil Level
4. Brake Fluid Level (if equipped)
5. Transmission Fluid Level

## Maintenance

---

### MaxxForce® DT Engine (Right Side View)

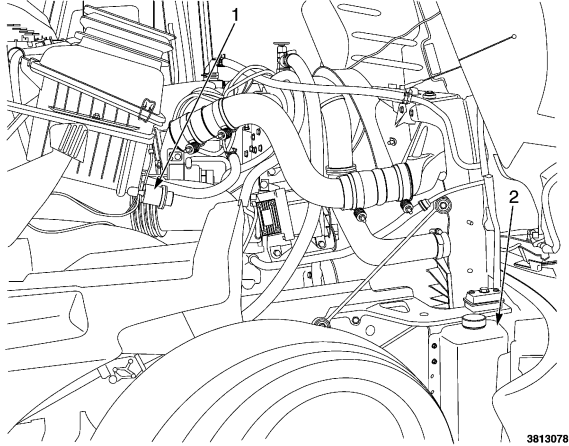

3813078

1. Air Filter Restriction Gauge
2. Windshield Washer Fluid Reservoir

## Air-Operated Passenger Door Adjustments

The air operated door opening and closing speeds can be adjusted by the air control valve. The air valve is located behind the access panel above the entrance door. The closing force of the entrance door is determined by the adjustment of the pressure regulator. To perform these adjustments, open access panel door and use the procedures below.

### Door Opening and Closing Speed Adjustment Points

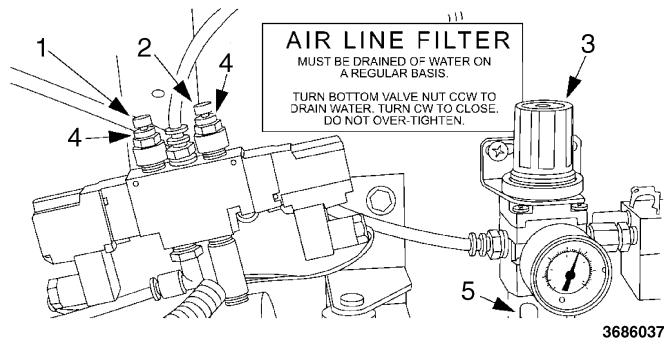

1. Opening Speed Screw
2. Closing Speed Screw
3. Pressure Regulator Adjustment Knob
4. Locknuts
5. Air Filter

### Pressure Regulator Adjustment



**To prevent property damage, personal injury, and / or death, do not replace the air door regulator with one that allows pressure settings above 60 psi (414 kPa).**

A properly adjusted entrance door should take approximately 4 - 5 seconds to open or close depending on the pressure and speed settings.

The pressure regulator should be set at approximately 40 - 50 psi (276 - 345 kPa). The regulator can only be set to a maximum of 60 psi (414 kPa). The door operates best at 40 psi (276 kPa). In cold weather, seals may stiffen and require more air pressure for proper operation. The pressure can be increased by lifting and turning the adjustment knob (3) clockwise. Then press the cap back down.

### Opening Speed Adjustment

Loosen the locknut (4) and turn the opening speed screw (1) clockwise to slow the door opening speed, or counterclockwise, to increase the door opening speed. Tighten the locknut (4).

### Closing Speed Adjustment

Loosen the locknut (4) and turn the closing speed screw (2) clockwise to slow the door closing speed, or counterclockwise, to increase the door closing speed. Tighten the locknut (4).

## Maintenance

### Electrically Actuated Entrance Door Adjustment

Electrically actuated doors are set to operate in 2 to 2 ½ seconds. There is no adjustment for electrically actuated door opening and closing speed.

### Axles

821280

MANUFACTURED BY IC CORPORATION				
DATE OF MANUFACTURE				
5		MO. 03 YR.		
GVWR	12474	KGS(	27500 LBS)	
GAWR FRONT	4536	KGS(	10000 LBS)	
GAWR REAR	7938	KGS(	17500 LBS)	
WITH	265/75R22.5G	TIRES	1.4 PLY	
WITH	245/75R22.5G	TIRES	1.4 PLY	
AT	759	KPa(	110 PSI) COLD	
AT	759	KPa(	110 PSI) COLD	
RIMS	.22.5X7.50		RIMS	22.5X7.50
THIS VEHICLE CONFORMS TO ALL APPLICABLE FEDERAL MOTOR VEHICLE SAFETY STANDARDS IN EFFECT ON THE DATE OF MANUFACTURE SHOWN ABOVE.				
VEHICLE IDENTIFICATION NO. 4DRBRAAPX3A953275				
VEHICLE TYPE SCHOOL BUS BODY# 953275MD				
452308001				

ICB100112

### Typical Axle, Tire, and Rim Specifications-Vehicle Identification Label

#### Front Axle – Inspection and Lubrication

Check to make sure that the front axle mounting U-bolts and nuts are securely tightened.

Check front axle for damaged, binding, or worn parts, and adequate lubrication.

- Kingpin wear inspection requires that no weight is on the tires.
- Kingpin and Kingpin Bushing lubrication requires that the vehicle weight is off tires prior to installing grease to maximize grease distribution.
- Kingpin Thrust Bushing lubrication requires that the vehicle weight is resting on the tires.
- Power grease guns may be used. However, a hand-pumped grease gun should be used for optimal grease distribution within each component joint.

Refer to the LUBRICATION AND MAINTENANCE INTERVAL CHART and the LUBRICANT AND SEALER SPECIFICATIONS CHART at the end of this section for additional information.

- Inspect, lubricate, and adjust the wheel bearings at regular intervals. Refer to LUBRICATION AND MAINTENANCE INTERVAL CHART at the end of this section for recommended service intervals. Also refer to LUBRICANT AND SEALER SPECIFICATIONS and TORQUE SPECIFICATIONS at the end of this section.

#### Front Axle – Normal Maintenance

During operation the air and oil inside the hub / wheel cavity expands. It is normal for a mist of oil to be present on the outside of the hubcap around the vent slit or hole. Over time, if not wiped off, this film may collect dust and appear unsightly. If the entire

face and end of the hubcap become wet with oil, investigate the cause. Refer to the Service Manual for repair procedure.

Routinely clean the hubcap to ensure that the lube level can be easily observed through the clear window as intended. In situations where the window is clean on the outside but discolored on the inside, check the lube level by removing the rubber fill / vent plug and insert a finger into the hole.

The specified lube level for clear window type hubcaps is from the minimum line to 8 mm (5/16 in) above the minimum line.

If the lube level suddenly drops dramatically below the minimum level, see the Service Manual for diagnostic procedure.

### Front Axle – Alignment

Maintaining front axle alignment is very important to achieve maximum tire life and vehicle control. Inspecting steer axle tires in the first 3,000 to 10,000 service miles will generally show if tires are wearing normally.

- Rapid outside shoulder wear on both tires indicates too much toe-in.
- Rapid inside shoulder wear on both tires indicates too much toe-out.
- Excessive wear on the inside or outside of one steer tire but not the other can indicate a toe-in or toe-out condition coupled with a misaligned front or rear axle.

- Pulling to the right or left can indicate misalignment of the front or rear axle, unequal tire pressures, or a defective / mismatched tire.

Refer to the TIRES subsection for additional related information.

### Rear Axle – Inspection and Lubrication

Make sure the axle mounting U-bolt nuts, and attaching or mounting bolts and nuts are securely tightened. Loose or misaligned rear axles will affect vehicle alignment, front tire wear, and handling. Refer to AXLE U-BOLT NUT TORQUE CHART at the end of this section for torque specifications.

Check the rear axle oil level. Proper oil level minimizes gear wear, heat and damage to the wheel bearings and seals. The oil level should be at the lower edge of the level inspection hole when the vehicle is on level ground. Add oil as necessary.

Refer to the LUBRICATION AND MAINTENANCE INTERVAL CHART and The LUBRICANT AND SEALER SPECIFICATIONS CHART at the end of this section for additional information.

### Body

Inspect the undercoating of school buses annually and recoat as required.

Refer to Section 2 – Vehicle Inspection Guide and the LUBRICATION AND MAINTENANCE INTERVAL CHART at the end of this section for items to be inspected / serviced and recommended service intervals.

### Brakes

#### General Information

All new IC Buses are manufactured with non-asbestos brake linings. However, exposure to excessive amounts of brake material dust may be a health hazard.



**To prevent vehicle damage, personal injury and / or death, pay strict attention to the following: if your vehicle is equipped with Automatic Traction Control or any type of locking or limited slip differential, power will be transmitted to the opposite wheel should one of the wheels slip. Both wheels must be raised free of the ground should it be necessary to operate one wheel with the vehicle stationary; otherwise, the wheel that is not raised will pull the vehicle off its support.**



**To prevent personal injury and / or death, avoid breathing brake lining fiber dust. Always use a respirator while performing brake maintenance. Follow precautions listed below.**



**To prevent property damage, personal injury, and / or death, always check and maintain brakes in proper condition and adjustment. Out-of-adjustment brakes could cause reduced braking ability.**

Follow the these precautions:

- Always wear a respirator approved by the National Institute of Occupational Safety and Health (NIOSH) or the Occupational Safety and Health Administration (OSHA) during all brake service procedures. Wear the respirator during removal of the wheels until assembly is complete.
- Never use compressed air or dry brushing to clean brake parts or assemblies.
- Clean brake parts and assemblies in the open air. During disassembly, carefully place all the parts on the floor to avoid getting dust in the air. Use an industrial vacuum cleaner with a HEPA filter system to clean dust from the brake rotors / drums, backing plates, and other brake parts. After using the vacuum, remove any remaining dust with a rag soaked with water and wrung until nearly dry.
- NEVER use compressed air or dry sweeping to clean the work area. Use an industrial vacuum cleaner with a HEPA filter system and rags soaked in water and wrung until nearly dry. Carefully dispose of used rags to avoid getting dust into the air. Use an approved respirator when emptying vacuum cleaners and handling used rags.



- Wash your hands before eating, drinking or smoking. Vacuum work clothes exposed to brake dust after every use and launder them separately, without shaking them, to prevent dust from getting in the air.

## Air Brakes

### *Brake Inspection and Adjustment*



To prevent property damage, personal injury, and / or death, always install wheel chocks when manually releasing the spring brakes, or the vehicle could roll.



To prevent property damage, personal injury, and / or death, under no circumstances should a spring brake chamber be disassembled. Disassembly will release a powerful spring.



To prevent property damage, personal injury, and / or death, pay strict attention to the following. Brake Automatic Slack Adjusters (ASA) should not need to be manually adjusted in service. ASAs should not routinely have to be adjusted to correct excessive pushrod stroke. Excessive stroke indicates that a problem exists with the foundation brake, ASA, brake actuator, other brake system components or their installation or adjustment.

In the event that a manual adjustment must be made (although this should not be a common practice), a service appointment and full foundation brake, ASA, and other brake system component inspection must be conducted as soon as possible to ensure the integrity of the overall brake system prior to returning the vehicle to service.

IC Bus, LLC recommends that you establish a regular schedule for periodic cleaning, lubrication, adjustment and inspection of brakes, based on the type of vehicle operation. It is difficult to predetermine an exact maintenance interval (time or mileage), since vehicles are used in a variety of applications and conditions. If you are uncertain of the proper schedule and procedures for your vehicle, contact your IC Bus, LLC dealer.

Periodically, check the push rod travel or brake adjustment. Check the push rod travel every service interval to determine if adjustment is necessary. Brake chamber push rods on original equipment chambers have a stroke indicator (an orange /

red paint marker / rib near the base of the push rod) to aid adjustment checks. If the push rod is clean and the brakes require adjustment, the orange / red marker can be seen protruding from the chamber when the brakes are applied.

Check the slack adjusters to ensure proper operation of the adjuster mechanism. Push rod travel should be at a minimum without brakes dragging.

This inspection or adjustment should only be performed by qualified service personnel and must be in accordance with instructions provided by the IC CE Service Manual.

At regular intervals, inspect the entire brake system. Check:

- Rubber components for deterioration. Replacement intervals vary according to environmental severity and time in service.
- Condition of rotors / drums, brake chambers, and slack adjusters.
- System for air leaks.
- Hose or pipes for corrosion, damage, deterioration.
- Operation of service and parking brakes.

Periodically, inspect the air brake chamber diaphragm, air compressor and air cleaner, and replace if unserviceable. Refer to Section 2 - Vehicle Inspection Guide as well as the LUBRICATION & MAINTENANCE INTERVALS CHART later in this section.

Inspect brake lining at every maintenance interval. When brake lining or blocks are worn to within 1.6 mm (1/16 in) of the rivets, replace the brake lining.

### *Air Dryer*

The function of the air dryer is to collect and remove moisture and contaminants before the compressed air reaches the air reservoirs. This protects the air system components from malfunctioning including blockage, corrosion, and freezing. For air tank draining requirements, refer to the Maintenance Instructions section as well as local regulations.

The air dryer is installed in the discharge line between the air compressor and the air system reservoirs. The air dryer includes a replaceable desiccant cartridge and oil blocking filter that is periodically serviced. It also may include a heater to prevent the discharge valve from freezing in cold weather.

### *Air Dryer Desiccant Replacement*

Open reservoir drain valves and check for presence of water. Small amounts of water due to condensation is normal. If the wet (air) tank and primary or secondary tanks are collecting an abnormally high amount of water between regular air tank drain intervals, replace the air dryer desiccant.

The air dryer desiccant replacement interval may vary; it is generally recommended that the desiccant be replaced every 12 months for small air dryers like the Bendix AD-IP<sup>®</sup>, or every 24 months for large air dryers like the Bendix AD-9<sup>®</sup>. If experience has shown that extended or shortened life has resulted for a particular installation, then the interval should be increased or reduced accordingly.

### *Air Dryer Purge Valve*

Check that the purge valve opens and expels moisture when the air governor shuts off the air compressor. Air should escape rapidly and then quickly stop. If the purge valve does not open, or you can hear a slight audible air leakage past the valve for longer than 30 seconds, the valve may be sticking and should be rebuilt. Purge valves may also stick if the air dryer heater has failed and ice is clogging the valve.

### *Air Dryer Heater*

Check that the air dryer heater activates at temperatures below freezing. With the vehicle in a cold environment and before the engine is started, turn on the ignition and touch the air dryer housing. It should be warmer than other metallic items on the vehicle. If some warmth cannot be felt it, may indicate that the heater element or the wiring powering it should be serviced.

### *Air Reservoir / Tanks Moisture Draining*

Moisture taken in with the air through the compressor inlet valves collects in the reservoirs. Drain the wet tank reservoir every day at the end of the trip. Drain the primary and secondary tanks periodically. Open the drain cock located either on the bottom of the tank or in the end of the tank. For ease of draining, some or all tanks may be equipped with optional pull cords. There must be some air pressure in the system to ensure proper drainage. Close the drain cocks after all moisture has been expelled. If you are unsure which tank is the wet tank, drain all tanks daily.

On vehicles equipped with automatic drain valve(s), moisture and contaminants are automatically removed from the reservoir

to which it is connected. It operates automatically and requires no manual assistance or control lines from other sources. Periodically, manually drain the reservoir and make sure the drain passage is not plugged.

Some vehicles are equipped with remote air piloted drain valves. These are actuated (drained) using dedicated individual controls from the driver's control panel.

### *ABS Connections and Sensors*

Periodically, push together the ABS wiring connections to ensure they are fully seated. Press the wheel speed sensors into their mounting collars to ensure they are fully seated.

### **Hydraulic Full Power Brakes**

#### *Brake Inspection and Adjustment*

This inspection or adjustment should only be performed by qualified service personnel and must be in accordance with instructions provided by the BE Bus Service Manual.

Establish a regular schedule for periodic cleaning, lubrication, and inspection, based on the type of vehicle operation. It is difficult to predetermine an exact maintenance interval (time or mileage) since vehicles are used in a variety of applications and conditions. Refer to the LUBRICATION AND MAINTENANCE INTERVAL CHART later in this section for recommendations.

On a periodic basis of at least once per year inspect the entire brake system for:

- The proper operation of the service and parking brakes.

## Maintenance

---

- The condition of the discs, calipers, and ABS exciter teeth.
- Hydraulic fluid leaks.
- Hose or pipe damage.
- The condition of the ABS wheel speed sensors and wiring.
- Proper ABS wheel speed sensor-to-exciter teeth gap.

Inspect brake lining at every maintenance interval. During severe service operations or prolonged periods of stop-and-go operation, the brakes may require more frequent inspection. Establish inspection intervals that provide for lining replacement before damage to the disc occurs. Excessive lining wear may allow the metal brake shoe to damage the brake disc.

### *Brake Fluid Level*

**NOTE: If brake fluid is added frequently to maintain the proper level in the master cylinder, it means that there is either rapid pad wear or a fluid system leak. A more frequent and thorough brake inspection is required.**

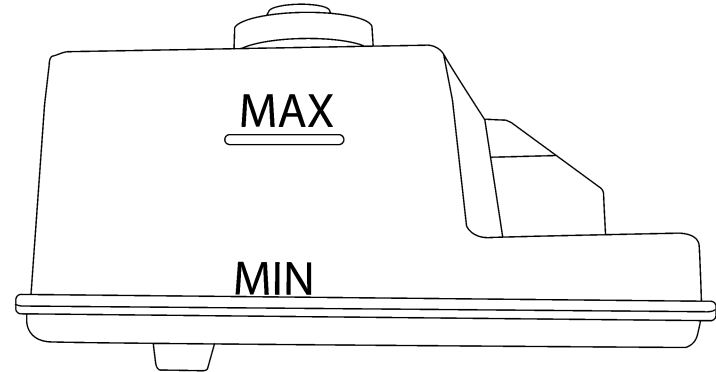

3813018

During normal vehicle operation and servicing, the fluid level will vary between the MIN and MAX lines on the master cylinder mounted front reservoir. Do not fill the master cylinder to the top of the reservoir. Over filling may lead to overflow. **DO NOT add fluid above MAX line.**

### *Fluid Precautions*

Use only DOT 3 Brake Fluid which is properly identified in a sealed container. Avoid brake fluid contact with painted surfaces. It will damage the paint.

### *Brake Lines, Hoses, and Fittings*

- Check lines for kinks, dents, corrosion, or ruptures.

- Check hoses for abrasion, kinks, soft spots, ruptures, collapse, cracks, twists or loose frame supports. When replacing a hose, be sure there is enough clearance to prevent the new hose from rubbing against other components.
- Examine all connections for leaks.
- Repair or replace brake line tubes, hoses or fittings as required.

### *Hydraulic Brake Fluid Accumulators*



**To prevent property damage, personal injury, and / or death, the brake system should only be serviced by qualified personnel in accordance to the instructions in the service manual since it is under high pressure.**

The hydraulic brake fluid accumulators store fluid under pressure. The pressure of the gas in the accumulator may gradually diminish over time. The brake system contains self diagnostics that sense when the accumulators should be replaced. The BRAKE PRESSURE indicator on the Instrument Panel Gauge Cluster will illuminate for multiple reasons including when the accumulators need to be replaced. Accumulator replacement should only be performed by a trained professional.

### *ABS Connections and Sensors*

Periodically, push together ABS wiring connections to ensure they are fully seated. Press the wheel speed sensors into their mounting collars to ensure they are fully seated.

### **Chassis Inspection**

Regular maintenance and replacement of worn, loose, or damaged parts will usually prevent more serious problems from developing later.

The lubrication and maintenance intervals present a good opportunity to inspect the vehicle. Refer to the LUBRICATION AND MAINTENANCE INTERVAL CHART at the end of this section for detailed information on specific chassis items to inspect.

### **Electrical**

#### **Alternator–Starter–Battery Test**

An AVR (Amps-Volts-Resistance) test should be performed periodically by a trained professional. The test checks for alternator amperage output, starter current draw, and battery amperage capacity. This type of testing detects weaknesses that may not yet be apparent during normal daily operations.

#### **Terminal Inspection–Cleaning–Corrosion Protection**

Periodically, inspect electrical connectors in the battery box, electrical panel box and engine compartment for corrosion and tightness. Clean all exposed terminals and apply a lubricant

sealing grease such as Fleetrite®472141–C1 or equivalent. The inspection / cleaning / corrosion protection should include feed through connections, power and ground cable connections for batteries, engines and the starter stud.

Inspect exposed cables for fraying or signs of abrasion.

Connectors that are more subject to corrosion may be disassembled and sprayed with a light coating of dielectric grease. Use grease sparingly. Too much grease will not allow air to escape from the connection and this compressed air will push the connection apart.

### Accessory Feed Connections



**To prevent property damage, personal injury, and / or death, do not increase size of fuse or circuit breaker or change type of breaker supplied with your truck, as this could cause wiring to overheat and possibly burn. Electrical circuits are designed with a particular wire gauge to meet the fuse and circuit breaker current rating.**

Vehicle electrical systems are complex and often include electronic components such as engine and transmission controls, instrument panels, antilock brakes, etc. While most systems still operate on battery voltage (12 volts), some systems can be as high as 90 volts or as low as 5 volts. Refer to the Electrical Circuit Diagram Manuals available from IC Bus, LLC to ensure that any additional body lights and accessories

are connected to circuits that are both appropriate and not overloaded. No modification should be made to any vehicle control system without first contacting your IC Bus, LLC dealer.

## Engine

### General

The vehicle (engine) owner is responsible for the performance of all scheduled maintenance. The required maintenance operations may be performed by the owner or at a service establishment of the owners choosing. Any replacement parts used for required maintenance services or repairs should be genuine IC Bus, LLC or MaxxForce® engine service parts. Use of inferior replacement parts may hinder operation of engine and emission controls and can reduce engine life and / or jeopardize the warranty.

Keep the receipts covering the performance of regular maintenance in case questions arise concerning maintenance. The receipts should be transferred to each subsequent owner of the vehicle (engine).

### CAUTION

**To prevent damage to the MaxxForce® Engine Control Module it should never be directly spray-washed. Failure to heed this caution may result in vehicle and / or engine component damage.**

**NOTE:** For complete operation and maintenance information pertaining to your MaxxForce® engine refer to the Engine Operation and Maintenance Manual provided with the vehicle.

**NOTE:** For vehicles equipped with Cummins ISB® engines, refer to Cummins QuickServe® Online, your Cummins Engine Operation Manual, or contact a certified Cummins repair location for specific engine maintenance intervals, capacities, and instructions.

For effective emission control and low operating cost, perform the maintenance operations listed on the following pages, at the specified periods or mileage intervals indicated (kilometers, miles, hours, or months) in the Engine Operation and Maintenance Manual.

Service intervals are based upon average operating conditions. In certain environments and duty cycles, more frequent servicing may be required.

### Engine Fluids and Contaminated Material



**GOVERNMENT REGULATION:** Engine fluids (oil, fuel, and coolant) may be a hazard to human health and the environment. Handle all fluids and other contaminated materials (such as filters, and rags) in accordance with applicable regulations. Recycle or dispose of engine fluids, filters, and other contaminated materials according to applicable regulations.

### Scheduled Maintenance

For information regarding routine scheduled maintenance such as replacement of oil, filters, coolant, belts, belt tensioners, etc, and inspection and adjustment of items such as valve lash, etc. refer to the Engine Operation and Maintenance Manual supplied with the vehicle.

**NOTE:** For vehicles equipped with Cummins ISB® engines, refer to Cummins QuickServe® Online, your Cummins Engine Operation Manual, or contact a certified Cummins repair location for specific engine maintenance intervals, capacities, and instructions.

### Air Induction System



To prevent property damage, personal injury, and / or death, when performing maintenance and repairs to any turbocharged engine with engine air inlet piping disconnected, a turbocharger compressor air inlet protective shield should be installed over the turbocharger air inlet. Order the protective shield for MaxxForce® engines from your local IC Bus, LLC dealer.

Perform a complete inspection of the air induction system. Disassemble the joints of each aluminum component and inspect for salt build up and chlorine that can cause aluminum particles to flake off and enter the engine combustion chambers.

If corrosion is present (usually appears at the pipe connections), use a wire brush to clean the inside of the pipes and inside the rubber hoses. Clean all components thoroughly before reassembly.

If the intake pipes are pitted at the joint ends, silicone RTV may be used to seal the joints. Make sure that no excess sealant is on the inside of the pipe that can be pulled into the engine. If the service condition of the pipes, hoses, or clamps is questionable, replace them.

- Check for loose hoses and clamps.
- Check for ruptured or collapsed hoses.
- Check air cleaner housing for cracks.

### Air Cleaner Element Service

**NOTE:** Do not change the air cleaner element configuration from the factory installed configuration. If equipped with a single element or dual element that configuration must stay with the vehicle. Failure to comply may affect engine performance.

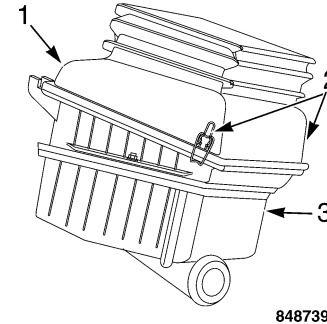

1. Inlet Lid
2. Holddown Latch
3. Air Cleaner Housing

**NOTE:** Be careful not to bump the air filter element while it is in the housing; this can raise a cloud of dust that can enter the clean side of the piping to the turbocharger.

1. Unhook the holddown latches and remove the inlet lid from air cleaner housing. Remove the filter element carefully and slowly, then discard the old element.



2. Wipe the inside of the air cleaner housing with a clean, damp cloth. Be sure to clean the gasket sealing surface. Be sure to wipe out any dust that has fallen into the port to the turbocharger. **DO NOT** use compressed air for this cleaning!
3. Visually inspect the air cleaner housing for damage or distortion, which could allow unfiltered air to enter the engine. Inspect to be sure that the rubber dust unloader valve at bottom of housing is in place, free of debris, and not cracked.
4. Inspect the new air filter element for a damaged or nonresilient rubber gasket. Inspect the air filter element body for dents or excessive pleat bunching. If any of the mentioned conditions exist, obtain and install an alternate new air filter element from your International dealer.
5. Carefully install the new air filter element into the air cleaner housing.
6. Seat and install the inlet lid squarely onto air cleaner housing, hook and latch inlet lid to air cleaner housing with holddown latches.
7. When servicing is completed, reset air restriction gauge by pushing and holding the reset button and releasing

it. The yellow indicator will drop below the window. The air restriction gauge is now ready for the next operating cycle.

### Air Restriction Gauge Service

The initial restriction with a new air filter element will vary with air cleaner design and installation.

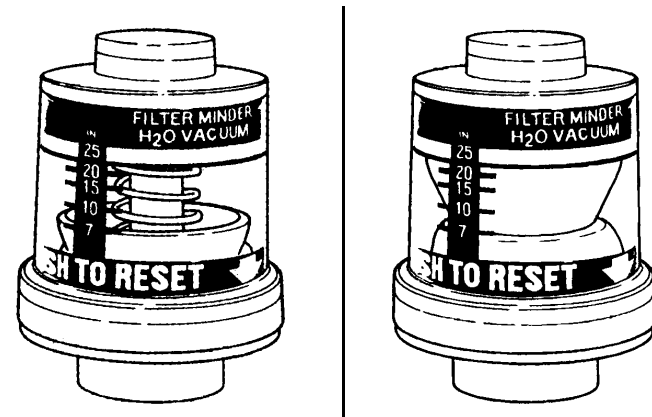

## Maintenance

---

### Troubleshooting

#### No Restriction Reading

POSSIBLE CAUSES	HOW TO CHECK
Plugged fitting or vacuum line	Apply vacuum to gauge until locked up at red zone. Re-connect line and hold in reset button. Indicator will fully return unless line or fitting is plugged. A slow return is normal due to safety filter in fitting.
Leak in vacuum line	Apply vacuum to gauge until locked up at red zone. Re-connect gauge and close end of line airtight. Hold in reset button. Indicator will drop slightly and then not move unless vacuum line has a leak.
Leak in gauge	Repeat above except close gauge connection airtight.
Engine air flow too low to generate a restriction reading	Turbocharged engines must be full load to pull full engine air flow (N.A. engines at full RPM).
Air cleaner element split open	Visually inspect element.

#### High Restriction Reading

POSSIBLE CAUSES	EXPLANATION
Plugged elements	Ultra fine particles are difficult to remove and cleaning may not sufficiently lower restriction.
Plugged inner element (if equipped)	Replace inner element.
Plugged inlet screens or ducts	Check system upstream from restriction tap for debris, damage, or improper installation.
Heavy snow or rain	Temporary high restriction can occur during a rain or snow storm and it disappears after drying out. COLD AIR MAY BE SO DENSE THAT HIGH RESTRICTION MAY NOT REDUCE ENGINE POWER BEFORE ELEMENTS ARE DAMAGED FROM HIGH VACUUM. If gauge is locked up at red zone check elements for damage.

## Chassis-Mounted Charge Air Cooler and Radiator Core Inspection and Cleaning

With the engine off, visually inspect the charge air cooler core and radiator core assembly for debris and clogging of external fins. Prior to engine operation, remove any debris blocking the core.

### Cooling System



To prevent personal injury or death, do the following when removing radiator or deaeration cap:

- Allow engine to cool for 15 minutes or more.
- Wrap a thick cloth around radiator cap or deaeration cap.
- Loosen cap slowly a quarter to half turn counterclockwise to vent pressure.
- Continue to turn cap counterclockwise to remove.



To prevent property damage, personal injury, and / or death, do not exceed the pressure rating on the deaeration tank cap. Ensure that the pressure rating of the deaeration tank cap matches that listed on the side of the tank, or the tank may burst.

### CAUTION

To prevent vehicle and / or engine component damage, observe the following. If the coolant should get extremely low and the engine very hot, let the engine cool for approximately 15 minutes before adding coolant; then, with the engine running, slowly add coolant. Adding cold coolant to a hot engine may crack the cylinder head or cylinder block. Never use water alone.

Make sure that coolant level is maintained between the COLD MIN and COLD MAX lines on the deaeration tank when engine is cold.

### Gravity-Fill Coolant Method

#### Filling Instructions

**NOTE:** If system has been drained, fill with fresh 50/50 diluted concentrate coolant or 50/50 pre-mixed coolant. If the system has been flushed with water, a significant amount of the freshwater flush will remain in the system. In this case, refilling with a mixture with a higher percentage (75%) of coolant concentrate is advised in order to achieve a final mixture close to 50/50.

**NOTE:** Using the KL5007NAV coolant management tool is the recommended procedure for filling the cooling system.. However, in some cases this tool may not be available, and the following gravity-fill procedure may be used instead. Contact an International dealer for special instructions on filling the coolant system.

## Maintenance

**NOTE:** This is a traditional gravity-fill-only method that involves pouring or pumping the coolant into the deaeration tank of the cooling system and using a combination of gravity and engine operation to purge the system of air. Depending upon your engine configuration, this method may include the disadvantage of a requirement to temporarily disconnect the EGR wiring harness to protect the EGR from heat damage prior to being completely deaerated (freed of trapped air). This process may generate a fault code that might require further investigation by an authorized International dealer.

For vehicles with Navistar's engines, see the following instructions on filling the cooling system.

1. Open any shutoff valve in heater circuit, in-transit heat circuit, or Auxiliary Power Unit (APU) circuit (not shown).
2. Open cooling system vent valve (where applicable) on top radiator pipe.
3. Fill deaeration tank with proper coolant to top of fill neck.
4. Close cooling system vent valve when air is purged and coolant is seen flowing from valve (where applicable).
5. Disconnect EGR valve electrical connector. For MaxxForce® 7 EGR location see MaxxForce® 7 engine left side view. For MaxxForce® DT, 9 EGR location see MaxxForce® DT, 9 engine left side view.

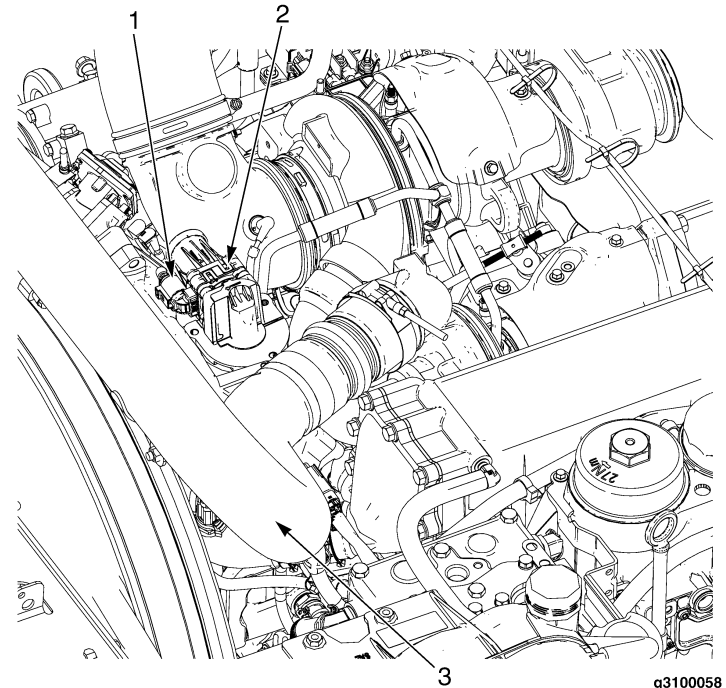

**MaxxForce® 7 engine left side view**

1. EGR Electrical Connector
2. EGR Valve
3. Charge Air Cooler Hose

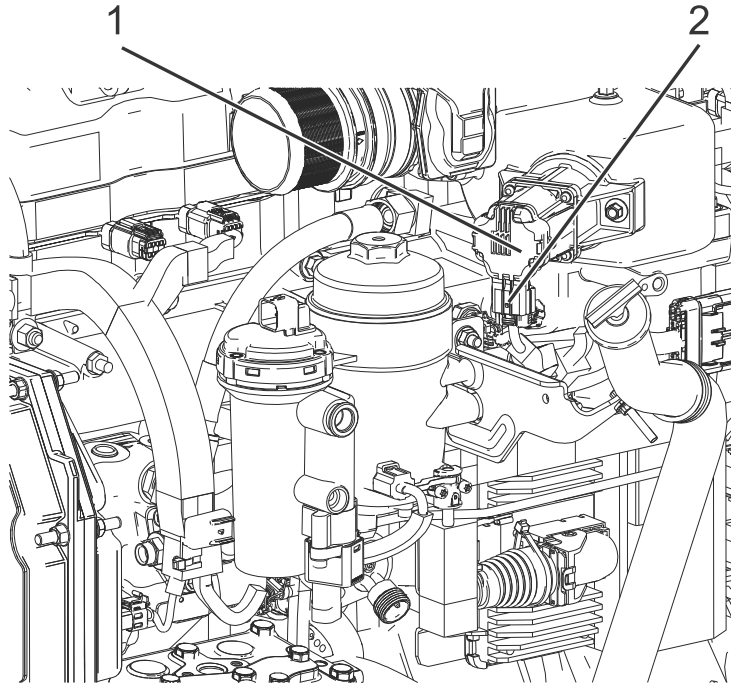

0000038374

### MaxxForce® DT, 9 engine left side view

1. EGR Valve
2. EGR Electrical Connector

6. To purge air from cooling system, start engine and run at an elevated idle (1,500 RPM) for approximately 10 minutes. Do not exceed 220°F (104°C).
7. Verify coolant concentration and adjust coolant level to MAX level.
8. Install deaeration tank cap (not shown) once coolant is stabilized at MAX level.
9. Turn off engine and connect EGR valve electrical connector.
10. Verify coolant is at correct level and concentration.
11. Clear fault code that was set when EGR valve was disconnected (consult IC Bus dealer).
12. Inspect and adjust coolant level as necessary, prior to daily operation.

## Maintenance

For vehicles with Cummins® ISB engines, see the following instructions on filling the cooling system.

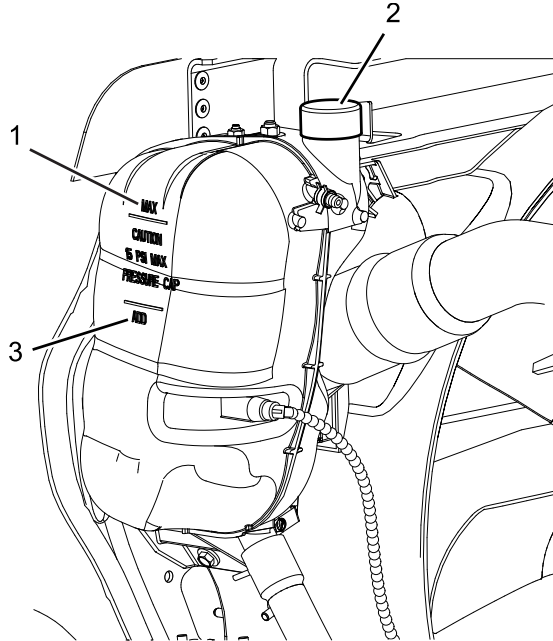

0000055766

**Typical Deaeration Tank for Cummins ISB Engine. (Yours may vary)**

1. COLD MAX Lines
2. Vented Fill Cap
3. COLD MIN (ADD) Line

To function properly, the coolant system must be completely filled with coolant and all air must be expelled. To accomplish this, the following procedures should be carefully completed:

1. Open the Heater Core Supply Cut-off Valve (Heater Cut-Off Valve, page 125) .
2. Close the Heater Core Return Cut-off Valve (Heater Cut-Off Valve, page 125).
3. Open the Heater Core Return Bleed Valve.
4. Fill the system to brimful in the Deaeration tank. Use a 50/50 mixture (75/25 if it has been flushed with water) of the proper coolant concentrate (refer to Lubricant and Sealer Specifications in section Maintenance Intervals and Specifications) and demineralized or distilled water into the deaeration tank. A 50/50 coolant mixture will achieve a -34°F (-37°C) freeze point. A 53/47 coolant mixture will achieve a -40°F (-40°C) freeze point. The first pour should reach to the top of the reservoir fill neck.
5. Turn on engine and operate at low idle.
6. Maintain coolant level above the add line as the bottle level draws down.
7. Increase engine speed to 1000 rpm.
8. Continue to operate the engine at 1000 rpm and maintain bottle level above the add line until the Heater Core Return Bleed Valve begins to purge fluid.
9. Return engine to low idle.
10. Close the Heater Core Return Bleed Valve.
11. Open the Heater Core Return Shutoff Valve.

12. Raise engine speed to high idle until coolant temperature reaches 190°F (88°C).
13. Continue operating engine for an additional five (5) minutes after coolant temperature reaches 190°F (88°C).
14. Return engine to low idle, allow engine to cool and shut down.
15. Top off coolant level to 1" above the max line on the Deaeration Tank.
16. Install Pressure Cap.
17. Let engine completely cool. Recheck coolant level and concentration / freeze point with a refractometer and top off as needed to achieve a coolant level at the COLD MAX line when cold.

### *Coolant and Optional Coolant Filter*

IC Bus, LLC recommends using only approved coolant with 2010 cooling packages, and will not warrant cooling systems that have not utilized the recommended coolant.

The label on the deaeration tank provides additional coolant / antifreeze information. Consult the Engine Operation and Maintenance Manual for coolant service life details.

Some engines are ordered with an optional coolant filter that should be replaced periodically.

For Ultra ELC equipped vehicles use only water filters **without** Supplemental Coolant Additives (SCA's) as SCA's are not necessary with Ultra ELC. Any time a silicone gasket / seal

exposed to the coolant is replaced while using Ultra ELC, a fresh charge of silicates must be added to the coolant to protect the new gasket / seal.

IC Bus, LLC recommends Ultra ELC due to its ease of maintenance and lower long-term cost of operation. Any system using or contaminated with more than 10% conventional coolant must be maintained like conventional coolant and receive regular tests for Supplemental Coolant Additive (SCA) levels.

### *Coolant Concentration / Freeze Point*

#### **CAUTION**

**To prevent property damage, always use Shell Rotella® Ultra Extended Life Coolant (ELC) or equivalent to top-off Ultra ELC-equipped cooling systems. Failure to do so may result in the loss of extended life properties. Should top-off occur with conventional coolant(s) exceeding 10% of the total cooling system capacity, drain and refill with Shell Rotella® Ultra ELC or an equivalent nitrite-free, heavy-duty ELC.**

Check the cooling systems twice a year to ensure proper coolant / water concentrations. A 53/47 coolant / water mixture from the factory provides freeze protection down to -40°C (-40°F) as well as excellent corrosion protection. A 50/50 mixture created in the shop using coolant concentrate and water or Shell Rotella® ELC Pre-Mixed coolant and will provide freeze protection down to -37°C (34°F) if no further dilution is experienced during installation.

## Maintenance

---

Concentrations more than 67% are not recommended. The use of ELC pre-mix to make up for coolant loss will conveniently ensure the glycol / water concentrations stay in balance.

### *Anti-Freeze*

For antifreeze coolant part numbers, capacities, and other antifreeze information, refer to the Engine Operation and Maintenance Manual.

### *Fan Clutch*

Inspect for proper operation, secure electrical connections, or air supply as appropriate. See the IC BE Bus Service Manual for details.

### **Heater and Coolant Hose Inspection and Replacement Guide**

Proper maintenance and inspection of the heater and coolant distribution system is required to maximize hose life, maintain performance of the system, and avoid potential failures.

Poorly maintained coolant is cause for hose failure. Coolant level and condition should be inspected on a regular basis.

- Check coolant level as part of the daily inspection.
- Check coolant concentration per coolant manufacturer requirements.

Heater and coolant hose inspections should be performed on an annual basis, or anytime a hose repair is made. To properly inspect engine and body heater hoses, protective metal or plastic covers and closeout panels are to be removed to allow

inspection of the complete heater and coolant / hose system. Once protective covers and closeout panels are removed, the following basic steps should be followed.

- Perform a visual and touch inspection of all hoses. Hose inspection process is to include all engine compartment and body, interior and under body, hoses.
- Check heater and coolant system for signs of cold and hot leaks.
- Pay attention to the hose ends and contact points that will typically show early signs of hose failure. Observe the area around all hoses for signs of leakage.
- Synthetic rubber can oxidize and harden over time. Squeeze the hose to make sure it is pliable. Entire hose length should have a consistent feel and appearance.
- Many times hoses will fail from the inside. A good-looking hose can fail due to deterioration of the inner hose and reinforcement. This type of deterioration can sometimes be detected during pressure testing.
- Cracks, blisters, or splits in the hose outer cover are the most visible signs of hose failure.
- Pressure test complete heater and cooling system annually. Test should be completed while performing hose inspection to allow all hoses to be observed for bulges and leaks.

Upon completion of the inspection process, reinstall all protective covers and closeout panels to original condition.

Many factors influence hose life such as location, years in service and service environment. Heater and coolant hose replacement is recommended after 5 years of service. In the



event a hose failure is experienced prior to the recommended replacement time frame, age and condition of remaining hoses should be considered to determine if all engine and body hoses should be replaced to reduce the potential for additional failures.

### Frame and Optional Tow Hooks

The Bus Chassis are manufactured with frame rails of High Strength Low Alloy (HSLA) steel and must be handled in a specific manner to ensure maximum service life. Specific instructions are published concerning proper repair of frame rails. Before attempting frame repair or modification, consult the service manager of your IC Bus, LLC dealer.

Inspect front and rear tow hooks for damage or loose mountings.

### Fuel System



**GOVERNMENT REGULATION: Diesel fuel sold for use in 2007 and later highway vehicles must be limited to a sulfur content of 15 parts per million (ppm).**



**To prevent property damage, personal injury, and / or death, never overfill the fuel tank. Overfilling the tank could cause fuel spillage and / or increased pressure inside the fuel tank. Pressure in an overfilled tank may cause leakage in the fuel system, which could result in a potential fire / explosive hazard.**

Frequently inspect condition of fuel tanks and mounting hardware, fuel tank cap and vent, fuel lines, clips and routing. Periodically drain water and sediment from the bottom of the fuel tank via the drain plug on the bottom of the fuel tank.

See the Engine Operation and Maintenance Manual service intervals for fuel filter water trap draining, fuel strainer draining and fuel filter replacement.

#### *Fuel Tank Draining and Cleaning*

Periodically (annually is recommended) drain water and sediment from the fuel tank via the drain plug on the bottom of the fuel tank. Drain and flush sediment from fuel tank at least every 12 months or more frequently if fuel quality or type of fuel dictates.

Since Ultra-Low Sulfur Diesel (ULSD) fuel tends to absorb more water and engines are operating at higher temperatures, microbe growth in the fuel tanks has become more prevalent. Microbe growth results in more contaminants in the fuel and reduces fuel filter life. Since fuel tank draining does not remove all microbes, fuel tank draining alone will not eliminate the

## Maintenance

---

problem. For vehicle operators experiencing microbe growth in their fuel, the following is recommended:

1. Drain and clean the fuel tank(s) every 12 months or more often. Clean the tanks with a professional fuel tank cleaning system (available through your IC Bus, LLC dealer) or have your local IC Bus, LLC dealer perform the service for you.
2. Treat your vehicle fuel tanks and bulk tanks regularly with a biocide from a reputable vendor.
3. Purchase fuel only from vendors which you know pretreat their fuel with biocides.
4. Periodically, test the fuel supplied by your fuel vendor for the presence of microbes.

### Heater System

Check all heating / cooling fans for operation. ensure Heater cut-off valves are opened / closed during appropriate cold / warm months for greatest passenger comfort. Maintain heat exchanger air filters (if equipped). The driver's heater filter is

located behind the grill near the floor, to the left of the driver's seat. The optional step well heater filter is located behind the grill to the front of the step well. Under seat heaters may have an optional filter on the top surface of each heater box.

Heater booster pumps should not be run dry for more than 30 seconds. This may cause the seals to fail.

### Integrated Air Conditioning (IC Air) System

The following conditions require the immediate attention of your nearest authorized IC Air Service Center.

- Vibration and / or noise from engine compartment
- Oil around refrigeration hose connections
- Water dripping from evaporator and / or air ducts
- Vibration and / or noise from the evaporator area
- Noticeable decrease in system performance
- Reduced air flow (this condition is normally a result of dirty or clogged evaporator filters).

### Drive Shaft

At the regular lubrication interval, check universal joints, slip joint, slip joint boot, and carrier bearings for any evidence of wear or looseness.

### Suspension (Air and Steel Springs)

#### CAUTION

**To prevent vehicle and / or engine component damage, do not adjust air suspension height to any setting other than the specified setting. Altering the height setting will change the driveline angle and may result in unwarrantable component damage, such as transmission component damage.**

Periodically verify driveline axle air suspension height and height control valve performance. Refer to the LUBRICATION AND MAINTENANCE INTERVAL CHART at the end of this section.

Periodically:

- Check condition of spring leaves for evidence of fatigue, bending or breakage.
- Check condition of suspension mounting brackets and bushings.
- Check that torque rod mounting fasteners are tight.

**NOTE: When retorque is required, make sure the part is in like new condition. If it can't be retorqued, then the part needs to be replaced.**

Suspension alignment must be maintained at all times.

Check the U-bolts as follows:

- After the bus has been operating under load for 1,600 km (1,000 miles), retorque the U-Bolt nuts.
- Thereafter, retorque the U-bolt nuts every 58,000 km (36,000 miles).
- Clean and lubricate the U-Bolt, nut threads, and seats to ensure a like new condition when retorquing.

### Steering

#### General



**To prevent property damage, personal injury, and / or death, always follow recommended procedures for steering system maintenance. Failure to maintain the steering system in proper condition can cause reduced steering ability.**

**NOTE: Steering problems must be corrected at once by a qualified mechanic.**

#### Inspect the steering system:

- Check tie rod ends, drag link ends and kingpins. Joints and fasteners must be tight. Articulating joints must be well lubricated.

## Maintenance

---

- Check for installation and spread of cotter pins and tightness of nuts at both ends of tie rod and drag link.
- Check that pitman arm (steering arm at steering gear) mounting is tight and locked. Check the power steering system for leaks or hose chafing. Repair at once.
- Maintain proper power steering fluid level.
- Regularly inspect steering column joint bolts and steering linkage, particularly for body-to-chassis clearance.

### Tightening Steering Intermediate Shaft Joint Bolts

Check the steering intermediate shaft joint bolts for tightness every 96,000 km (60,000 miles) or annually, whichever occurs first. Tighten bolts to torque specified in the TORQUE SPECIFICATION CHART at the end of this section. DO NOT OVER-TIGHTEN.

### Lubrication Points

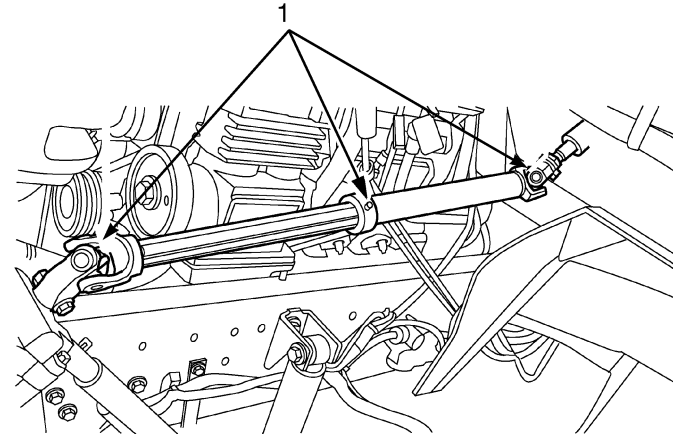

3813021

### Typical steering shaft

#### 1. Lubrication Points

The steering shaft is lubricated at the three points shown above. For the correct maintenance interval, refer to the LUBRICATION AND MAINTENANCE INTERVAL CHART at the end of this section.

### Power Steering

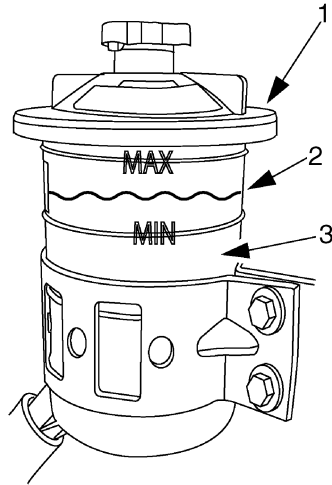

3813022

### Power Steering Reservoir

1. Filter Access Cap
2. Fluid Level
3. Internal Power Steering Fluid Filter

Periodically replace the power steering fluid.

Whenever the hydraulic (power steering) system has been drained and refilled, bleed air from the system before returning the vehicle to service. Failure to properly bleed the hydraulic system can result in shimmy complaints and / or steering wheel oscillation when striking a bump.

Consult your IC Bus, LLC dealer or IC Bus, LLC Service Manual for the proper procedures for filling and bleeding the system.

The power steering fluid filter is located inside the power steering reservoir. To remove the filter, unscrew the large cap on the power steering reservoir and unscrew the filter. Reverse the procedure to install the new filter.

Refer to the LUBRICATION AND MAINTENANCE INTERVAL CHART at the back of this section for the fluid and filter replacement intervals.

### DEF Tank Filling

#### CAUTION

To prevent vehicle and / or engine component damage, proper care should be taken when handling, dispensing, or transporting DEF, as it is corrosive to some metals and materials.

#### CAUTION

To prevent your engine from being de-rated due to DEF contamination and / or loss of DEF purity, before using containers or funnels that will be used to dispense, handle, or store Diesel Exhaust Fluid (DEF), make certain to wash thoroughly to remove any contaminants and then rinse with distilled water. **DO NOT USE TAP WATER** to rinse components that will be used to store or deliver DEF fluid. If no distilled water is available, rinse with tap water and then rinse with diesel exhaust fluid (DEF).

The DEF tank filler cap is located on the right side of the vehicle behind an appropriately labelled access door. The DEF filler cap on this vehicle is blue in order to differentiate it from the fuel filler cap. Use only ISO 22241-1 approved DEF to ensure proper purity and concentration.

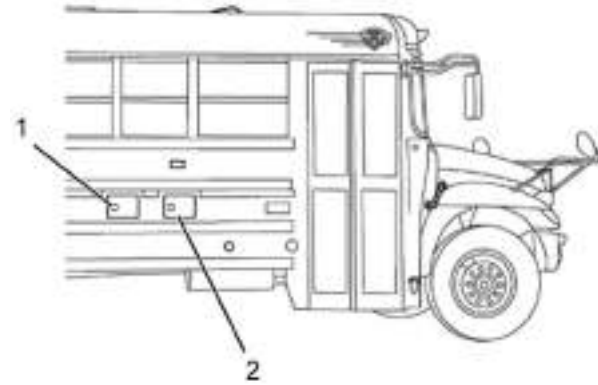

600005775

**Typical BE / CE Bus Fuel and DEF Access Door Locations.  
(Yours may vary)**

1. Fuel Access Door
2. DEF Access Door

## Exhaust Diesel Particulate Filter (DPF)

### Regeneration

Collected soot particles in the Diesel Particulate Filter (DPF) are automatically burned off through normal regeneration (initiated by normal exhaust heat during the normal operation of the vehicle). If conditions for normal regeneration cannot be achieved, it may be necessary to perform a parked regeneration as indicated by the Instrument Panel Gauge Cluster warning indicators. See the Parked Regeneration Procedure in **SECTION 9 — DRIVING**.

### Cleaning

If on-vehicle regeneration is unsuccessful at removing soot from the DPF, the DPF may need to be removed from the vehicle and be cleaned with the appropriate machinery and processes.

Ash residue in the DPF comes primarily from fuel and oil additives and will not burn or pass through the DPF. Ash residue accumulates very slowly in the DPF, but must eventually be removed to prevent excessive exhaust backpressure. If the DPF needs to have nonregenerable soot or the ash residue removed, please take the vehicle to an IC Bus, LLC dealer.

## Transmission

### Transmission Fluid Level

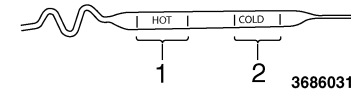

1. Hot Fluid Level
2. Cold Fluid Level

- Check fluid level with the parking brake applied, the engine running at idle speed, and the transmission in neutral. Consider the transmission fluid temperature when determining the correct level.
- When the transmission fluid is cold, the fluid level should fall within the COLD run band. When the transmission fluid is hot, the fluid level should fall within the HOT run band. Add fluid as required. DO NOT OVERFILL or the transmission will overheat.
- Check the shift linkage for proper operation.
- Check operation of transmission neutral safety switch. Try to start the vehicle in all shift selector positions. The starter should ONLY operate when the shift selector is in Neutral, or Park, if supplied.

## Maintenance

---

- Refer to the LUBRICATION AND MAINTENANCE INTERVAL CHART and the LUBRICANT AND SEALER SPECIFICATIONS chart at the end of this section for information on automatic transmission fluids and fluid and filter change intervals.

### Tires

#### Tire Warnings



To prevent property damage, personal injury, and / or death, for field maintenance, only inflate and load tires to the maximum of the least-rated tire on the axle. Due to tire manufacturers re-marking tires to conform to the SI (metric) system, tires marked with old and new loads or inflation pressures could be placed on the same vehicle.



To prevent property damage, personal injury, and / or death, always maintain your tires in good condition. Frequently check and maintain correct inflation pressures as specified by tire manufacturers. Inspect periodically for abnormal wear patterns and repair / replace cut or broken tire casing. Always use experienced, trained personnel with proper equipment and correct procedures to mount or remove tires and wheels.



**To prevent property damage, personal injury, and / or death, always follow these instructions when mounting tires on wheels:**

- Only personnel who have had proper training and experience should mount or remove tires from rims or wheels.
- Use only heavy-duty rims or rims approved for radial tires. It may be necessary to contact your wheel and rim distributor to determine if your rims are approved for radial tires.
- If a tube is to be used, make sure special radial tire tubes are used because of the increased flexing of the sidewalls on radial tires.
- Never use antifreeze, silicones, or petroleum-based lubricants when mounting radial tires. Only an approved lubricant should be used as an aid for mounting tires.
- Always inflate tires in a safety cage.





To prevent property damage, personal injury, and / or death:

- Do not mix stud-piloted wheels or fasteners with hub-piloted wheels or fasteners. Mixing wheel types may cause premature wheel failure.
- Do not change from steel wheels or a steel inner and aluminum outer wheel combination to aluminum wheels without changing the mounting hardware since the thicker aluminum wheels require longer studs. In some cases with flange nut mounting systems, changing the hub and stud assembly may be required. Improperly mixing components could cause wheel or fastener failures.
- Do not mix foreign (not made in North America) wheel mounting parts with domestic (made in North America) parts. Many foreign wheel components look similar to, but are not exactly the same as, domestic made components. Mixing components can cause wheel or fastener failures.



To prevent property damage, personal injury, and / or death, do not mount tube-type tires on tubeless wheels or tubeless tires on tube-type wheels.

### **Tire Maintenance**

Preserving proper inflation pressure is a very important maintenance practice to ensure safe vehicle operation and long life for the tires.

Failure to maintain correct inflation pressure may result in sudden tire destruction, improper vehicle handling, and may cause rapid and irregular tire wear. Therefore, inflation pressures should be checked daily and always before long-distance trips.

Follow the tire manufacturer's recommended cold inflation pressure for the tire size, type, load range (ply rating), and axle loading typical for your operation. (Each steer axle tire load will equal 1/2 steer axle loading. Each drive tire load will be 1/4 the axle loading, if fitted with four tires.)

#### *Checking Inflation*

Always check inflation pressure when tires are cold. Never bleed air from hot tires to relieve normal pressure buildup. Normal increases in pressure during operation will be 69 to 103 kPa (10 to 15 psi), which is allowable in truck tires. Tires on the same axle should have the same air pressure as the corresponding other tire(s) on that axle. Steer tires should be within a 21 kPa (3 psi) pressure range. All drive tires should be within a 5-psi pressure range. Tag or pusher axle tires on the same axle should be within a 34 kPa (5 psi) pressure range.

To minimize rim corrosion, it is particularly important to keep moisture from the inside of tires and proper selection of air compressor equipment, proper air line routing, and the use of

## Maintenance

---

shop air dryers is strongly recommended to avoid moisture in the high-pressure air used for tire inflation.

### *Underinflation*

Tires should not be permitted to become underinflated. Increased flexing due to underinflation causes heat buildup within the tire components. This leads to reduced strength, breakdown of the rubber compounds and possible separation of the tire components (such as ply and tread separation and reduced retreadability).

Underinflation is also the primary cause of blowouts. In addition, low inflation causes an increase in rolling resistance. This results in reduced fuel mileage, a loss in tread life, and uneven wear due to increased tread movement. To determine proper inflation, refer to the tire inflation range stated on the tire sidewall and the tire manufacturer's tire load-pressure charts.

### **Inspection**

Check condition of tires for abnormal wear patterns and proper inflation pressures. Cut or broken tire casing must be repaired or replaced.

Tires should be inspected for the following conditions. If any are present, the tire should be removed and repaired, retreaded, or scrapped as the condition indicates.

- Any blister, bump, or raised portion anywhere on the surface of the tire tread or sidewall (other than a bump made by a repair). These indicate the start of internal separation.
- Any cut that reaches to the belt or ply cords or any cut that is large enough to grow in size and depth.

- Any nail or puncturing object.
- If any stone or object is held by a tread groove and is starting to drill into the tread base, remove the object.

Proper tire inflation, toe-in adjustment, loads, and road speeds are important factors governing tire life, steering ease, maneuverability, fuel economy, and ride quality.

### **Loads**



**To prevent property damage, personal injury, and / or death, do not load tires beyond their rated capacity as this decreases tire life, requiring more frequent replacement of tires. Overloading creates an unsafe condition that may result in sudden air loss from a tire failure resulting in an accident.**

**NOTE: The load rating of the tires installed on your vehicle at the time of your vehicle's production is at or in excess of the Gross Axle Weight Rating (GAWR) generally found on a label on the bulkhead above the driver. When replacing tires, be sure that the replacement tire load rating (listed separately in pounds and kilograms on the tire sidewall for single or dual applications) multiplied by the number of tires on that axle is equal to or higher than the specific listed Steer Axle or Drive Axle GAWR. Failure to do so will adversely affect maximum load-carrying capacity. Tires with the same size specification do not always have the same load specification.**

### Dual Tires Matching

Dual tires should be matched using tires of equivalent size. Tires which differ more than 6 mm (1/4 in) in diameter or 19 mm (3/4 in) in circumference should not be mounted on the same dual wheel assembly.

### Dual Tires Mixing

**NOTE: Never mix bias and radial tires on this vehicle.**

It is recommended for best overall performance that only radial tires be used on this vehicle.

Never mix different tire sizes or constructions on the same axle.

### Rotation

- Steer tires that have developed some type of irregular wear pattern can be rotated to drive axles if rib tires are being used on all wheel positions. Applying steer tires to a drive position will often wear off the irregularities and they can be moved back to the steer axles or run out to retread stage on the rear axle.
- Another rotation possibility for fleets with rib tires in all wheel positions is to break in the new steer tires in the drive axle positions, then move them to steer axles. This will wear away tread rubber relatively quick in the early life of a tire when it is most likely to develop an unusual wear pattern.
- Drive axle tires may be placed on the other end of the same axle so that direction of rotation is reversed. This is often helpful if a heel and toe or alternate wheel nut wear pattern has developed.

### *Rotation Is Advisable*

1. If front (steering) axle tires become irregularly worn, move to rear position.
2. In a dual assembly, reverse the position of the tires if one tire wears much faster than its mate.
3. On the drive axle, if heel and toe wear or alternate wheel nut wear occurs, rotating the tires from one end of the axle to the other end of the axle may help even out this wear.

### *Tire Replacement*

**NOTE: Retread tires are not recommended for use on steering axles of trucks.**

- **Front (Steering) Axle - Tires must be removed when tread is worn to 3 mm (4/32 in) or less. Retread or rotate worn tires to drive position.**
- **Rear Axles - Tires must be removed when tread is worn to 2 mm (2/32 in).**

**If rib tire is used on front axle and lug- or off-road-type on rear axle positions:**

- **Front (Steering) Axle - Replace tires at front wheels when tread is worn to 3 mm (4/32 in) or less.**
- **Rear Axles - Tires must be removed when the tread is worn to 2 mm (2/32 in) or less. Tires identified with the word regroovable molded on the sidewall can be regrooved. A minimum of 2.38 mm (3/32) of undertread must be left at the bottom of the grooves.**

### Wheel and Tire Balancing

Out-of-round or out-of-balance wheels or tires can cause vehicle vibration and bounce, and shimmy. Replace damaged or out-of-round wheels. Out-of-round tires and wheel assemblies can be corrected by rechecking the tire relative to the wheel. The tire and wheel assembly should thereafter be dynamically balanced and reinspected while spinning for an out of round condition.

### Wear

Radial tires can exhibit three types of normal wear patterns, even, erosion, or chamfer.

**Even Wear** is a sign that the tire is being properly used and maintained.

**Erosion Wear** has also been called rolling wear, channel, or river wear. Erosion wear is found more often at free rolling tires. This is an indication that the tire is being used in a slow wearing operation. What happens is that the belt plies are held very rigid and the tread is not allowed to distort as it passes through the contact area. Wear will only occur at the edge of the tread. No corrective action required. If erosion gets to be 2 mm (1/16 in) or more, the tire may be rotated to a drive axle.

**Chamfer or Shoulder Wear**, with tires inflated properly, is a normal tendency of most radial tire designs. If both inside and outside shoulders are wearing evenly around the tire, no further action is required. Overinflation is not effective in correcting this effect.

### *Irregular Wear*

If irregular wear is present, check the axle alignment, tire pressure, wheel balance, shock and suspension component condition, and wheel bearing end play.

This condition not only shortens tire life, but will adversely affect the handling of your vehicle.

Rotating tires from one wheel position to another is a way often used to even out many types of irregular wear or to avoid it altogether. See **Tires – Rotation** for more information. Some of the more effective tire rotation programs are:

#### **Irregular wear can be minimized by:**

- Using the right inflation pressure for the load being carried.
- Maintaining proper front wheel alignment - **especially toe-in** - to specifications.
- Maintaining proper tire and wheel balance.
- Maintaining shock absorbers and suspension components.
- Maintain proper wheel bearing adjustment .

### **Use of Tire Chains**

Refer to chain manufacturer's recommendation for correct tire chain usage, installation, and removal.

## Wheels

### Wheel and Wheel Nut Maintenance and Installation



To prevent property damage, personal injury, and / or death, always follow these instructions when mounting tires on wheels:

- Only personnel who have had proper training and experience should mount or remove tires from rims or wheels.
- Use only heavy-duty rims or rims approved for radial tires. It may be necessary to contact your wheel and rim distributor to determine if your rims are approved for radial tires.
- If a tube is to be used, make sure special radial tire tubes are used because of the increased flexing of the sidewalls on radial tires.
- Never use antifreeze, silicones, or petroleum-based lubricants when mounting radial tires. Only an approved lubricant should be used as an aid for mounting tires.
- Always inflate tires in a safety cage.



To prevent property damage, personal injury, and / or death:

- Do not mix stud-piloted wheels or fasteners with hub-piloted wheels or fasteners. Mixing wheel types may cause premature wheel failure.
- Do not change from steel wheels or a steel inner and aluminum outer wheel combination to aluminum wheels without changing the mounting hardware since the thicker aluminum wheels require longer studs. In some cases with flange nut mounting systems, changing the hub and stud assembly may be required. Improperly mixing components could cause wheel or fastener failures.
- Do not mix foreign (not made in North America) wheel mounting parts with domestic (made in North America) parts. Many foreign wheel components look similar to, but are not exactly the same as, domestic made components. Mixing components can cause wheel or fastener failures.



**To prevent property damage, personal injury, and / or death, when installing the tire and rim assembly on disc brake-equipped axles, make sure the tire valve stem clears the brake caliper. The use of either an International® truck valve stem retainer or a tire manufacturer's stem forming tool is the only acceptable method of obtaining clearance when necessary. Failure to obtain proper clearance may result in rapid tire deflation.**

### *Wheel Nut Torque Maintenance*

Tighten and maintain wheel and rim mounting nuts to the proper torque. Loose nuts or overtightened nuts can lead to premature wear and possible failure of the wheel, rim, and / or mounting hardware.

### *Hub-Piloted Wheel Installation Procedures*



**To prevent property damage, personal injury, and / or death, use only the same type and style wheels and mounting hardware to replace original parts. Failure to do so may result in an assembly that looks fine but does not fit together properly. This could cause wheel or fastener failures.**

Out-of-round tires and wheel assemblies can sometimes be corrected by reclocking the tire relative to the wheel.

Tightening procedure for disc wheels with flange nuts (hub-piloted).

1. Clean the mating surfaces of the hub, drum, and wheel(s) as well as the wheel studs and wheel nuts with a wire brush prior to assembly.
2. Lubricate, the two-piece wheel nuts by putting two drops of oil in the slot between the nut and washer and spin the washer to spread the oil around the nut-to-washer contact surface.
3. Carefully lubricate the wheel stud threads by wiping them with a freshly oiled cloth. Do not get the oil on any other surfaces or the wheel clamping effectiveness will be reduced!
4. To prevent aluminum wheels from getting stuck on the hub due to corrosion, apply a thin coat of antiseize compound or disc brake corrosion control grease to the hub pilot pads only.
5. Slide the inner wheel (if duals) or steer wheel over the wheel studs and onto the pilot pads of the hub. Care must be taken to avoid damage to the stud threads while positioning the wheel. Ensure that the wheel is resting on the pilot pads and is against the brake drum.
6. Hand-start all wheel nuts to avoid cross-threading.
7. Starting with the nut at the 12 o'clock position and using the appropriate star or crisscross pattern (see wheel nuts torque sequence diagram), run the wheel nuts down the

wheel studs with an impact wrench until they are snug against the wheel. The purpose of this step is to snug the wheel(s) in the correct position, not to apply the final torque. The tightening of each nut should be stopped immediately when the wheel is contacted, resulting in a wheel nut torque well below the final specified torque.

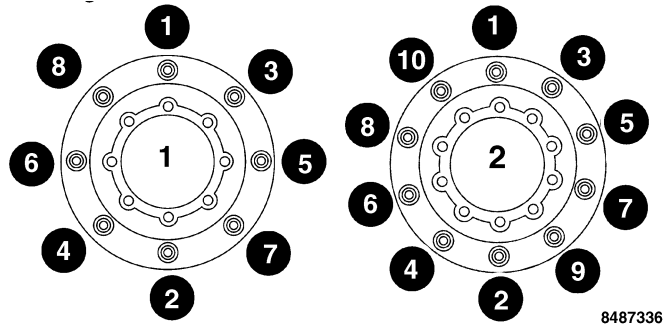

8487336

1. Flange Nut Mount – 8 Stud
  2. Flange Nut Mount – 10 Stud
8. Use a calibrated torque wrench to apply the specified torque to each wheel nut in the sequence specified in the wheel nuts torque sequence diagram above. Refer to **MAINTENANCE INTERVALS AND SPECIFICATIONS** for proper torque values.
  9. All wheels undergo a process called joint settling when placed in service after a wheel installation has been

performed. This process results in a reduction in the torque on the wheel nuts. To correct this condition, operate the vehicle normally for approximately 80 km (50 miles), then use a calibrated torque wrench to retorque the wheel nuts to specification using the appropriate pattern shown in the wheel nuts torque sequence diagram.

10. As part of a daily pretrip inspection, look for loose or missing wheel nuts. Also look for rust streaks extending outward from the wheel nuts; this can be an indicator that one or more wheel nuts are loose, even if they cannot be turned by hand. Normal periodic maintenance should also include checking the wheel nut torque with a torque wrench.

## Windshield Wiper

### Wiper Blade Assembly Replacement

1. Press the plastic lever at the wiper blade assembly to the wiper arm hinge.
2. Slide the wiper blade assembly up the wiper arm and detach it.
3. Snap the new wiper blade assembly on to the arm in the opposite direction of the removal.
4. Check to see that the rubber wiper blade rests flat against the windshield.

### Wiper Arm Removal / Replacement

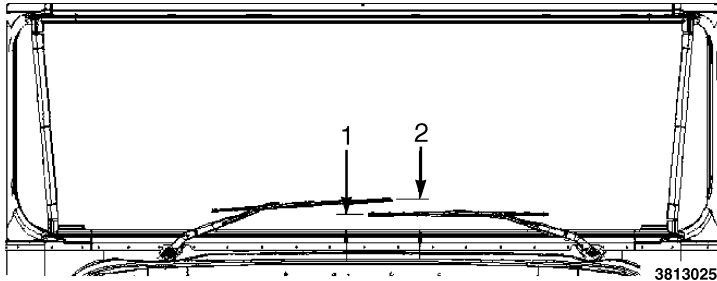

1. Driver Side Measurement (2.06 in. +12 in. -20 in.)
2. Passenger Side Measurement (3.98 in. -12 in. +20 in.)

Turn the windshield wiper switch to the on position. Allow wipers to complete a full cycle and turn off the switch. Wipers should stop in the parked position.

#### Removal

1. Locate and disconnect the wiper / washer supply hose from the supply port on the cowl.
2. With the wipers in the parked position, place a mark on the base section of the wiper arm assembly. Make a corresponding mark on the boot covering the drive mechanism.

3. Locate and remove the plastic cap cover at the wiper arm base.
4. With the cap removed, loosen and remove the nut securing the wiper arm to the drive stud. Remove the wiper arm from the drive stud by pulling the wiper arm outward.

#### Installation

1. Align the marks at the base of the wiper arm assembly and the drive stud boot.
2. Install the wiper arm on the drive stud. Confirm the correct height of each wiper from the base of the windshield per the figure shown.
3. Place the wiper arm retaining nut on the drive stud and tighten. Refer to the TORQUE CHART at the end of this section for correct torque specification.
4. Replace the plastic cap on the wiper arm assembly covering the attachment nut.
5. Reconnect the wiper / washer supply hose on the cowl.
6. Operate the windshield wipers and washer to verify correct operation. If wipers contact each other or the window frames during operation, or if they look close and might contact each other or the windshield frame, adjust the wiper arm orientation as needed.



### Maintenance Intervals

All new vehicles are factory-lubricated. Once the vehicle is in operation, regular lubrication and maintenance intervals (based on the type of service and road conditions) must be established and performed. Load weight, vehicle speed, road conditions, and weather conditions all contribute to lubrication frequency. Performing thorough lubrication and maintenance at the specified intervals will ensure an outstanding vehicle life and will reduce overall operating expense.

The LUBRICATION AND MAINTENANCE INTERVAL CHART contains an extensive list of components and systems. Listed items and systems must be regularly inspected, serviced, and / or replaced to maximize vehicle availability and minimize unexpected failures. Recommended synchronized intervals are shown for each item. This chart can serve as a convenient one-stop reference to research most maintenance needs.

Only lubricants of superior quality, such as Fleetrite® lubricants, should be used. The use of inferior products will reduce the service life of the vehicle or result in failure of its components. The use of Fleetrite® lubricants is recommended for optimum performance.

Maintenance intervals provided in this manual are for normal highway and environmental service conditions.

These intervals may be expressed in miles (kilometers), hours of operation, and / or months of operation. It is important to note

that in high duty cycle types of operation and / or where operating conditions are extremely severe (such as in deep water, mud or unusually dusty conditions), the vehicle may require lubrication much more frequently than specified in this manual.

The synchronized A and B service intervals are designed to coordinate maintenance activities and to provide the appropriate levels for servicing components. Following the service intervals minimizes the number of times per year that the vehicle must be brought into the shop. In addition to the A and B service intervals, the Special Service Interval column is provided for items that need infrequent servicing. In most cases, these service intervals represent the recommended maximum intervals. For some components, however, the manufacturer's recommended maintenance intervals may have been shortened to allow synchronization with other maintenance tasks.

The maintainer may wish to synchronize engine related items with other lubrication / maintenance intervals in order to reduce downtime, even though the recommended intervals in the Engine Manual may be longer. **Engine Manual maximum intervals (based on the actual operating conditions specified in that manual) must never be exceeded.**

**NOTE: For vehicles equipped with Cummins ISB® engines, refer to Cummins QuickServe® Online, your Cummins Engine Operation Manual, or contact a certified Cummins repair location for specific engine maintenance intervals, capacities, and instructions.**

## Maintenance

---

### Lubrication and Maintenance Interval Chart Symbols Key

Table 13

Symbol	Interval Definition
A	A interval: 16,000 km (10,000 miles) / 300 hours / 6 months
B	B interval: 32,000 km (20,000 miles) / 600 hours / 12 months

### Lubrication and Maintenance Interval Chart Notes

Table 14

**NOTE 1:** A hand-pumped grease gun should be used for optimal grease distribution within the component joint.

**NOTE 2:** Kingpin thrust washers must be lubricated with vehicle weight on tires. Kingpins and kingpin bushings must be lubricated with weight off of the wheels and tires.

**NOTE 3:** Certain services are performed at Special Intervals or in addition to A or B Service when the interval dictates.

**Lubrication and Maintenance Interval: Bus — Recommended Synchronized Intervals**

System	Item	Intervals	Special Interval (3) : km (miles) / hours / months
Pre-Trip Inspection	Pre-trip Inspection Items listed in Section 2 – Check All		
Front Axle	Wheel Bearing-Oil Type – Check Level	A, B	
	Suspension Fasteners / Components – Check	A, B	
	Tie Rod Ends – Lubricate (1)	A, B	
	Drag Link – Lubricate (1)	A, B	
	Kingpins and Bushings – Lubricate (1,2)	A, B	
	Shock Absorbers – Inspect	A, B	
	Axle U-bolts – Retorque		At first 1,600 km (1,000 miles) then every 58,000 km (36,000 miles) thereafter
	Wheel Bearing-Grease Type – Repack		48,000(30,000) / – / 6
	Wheel Bearing-Oil Type (including synthetic) – Change Oil		96,000(60,000) / – / 6
	Wheel Bearings – Check End-play	B	
Electrical	Engine Start and Gauge / Warning Lights – Check	A, B	
	Instrument Readings Proper – Check	A, B	
	ABS Wiring Connections & Sensors - Reseat	A, B	
	Alternator-Starter-Battery – Check	B	
	Electrical lines routing and clipping (lines are not tangled, crimped or pinched or rubbing against surfaces); not spliced or taped; insulation not cut, cracked, chafed or worn. – Inspect	B	
	Power Distribution Center: Corrosion throughout case and on pins of fuses and breakers – Inspect	B	

## Maintenance

### Lubrication and Maintenance Interval: Bus — Recommended Synchronized Intervals (cont.)

System	Item	Intervals	Special Interval (3) : km (miles) / hours / months
Steering	Power Steering Fluid – Check Level	A, B	
	Steering System – Check Tightness	A, B	
	Steering Gear – Lubricate	A, B	ATTN: Install grease slowly at low pressure. Power grease guns may blow out seals.
	Steering Intermediate Shaft U-Joints / Slip Joint – Lubricate	A, B	
	Power Steering Fluid – Change		64,000(40,000) / – / 12
	Steering Intermediate Shaft U-Joints – Retorque		80,000(50,000) / 1,500 / 24
	Power Steering Filter – Replace		800,000(500,000) / 1,500 / 60
Drive Shaft SPL	U-Joints – Lubricate; Slip Joint Boot – Inspect	B	
Drive Shaft Non-booted Slip Joint	U-Joints and Slip Joint – Lubricate		8,000(5,000) / – / 3
Brakes – Air	Air Wet Tank – Drain Water	A, B	
	Service Brakes Operation – Check	A, B	
	Parking Brake Operation – Check	A, B	
	Governor Cut-in / Cut-out Pressure – Check	A, B	
	Low Air Pressure Warning Alarm – Check	A, B	
	Air Tanks (all) – Drain Water	A, B	
	S-Cam Bushings – Lubricate	A, B	
	Shoes – Check for wear and drag	A, B	
	Rotors / Drums, Calipers, Chambers, Hoses, etc – Check for wear / damage	A, B	
	Brake Chamber Rod Travel – Check	A, B	

**Lubrication and Maintenance Interval: Bus — Recommended Synchronized Intervals (cont.)**

System	Item	Intervals	Special Interval (3) : km (miles) / hours / months
	Air Dryer Desiccant – Replace		AD-9 Model: 400,000 km (250,000 miles) / - / 24 Other Models: 200,000 km (125,000 miles) / - / 12
	Air Dryer Heater & Purge Valve – Check		AD-IP: 12; AD-9: 24
	Air Compressor Discharge Line – Check blockage		80,000(50,000) / 1,500 / 24
Hydraulic Full Power Brakes	Master Cylinder – Check Fluid Level	A, B	
	Master Cylinder Cap – Check Vent for Obstruction	A, B	
	<b>NOTE: If obstruction is observed, replace cap.</b>		
	Brake Pedal Holds Pressure– Check	A, B	
	Brake Pedal Holds Pressure – Check	A, B	
	Service Brakes Operation – Check	A, B	
	Parking Brake Operation – Check	A, B	
	Discs, Calipers, Lines, etc – Check for wear / damage	A, B	
	Parking Brake Cable – Check condition	A, B	
	Accumulators – Replace		At Instrument Cluster Light Indication or 12 years
Cooling System	Coolant – Check Level	A, B	
	Radiator & CAC Fins – Check for Blockage	A, B	
	Fan Clutch – Check	A, B	
	Fan Blade / Shroud – Check Damage / Contact	A, B	
	Coolant Filter (if equipped) – Replace		241,000(150,000) / 6,000 / 30
	Extended Life Coolant – Add Extender		V8 and I6: 241,000(150,000) / 6,000 / 30
	Extended Life Coolant – Replace		V8 and I6: 483,000(300,000) / 12,000 / 60

## Maintenance

### Lubrication and Maintenance Interval: Bus — Recommended Synchronized Intervals (cont.)

System	Item	Intervals	Special Interval (3) : km (miles) / hours / months
Engine	<b>NOTE: For vehicles equipped with Cummins ISB® engines, refer to Cummins QuickServe® Online, your Cummins Engine Operation Manual, or contact a certified Cummins repair location for specific engine maintenance intervals, capacities, and instructions.</b>		
	Engine Oil Level – Inspect	Refer to Engine Operation and Maintenance Manual.	
	Fan Belt – Inspect	Refer to Engine Operation and Maintenance Manual.	
	Air Filter – Check Restriction	Refer to Engine Operation and Maintenance Manual.	
	Air Induction System – Check looseness / leaks	Refer to Engine Operation and Maintenance Manual.	
	Air Filter – Replace	Refer to Engine Operation and Maintenance Manual.	
	Engine Oil and Filter(s) – Replace	Refer to Engine Operation and Maintenance Manual.	
	Valve Lash Adjustment (I-6 only)	Refer to Engine Operation and Maintenance Manual.	
	Fan Belt Auto Tensioner – Inspect	Refer to Engine Operation and Maintenance Manual.	
	Fuel Filter – Drain Sediment Bowl ( I-6 only)	Refer to Engine Operation and Maintenance Manual.	
	Fuel Filter – Drain Separated Water	Refer to Engine Operation and Maintenance Manual.	
	Fuel Filter – Replace	Refer to Engine Operation and Maintenance Manual.	
Fuel Tank	Fuel Tank – Drain Water	B	
	Fuel Sender, Hose Connections – Check for loose connectors		12 months
	Fuel Tank(s) – Drain and flush		12 months
Exhaust System	Pipes / Diesel Oxidation Catalyst / Diesel Particulate Filter / Muffler – Inspect for leakage / looseness	A, B	
	Diesel Particulate Filter (DPF) – Service	Refer to Engine Operation and Maintenance Manual.	
	Diesel Exhaust Fluid (DEF) Supply Module Filter — Replace	200,000 miles / 322,000 km or 6,500 hours	

Lubrication and Maintenance Interval: Bus — Recommended Synchronized Intervals (cont.)

System	Item	Intervals	Special Interval (3) : km (miles) / hours / months
Transmission	Automatic Trans Fluid – Check Level	A, B	
	Shift Selector / Linkage – Check Function	A, B	
	Neutral Start Switch – Check Function	A, B	
	Automatic Trans Fluid Filter(s) – Replace		<p>Allison 1000 PTS – Spin-On Control Main filter with any fluid, first 8,000(5,000) / – / _</p> <p>With mixed conventional and Synthetic Trans fluid for Main or Lube / Aux filter – every 80,000(50,000) / – / 24</p> <p>With Synthetic Trans fluid only for Main or Lube / Aux filter – every 80,000(50,000) / – / 24</p> <p>Allison 2000 – controls filter with any fluid type At first 8,000(5,000) / 200 / – and then every 80,000(50,000) / – / 24 thereafter</p> <p>Allison MD Main Filter with any fluid type At first 8,000(5,000) / 200 / – and then regular interval thereafter</p>

## Maintenance

### Lubrication and Maintenance Interval: Bus — Recommended Synchronized Intervals (cont.)

System	Item	Intervals	Special Interval (3) : km (miles) / hours / months
Transmission (Cont.)	Automatic Trans Fluid Filter(s) – Replace (Continued)		Allison MD Main Filter and Lube Filter with conventional or conventional / synthetic mixed fluid every 40,000(25,000) / 1,000 / 12  Allison Gold MD Main and Lube Filters with factory filled synthetic fluid every 241,000(150,000) / 4,000 / 48
	Conventional or Conventional / Synthetic Mixed Automatic Trans Fluid – Replace		Allison MD – 40,000(25,000) / 1,000 / 12 Allison 1000 PTS – 80,000(50,000) / — / 24 Allison 2000 – 80,000(50,000) / — / 24
	Factory-filled Synthetic Non-Mixed Automatic Trans Fluid – Replace		Allison 1000 PTS – 160,000(100,000) / – / 48 Allison 2000 – 160,000(100,000) / – / 48 Allison MD – 240,000(150,000) / 4,000 / 48 (Allison GOLD FILTERS required)
Rear Axle	<b>Stabile Ride</b> Suspension Fasteners / Components – Check	A, B	
	Axle Flange Nuts – Retorque	B	
	Ride Height - Check	B	
	Axle U-bolts – Retorque		At first 1,600 km (1,000 miles) then every 58,000 km (36,000 miles) thereafter



**Lubrication and Maintenance Interval: Bus — Recommended Synchronized Intervals (cont.)**

System	Item	Intervals	Special Interval (3) : km (miles) / hours / months
Rear Axle (Cont.)	Rear Axle With Petroleum Oil – Change		96,000(60,000) / – / 12
	Rear Axle Wheel Ends – Inspect for leaks, lube level / condition, and check end play with dial indicator.		160,000(100,000) / – / 12 Also at brake lining service  If wheel end play is found to be outside the 0.001 in. to 0.005 in. specification, or lube condition is contaminated or low, then perform a full wheel end tear down. Inspect bearings, spindle, and spindle nuts for excessive wear and replace as necessary.
	Rear Axle With Synthetic Oil – Change		Dana® Spicer®: 288,000(180,000) / – / 3 years  Meritor: 400,000(250,000) / - / 3 years
	Rear Axle Wheel Ends – Full tear down inspection of all wheel end components, regardless of condition of lube and wheel bearing endplay.		800,000 miles (500,000 km) / – / 5 Years
Tires / Wheels	Air Pressure – Check	A, B	
	Wear and Condition – Check	A, B	
	Wheel Stud Nuts – Retorque	A, B	
	Spin Balance		At time of tire mounting

## Maintenance

### Lubrication and Maintenance Interval: Bus — Recommended Synchronized Intervals (cont.)

System	Item	Intervals	Special Interval (3) : km (miles) / hours / months
Body / Components	Body – Check loose, damaged, missing parts	A, B	
	Chassis – Check for loose, damaged, missing, parts	A, B	
	Fluid Leaks – Check	A, B	
	Accelerator Pedal – Check Function	A, B	
	Entry Door – Check Operation	A, B	
	Emergency Doors / Exits and Buzzers – Check	A, B	
	Roof Hatch(es) – Check Operation	A, B	
	Lights Interior / Exterior – Check	A, B	
	Headlights, Bright / Dim / Daytime – Check	A, B	
	Seat Belt(s) Bolts – Check Operation / Condition	A, B	
	Warning lights, Stop Arm(s), Crossing Gate, Entrance door / Warning lights Interaction – Check	A, B	
	Safety Equipment As Equipped – Check	A, B	
	Optional Components As Equipped – Check	A, B	
	Post Trip Inspection Feature – Check	A, B	

**Lubrication and Maintenance Interval: Bus — Recommended Synchronized Intervals (cont.)**

System	Item	Intervals	Special Interval (3) : km (miles) / hours / months
Body / Components (Cont.)	Inspect and Clean Step Well and All Other Heater Cores and Blower Areas	A, B	<b>NOTE: For units without filter, more frequent cleaning may be required.</b>
	Step Well and All Heater Core Air Filters – Inspect / Clean or Replace	A, B	
	Air Conditioner (Optional) – Check Performance	B	
	All Seat Base Bolts	B	
	Body Mounting Bolts – Inspect Tightness		At 1,600 km (1,000 miles) then every 4,800 km (3,000 miles)
	Heater Hoses and Connections – Check Condition		12 months  <b>NOTE: See Heater and Coolant Hose Inspection and Replacement Guide in this section for additional information.</b>
	Undercoating Inspection		Inspect the undercoating of school buses annually and recoat as required.

## Unit Refill Capacities

### Air Conditioner Refrigerant

See air-conditioner manufacturer's Service / Operator Manual for aftermarket bus A/C system specifications.

**Table 15 Axle-Rear**

Axle	Axle Lube Capacities Liters (Pints)
Dana® Spicer® S11-130, S14-130, S16-130,	7.5 (16)
Dana® Spicer® 17060S, 19060S, 21060S, 23060SH	13.2 (28)
Meritor MS-17-14X-3DFL, MS-19-14X-3DFL, MS-21-14X-3DFL,	15.9 (33.6)
Meritor RS-23-160	18.7 (39.5)

### Cooling System Refill Capacities

Cooling system capacities vary greatly due to variations in bus length, number of heaters and engine model. Total capacity may range from 9 - 15 gallons.

- For vehicles equipped with Navistar's engines, fill with a 50/50 mixture of Nitrite-free Shell Rotella® Ultra Extended Life Coolant (ELC) (yellow) concentrate and demineralized or distilled water, or Nitrite-free Shell Rotella® Ultra ELC 50/50 Premix (yellow).
- For vehicles equipped with Cummins® ISB engines, fill with a 50/50 mixture of Shell Rotella® Extended Life Coolant (ELC) (red) concentrate and demineralized or distilled water, or Shell Rotella® ELC 50/50 Premix (red).

If the system has been flushed with water or cleaner, a significant amount of the rinse water will remain in the system. In this case refilling with a mixture with a higher percentage (60 to 66%) of coolant concentrate is advised in order to achieve a final mixture closer to 50/50. Fill the system and run the vehicle until the thermostat opens. Before adding any fluid, check the coolant concentration and add additional water or concentrated undiluted coolant to adjust the concentration. Run the vehicle and retest for coolant volume level (set to "MAX" line) and concentration level.

### Diesel Exhaust Fluid Tank

Diesel Exhaust Fluid (DEF) tank refill capacity varies depending on the vehicle models. Its total capacity may range from 7 to 23 gallons (26 - 87 Liters). The Tank is typically located on the right side of the bus behind an access door.

**Engine Crankcase**

For specific engine crankcase capacities refer to separate Engine Operation and Maintenance Manual provided with vehicle.

**NOTE: For vehicles equipped with Cummins® ISB engines, refer to Cummins QuickServe® Online, your Cummins Engine Operation Manual, or contact a certified Cummins repair location for specific engine maintenance intervals, capacities, and instructions.**

**Full Power Brakes – Brake Fluid**

Approximately 6 Liters (1.6 Gallons).

**Power Steering System**

**Table 16 Power Steering Systems**

Steering Gear	Power Steering Fluid Volume (pints / liters)
M-100	8.4/3.9*
TAS40	7.4/3.5*
TAS66	8.4/3.9*
THP45	7.4/3.5*
THP60	8.4/3.9*
* Approximate refill quantity, refer to power steering reservoir for proper fill marks.	

**Transmission**

**Table 17 Transmission**

Transmission Model	Transmission Fluid Volumes Liters (Pints)
Allison Automatic – 1000 PTS 5 Speed	18 (38)*
Allison Automatic – B-300 5 Speed	14 (29)*
Allison 5 Speed Automatic –1000_PTS	18 (38)*
Allison 5 Speed Automatic – 2100 PTS	18 (38)*
Allison 5 Speed Automatic – 2200 PTS	18 (38)*
Allison 5 Speed Automatic – 2500 PTS	18 (38)*
Allison 5 Speed Automatic – 2550 PTS	18 (38)*
Allison 5 Speed Automatic, School and Shuttle Bus – 3000 PTS	27 (58)*
* Approximate refill quantity (less than initial fill since a portion of the used fluid remains in external circuits and transmission cavities). Check at operating temperature and top off as required.	

**Tire and Rim Combinations**

**Table 18 Approved Tire and Wheel Combinations**

<b>Tire Size</b>	<b>Rim Width</b>
9R22.5	6.75, 7.50
10R22.5	6.75, 7.50
11R22.5	7.50, 8.25
12R22.5	8.25, 9.00
225/70R19.5	6.75
235/80R22.5	6.75, 7.50

**Table 18 Approved Tire and Wheel Combinations (cont.)**

<b>Tire Size</b>	<b>Rim Width</b>
245/70R19.5	6.75, 7.50
255/70R22.5	6.75, 7.50, 8.25
265/70R19.5	6.75, 7.50, 8.25
275/80R22.5	7.50, 8.25
295/75R22.5	8.25, 9.00
315/80R22.5	9.00

Lubricant and Sealer Specifications

Lubricant and Sealer Specifications

Component	Component Vendor / Lubrication Type	Viscosity / Ambient Temperature / Notes
<b>Non-driving Front Axle</b>		
Front axle wheel bearing oil	Eaton® / Dana® axle (Generic)	75W : -40°C to -26°C (-40°F to - 15°F) 75W-80: -40°C to 27°C (-40°F to 80°F) 75W-90: -40°C to 38°C (-40°F to 100°F) 75W-140: -40°C and above (-40°F and above) 80W-90: -26°C to 38°C (-15°F to 100°F) 80W-140: -26°C and above (-15°F and above) 85W-140: -12°C and above (10°F and above)
	Eaton® / Dana® axle: multipurpose EP gear lube of API GL-5 quality meeting MIL-PRF-2105E specs including *synthetic lubricants.  <b>*: Do Not Mix conventional lube with Synthetic lube.</b>	75W : -40°C to 0°C (-40°F to 32°F) 75W-90: -40°C to 38°C (-40°F to 100°F) 75W-140: -40°F and above (-40°C and above) 80W : -26°C to 21°C (-15°F to 70°F) 80W-140: -26°C and above (-15°F and above) 90W : -12°C to 38°C (10°F to 100°F) 85W-40: -12°C and above (10°F and above) 140W : 4°C and above (40°F and above)

## Maintenance

### Lubricant and Sealer Specifications (cont.)

Component	Component Vendor / Lubrication Type	Viscosity / Ambient Temperature / Notes
Front axle wheel bearing oil – (Cont)	Meritor: Synthetic from factory with Cognis Emgard® 75W-90 will have a tag attached to fill plug that reads as follows: <b>Filled with synthetic lube. Do Not Mix.</b>	75W-90
	Meritor: Petroleum 0-76-A Hypoid Gear Oil 0-76-D Hypoid Gear Oil 0-76-E Hypoid Gear Oil 0-76-J Hypoid Gear Oil Petroleum oil: engine oil API-CF2	85W-140: -12°C and above (10°F and above) 80W-90: -26°C and above (-15°F and above) 75W-90: -40°C and above (-40°F and above) 75W : -40°C to 2°C (-40°F to 36°F)  SAE 40 or 50: -12°C and above (10°F and above) SAE 30: -26°C and above (-15°F and above)
Front axle wheel bearing grease, Tie Rod Ends, Drag Link, Kingpin and Bushing	Eaton® / Dana® axle, Meritor axle: Fleetrite® NLGI#2 Lithium Complex Based Moly grease P/N 991044C2 or equivalent GC / LB NLGI #2 Multi-purpose Lithium Complex grease	<b>NOTE: Eaton® / Dana® and Meritor Easy Steer axles: With chassis load on axle, force grease through thrust bearings; then with axle lifted clear of floor, force grease between kingpin and bushing surfaces.</b>
<b>Brakes</b>		
Brake Fluid	DOT 3 Brake fluid	



Lubricant and Sealer Specifications (cont.)

Component	Component Vendor / Lubrication Type	Viscosity / Ambient Temperature / Notes
<b>Engine</b>		
Engine Lubricating Oil	API Classification CI-4 or later 15W -40: -12°C and above (10°F and above) Below -12°C (10°F) See Engine Operation and Maintenance Manual	
Engine Lubricating Oil- Cummins ISB® Engines only	<b>NOTE: For vehicles equipped with Cummins ISB® engines, refer to Cummins QuickServe® Online, your Cummins Engine Operation Manual, or contact a certified Cummins repair location for specific engine maintenance intervals, capacities, and instructions.</b>	
<b>Electrical</b>		
Terminals-Lubricant Sealing Grease	Fleetrite® 472141-C1	
Connectors - Dielectric Grease	NYOGEL® 760 G	
<b>Steering</b>		
Power Steering fluid change	Fleetrite® P/N CH990625C2	
Strg. Gear Ross TAS- Output Seal - Lubricate	Fleetrite® Lithium Complex Based Moly grease P/N 991044C2 or equivalent GC / LB NLGI #2 Multi-purpose Lithium Complex grease	
Strg. Intermediate Shaft U-Joints / Slip Joint - Lubricate	Fleetrite® NLGI #2 Lithium Complex Based Moly grease P/N 991044C2 or equivalent GC / LB NLGI #2 Multi-purpose Lithium Complex grease	

## Maintenance

### Lubricant and Sealer Specifications (cont.)

Component	Component Vendor / Lubrication Type	Viscosity / Ambient Temperature / Notes
<b>Drive Shaft</b>		
U-Joint - Lubricate	Fleetrite® NLGI #2 Lithium Complex Based Moly grease P/N 991044C2 or equivalent GC / LB NLGI #2 Multi-purpose Lithium Complex grease	
<b>Clutch</b>		
Release Bearing / Shafts / Fork - Lubricate	Fleetrite® NLGI #2 Lithium Complex Based Moly grease P/N 991044C2 or equivalent GC / LB NLGI #2 Multi-purpose Lithium Complex grease	
<b>Cooling System</b>		
Coolant		Refer To Engine Manual
Extended Life Coolant	Shell Rotella® Extended Life Coolant (ELC)	50:50 mix equals -37°C (-34°F) freeze protection 53:47 mix equals -40°C (-40°F) freeze protection 60:40 mix equals -51°C (-60°F) freeze protection

**Lubricant and Sealer Specifications (cont.)**

Component	Component Vendor / Lubrication Type	Viscosity / Ambient Temperature / Notes
<b>Transmission</b>		
Eaton® / Dana® (Non-Synchronized) - Fill / Change  (Lubricants are listed in order of preference)	Mineral Gear Oil API-GL-1 (Rust and Oxidation Inhibited) Fleetrite® P/N 991061C1  Petroleum Oil: Engine Oil API-CJ, or CI	SAE 90: Above -18°C (0°F) SAE 80: Below -18°C (0°F) SAE 50: Above -18°C (0°F) SAE 40: Below -18°C (0°F)
* EP Gear Oils are not recommended for use in manual transmissions.		
	Synthetic Oil: Synthetic SAE 50 Manual Transmission Oil Meeting API MT-1 Fleetrite® P/N 991884C1	SAE 50: All Temperatures
Eaton® Fuller® UltraShift®	WetClutch (Synthetic): Castrol® TranSynd® or TES-295  Gear Box: EmGard® 2979	All Temperatures  SAE 50: All Temperatures
Eaton® / Dana® (Synchronized) - Fill / Change  (Lubricants are listed in order of preference)	Mineral Gear Oil API-GL-1 (Rust and Oxidation Inhibited) Fleetrite® P/N 991061C1  Petroleum Oil: Engine Oil API-CJ, or CI	SAE 90: Above -12°C (10°F) SAE 80: Below -12°C (10°F) SAE 50: Above -12°C (10°F) SAE 40: Below -12°C (10°F)
Eaton® / Dana® (Synchronized) - Fill / Change – (Cont)	Synthetic Oil: Synthetic SAE 50 Manual Transmission Oil Meeting API MT-1 Fleetrite® P/N 991884C1	SAE 50: All Temperatures
	Synthetic Oil: API MT-1*	SAE 50: All Temperatures
* Do not use multi-weight and GL-5 EP gear oils because they may cause transmission failure or damage.		

## Maintenance

### Lubricant and Sealer Specifications (cont.)

Component	Component Vendor / Lubrication Type	Viscosity / Ambient Temperature / Notes
Allison - Synthetic Automatic Transmission Fluid (ATF) Fill / Change (optimal - recommended)	Fleetrite® Synthetic ATF (P/N: FATF27101Q), or Allison / Castrol® TRANSYND® synthetic ATF, or fluids meeting AllisonTES 295 specification. Approved Synthetic ATF Supplier Web site: <a href="http://www.allisontransmission.com/service/">http://www.allisontransmission.com/service/</a>	All Temperatures. Recommended for highest transmission durability and lowest maintenance costs.
Allison - Conventional Automatic Transmission Fluid (ATF) Fill / Change	Meets the requirements for Allison TES 389 specification. Approved Conventional ATF Supplier Web site: <a href="http://www.allisontransmission.com/service/">http://www.allisontransmission.com/service/</a>	Below -25°C (-13°F) pre-heat is required
<b>Rear Axle</b>		
Single speed	Gear oil meeting MIL-PRF-2105E, API MT-1, GL-5	75W : -40°C to -26°C (-40°F to - 15°F) 75W-80: -40°C to 27°C (-40°F to 80°F) 75W-90: -40°C to 38°C (-40°F to 100°F) 75W-140: -40°C and above (-40°F and above) 80W-90: -26°C to 38°C (-15°F to 100°F) 80W-140: -26°C and above (-15°F and above) 85W-140: -12°C and above (10°F and above)

Lubricant and Sealer Specifications (cont.)

Component	Component Vendor / Lubrication Type	Viscosity / Ambient Temperature / Notes
Single speed – Continued.	International axle: multipurpose EP gear lube of API GL-5 quality meeting MIL-PRF-2105E or SAE J2360 specs including synthetic lubricants.	75W : -40°C to 0°C (-40°F to 32°F) 75W-90: -40°C to 38°C (-40°F to 100°F) 75W-140: -40°C and above (-40°F and above) 80W : -26°C to 21°C (-15°F to 70°F) 80W-140: -26°C and above (-15°F and above) 90W : -12°C to 38°C (10°F to 100°F) 85W-140: -12°C and above (10°F and above) 140W : 4°C and above (40°F and above)
	Meritor: Synthetic from factory with Cognis Emgard® 75W-90 will have a tag attached to fill plug that reads as follows: <b>Filled with synthetic lube. Do Not Mix.</b>	
	Meritor petroleum: 0-76-A Hypoid Gear Oil 0-76-B Hypoid Gear Oil 0-76-D Hypoid Gear Oil 0-76-E Hypoid Gear Oil 0-76-L Hypoid Gear Oil	GL-5, SAE 85W-140: Above -12°C (10°F) GL-5, SAE 85W-140: Above -26°C (-15°F) GL-5, SAE 80W-90: Above -26°C (-15°F) GL-5, SAE 75W Max outside temp. 2°C (35°F): Above -40°C (-40°F) GL-5, SAE 75W-140: Above -40°C (-40°F)

## Maintenance

---

### Torque Specification Charts

#### Disc Wheels Torque Chart

Stud Size	Nut Size	Specified Torque	
		N-m	Lb-Ft
22 mm	Flange Nut – 33 mm Across Flats	610-678	450-500
<b>NOTE: Do not use lubrication on dry threads. Where excessive corrosion exists, a light coat of lubricant on first three threads of stud bolt is permitted. Keep lubricant away from:</b>			
<ul style="list-style-type: none"><li>• Hex nut</li><li>• Flange nut washer surface and flat on disc wheel.</li></ul>			

#### Steering Column Pinch Bolts Torque Chart

Bolt Type	Specified Torque	
	N-m	Lb-Ft
7/16-20	95-102	70-75

**Axle U-Bolt Nut Torque Chart**

Feature Code	Rear Suspension Capacity and Type	Torque	
		N • m	lbf - ft
14SBK	19,800-lb Capacity, 2 Stage Vari-Rate	353-407	260-300
14SBW	21,000-lb Capacity, V-Rate, with 4,500-lb Auxiliary Spring	353-407	260-300
14TBG	12,000-lb Capacity, International Air Suspension (IROS) for axles 14ADN, 14ADP,14AJC,14AJE, 14ATP, and 14ATR.	353-407	260-300
	12,000-lb Capacity, International Air Suspension (IROS) for all other axles.	502-542	370-400
14TBH	15,500-lb Capacity, International Air Suspension (IROS) for axles 14ADN, 14ADP,14AJC,14AJE, 14ATP, and 14ATR.	353-407	260-300
	15,500-lb Capacity, International Air Suspension (IROS) for all other axles.	502-542	370-400
14TBT	23,000-lb Capacity, International Air Suspension (IROS) for axles 14ADN, 14ADP,14AJC,14AJE, 14ATP, and 14ATR.	353-407	260-300
	23,000-lb Capacity, International Air Suspension (IROS) for all other axles.	353-407	260-300
14VAB	13,500-lb Capacity, RR, Springs, Vari-Rate, with 4,500-lb Auxiliary Rubber Spring	353-407	260-300
14VAC	15,500-lb Capacity, RR, Springs, Vari-Rate, with 4,500-lb Auxiliary Rubber Spring	353-407	260-300
14VAD	18,500-lb Capacity, RR, Springs, Vari-Rate, with 4,500-lb Auxiliary Rubber Spring	353-407	260-300
14VAM	10,000-lb Capacity, RR, Steel Springs	353-407	260-300
14VAN	9,000-lb Capacity, RR, Steel Springs	353-407	260-300

**NOTE: For all other vendor supplied suspensions, refer to vendor's Web site for proper torque specifications.**

## Maintenance

---

Feature Code	Front Suspension Capacity and Type	Torque	
		lbf - ft	N • m
3ADA	8,000-lb Capacity, Parabolic Taper Leaf	353-407	260-300
3ADB	10,000-lb Capacity, Parabolic Taper Leaf	353-407	260-300
3AGZ	7,000-lb Capacity, Parabolic Taper Leaf	353-407	260-300

### Wiper Arm Torque Chart

	Specified Torque	
	N-m	Lb-Ft
Wiper Pivot M20 Hex Nut	28	21

### Seat Base Bolts

	Specified Torque	
	N-m	Lb-Ft
All Seat Base Bolts	21.7 to 27	16 to 20

### Filter List

Filter part numbers and / or specifications may change during the life-cycle of this vehicle. Current information on the appropriate chassis and engine filters for your vehicle can be obtained by contacting your local International dealer parts department. If you need assistance finding a local International dealer, use the Dealer Locator icon at [www.icbus.com](http://www.icbus.com).



---

## SECTION 13 — CUSTOMER ASSISTANCE

### Service Information

The continued premium performance of this IC Bus vehicle can best be ensured through proper servicing. This can be accomplished in several ways.

**IC Bus Dealers** ... Your local IC Bus dealer provides an excellent resource – through his knowledgeable, experienced, and well equipped service staff – to handle all your maintenance, repair, and replacement work.

**Service Publications** ... Those persons who are properly trained technicians with the facilities, equipment, tools, safety instructions and know-how to properly and safely service a bus can purchase the appropriate service manual sections applicable to specific vehicle components or areas of this vehicle. Engine diagnostic manuals and engine service manuals for all current MaxxForce® diesel engines are also available to these trained persons for purchase. Information on the purchase of available service publications for this vehicle can be found on the [www.icbus.com](http://www.icbus.com) or [www.internationaltrucks.com](http://www.internationaltrucks.com) Web site, or by contacting your local IC Bus or International Truck Dealer.

These resources are also available via the internet, by an annual subscription to the **International® Service Portal<sup>SM</sup> Web site**, or via the **OnCommand™ Service Information DVD**. Information on the Service Portal<sup>SM</sup>. Web site's content, availability, and fee structure can be obtained by contacting

your local International Truck dealer or, in the case of a National Account, an International Fleet Service Manager.

The OnCommand™ Service Information DVD contains Navistar branded truck, engine, and bus information including service and diagnostic manuals, technical letters / service bulletins, diagnostic trouble code indices, troubleshooting guides, circuit diagram manuals, new vehicle processing manual, and a help screen.

**NOTE: When ordering any service information, be sure to provide your vehicle's model designation, build date, engine series, and the Vehicle Identification Number (VIN).**

### Navistar, Inc., Warranty Program

**Standard Warranty • Optional Service Contracts • Custom Service Contracts • Performance PM®**

The Navistar Warranty Program provides IC Bus customers with a better choice when it comes to Standard Warranty and Service Contract Coverage. The **Standard Warranty** is the first tier of the Navistar. Warranty Program. It provides the foundation for all extended coverages.

Vehicle Coverage, Towing, Engine and Engine Electronics, Major Component, and Pre-Packaged System Component protection can be obtained under the Navistar. Warranty Program through **Optional Service Contracts**.

## Customer Assistance

---

**Custom Service Contracts**, the most flexible aspect of the NavistarWarranty Program, can provide extended protection that is specifically tailored to meet each customer's specific requirements.

Finally, through **Performance PM®**, customers can obtain a comprehensive preventative maintenance program designed to ensure consistency in pricing and the level of service received.

### **ADVANTAGES of Navistar, Inc. Warranties**

- Extends warranty protection to specified length and component coverage to suit individual needs
  - Honored at all IC Bus dealer locations in North America
  - Stabilized and predictable maintenance costs
  - Increased owner confidence and peace of mind
  - Improved resale value on your vehicle – International Truck Warranties may be transferable for a nominal fee. Contact the Service Contract Center 1-800-336-4500 option 5 for transferability
  - Most coverage is 100% parts and labor with **NO DEDUCTIBLES**
  - Customized warranty programs are offered to suit your needs - your specification - your vocation
  - Optional Service Contracts, Custom Service Contracts, and Performance PM, designed to ensure the lowest possible cost of ownership, are also available
- Published Service Contracts Performance PM® Service, designed to ensure the lowest possible cost of ownership, are also available.
  - Optional Service Contracts have been pre-packaged to fit most common applications.

### **HOW TO OBTAIN Navistar, Inc. Warranties**

- **Standard Warranty:** Your new IC Bus vehicle is automatically registered in the Navistar Warranty System at the time of delivery. No further action, on your part, is required.
- **Optional Service Contracts, Custom Service Contracts, or Performance PM®:** These programs are sold exclusively through your IC Bus dealer. You have 365 days and up to a maximum of 160,000 km (100,000 miles), from DTU (delivery to end user), to purchase an extended warranty on your vehicle. The vehicle must also have coverage remaining under the Standard Warranty. For extended warranty purchases between, 181 through 365 days from DTU and <160,000 km (100,000 miles) an additional fee will be assessed. If you would like the predictable cost of ownership and peace of mind provided by the NavistarWarranty Program, please contact your IC Bus dealer today!

**SECTION 14 — INDEX**

**Numerics/Symbols**

39 Inch Flex Seat.....104

**A**

ABS / Plastic.....182

ABS Connections and Sensors.....197, 199

ABS Self-Check.....156

Accessory Feed Connections.....200

Activation.....79

Additional Components Covered.....6

Additional Unsafe Practices.....131

Adjustable Tilt Steering Column.....61

Adjusting the Length of the Tether.....100

After the Engine Starts.....129

Air Brake Gauge.....153

Air Brakes.....151, 195

    ABS Connections and Sensors.....197

    Air Disc Brakes (0004JBZ, 0004JCC, 0004WEY,  
    0004WEZ).....151

    Air Dryer.....196

    Air Dryer Desiccant Replacement.....196

    Air Dryer Heater.....197

    Air Dryer Purge Valve.....197

    Air Reservoir / Tanks Moisture Draining.....197

    Brake Inspection and Adjustment.....195

    Parking Brake Indicator Light.....153

    Using Air Brakes.....152

    Using the Air Parking Brake.....152

        Air Brake Gauge.....153

        To engage Air Parking Brake.....152

**A (CONT.)**

*Air Brakes (cont.)*

    To release Air Parking Brake.....152

Air Cleaner Element Service.....202

Air Conditioner Refrigerant.....238

    Axle-Rear Table.....238

Air Conditioning.....123

Air Disc Brakes (0004JBZ, 0004JCC, 0004WEY,  
    0004WEZ).....151

Air Dryer.....196

Air Dryer Desiccant Replacement.....196

Air Dryer Heater.....197

Air Dryer Purge Valve.....197

Air Induction System.....202

Air Reservoir / Tanks Moisture Draining.....197

Air Restriction Gauge Service.....203

    High Restriction Reading Table.....204

    No Restriction Reading Table.....204

    Troubleshooting.....204

Air-Actuated Door.....83

Air-Operated Passenger Door Adjustments.....191

    Door Opening and Closing Speed Adjustment Points.....191

        Closing Speed Adjustment.....191

        Opening Speed Adjustment.....191

        Pressure Regulator Adjustment.....191

    Electrically Actuated Entrance Door Adjustment.....192

Allison Generation IV Push-Button Shift Selector.....161

Allison Generation IV T-Bar Gearshift Control.....160

Allison Transmission Mechanical Lever Shifters.....159

Alternator–Starter–Battery Test.....199

## A (CONT.)

Anti-Freeze.....	210
Antilock Braking System (ABS).....	155
Antilock Driving Tips.....	156
Approved Tire and Wheel Combinations Table.....	240
Assistance Guide.....	2
Audible Alarms Table.....	57
Audible Warning Buzzer.....	87
Automatic Headlights.....	76
Automatic Transmission Operating Temperatures.....	163
Automatic Transmission Operation.....	158
Allison Generation IV Push-Button Shift Selector.....	161
Allison Generation IV T-Bar Gearshift Control.....	160
Allison Transmission Mechanical Lever Shifters.....	159
Automatic Transmission Operating Temperatures.....	163
Backup Alarms.....	163
Economy Mode.....	163
Parking the Bus With Transmission Shift / Wheelchair Lift	
Interlocks.....	162
Wheelchair Lift Extension Operation.....	162
Parking the Vehicle.....	161
Retracting and Stowing Operation.....	162
Standard Allison 1000 PTS Transmission.....	158
Starting Bus in Motion.....	162
Starting Bus in Motion With Transmission Shift / Wheelchair	
Lift Interlocks.....	162
Automatic Transmission Starter Interlock.....	128
Auxiliary Fuel-Fired Heater System.....	24
Auxiliary Fuel-Fired Heater System Table.....	24
Auxiliary Fuel-Fired Heater System (Optional).....	120
Description.....	121
Heater Control Switch.....	121

## A (CONT.)

### *Auxiliary Fuel-Fired Heater System (Optional) (cont.)*

Heating Mode.....	122
Introduction.....	120
Operation.....	121
Switching-Off Sequence.....	123
Auxiliary Fuel-Fired Heater System Table.....	24
Auxiliary Heaters.....	120
Axle U-Bolt Nut Torque Chart.....	249
Axle-Rear Table.....	238
Axles.....	192
Body.....	193
Front Axle – Alignment.....	193
Front Axle – Inspection and Lubrication.....	192
Front Axle – Normal Maintenance.....	192
Rear Axle – Inspection and Lubrication.....	193

## B

Backup Alarms.....	163
BE / CE Bus Front View.....	10
BE / CE Bus Rear View.....	11
BE Bus Left View.....	13
BE Bus Right View.....	12
Body.....	193
Body Fluid Cleanup Kit.....	167
Body Fuse / Circuit Breaker Panel.....	170
Fuse Description Chart Table.....	171
Brake Fluid Level.....	198
Brake Inspection and Adjustment.....	195, 197
Brake Lines, Hoses, and Fittings.....	198
Brakes.....	18, 194
ABS Self-Check.....	156

**B (CONT.)**

*Brakes (cont.)*

Air Brakes.....	151, 195
ABS Connections and Sensors.....	197
Air Disc Brakes (0004JBZ, 0004JCC, 0004WEY, 0004WEZ).....	151
Air Dryer.....	196
Air Dryer Desiccant Replacement.....	196
Air Dryer Heater.....	197
Air Dryer Purge Valve.....	197
Air Reservoir / Tanks Moisture Draining.....	197
Brake Inspection and Adjustment.....	195
Parking Brake Indicator Light.....	153
Using Air Brakes.....	152
Using the Air Parking Brake.....	152
Antilock Braking System (ABS).....	155
Antilock Driving Tips.....	156
Brakes Table.....	18
Chassis Inspection.....	199
Downhill Operation.....	147
General Information.....	194
Hydraulic Brakes.....	147
Power Parking Brake System.....	149
Split-System Feature.....	148
Using the Full Power Brake System.....	147
Warning Indicators.....	148
Hydraulic Full Power Brakes.....	197
ABS Connections and Sensors.....	199
Brake Fluid Level.....	198
Brake Inspection and Adjustment.....	197
Brake Lines, Hoses, and Fittings.....	198
Fluid Precautions.....	198
Hydraulic Brake Fluid Accumulators.....	199

**B (CONT.)**

*Brakes (cont.)*

Parking Brake / Wheelchair Lift Interlock and Alarm.....	154
Parking Brake / Wheelchair Lift (Optional) Alarm.....	154
Parking Brake / Wheelchair Lift Interlock–Retracting and Stowing Operation.....	154
Wheelchair Lift Extension Operation.....	154
Pedal Adjustment.....	157
Brakes Table.....	18
Buckling Up.....	102
BUS-SCAN® 100 System.....	89
Unloading Students With Engine Off.....	89

**C**

Canadian Registered Vehicles.....	5
Care of Seat Belts.....	100
Inspection of Seat Belts.....	101
Cautions / Warnings / Notes.....	1
CE Bus Left View.....	15
CE Bus Right View.....	14
CE White Integrated Child Restraint Seats (Optional).....	107, 109
Certified Clean Idle.....	130
Chassis Fuse / Circuit Breaker Chart.....	168
Fuse Description Chart Table.....	169
Chassis Inspection.....	199
Chassis Lubrication.....	187
Chassis-Mounted Charge Air Cooler and Radiator Core Inspection and Cleaning.....	205
Checking Inflation.....	219
Child Restraint Anchorage Systems (Optional).....	109
Location and Use of Lower LATCH Anchors.....	110
Circulation Fans.....	124
Cleaning.....	217

## C (CONT.)

Closing Speed Adjustment.....	191
Cold Weather Operation.....	145
Engine Idling.....	146
Instructions.....	145
Winter Fronts.....	146
Compass Declination Zone Set Procedure.....	51
Compass Directional Calibration Procedure.....	54
Component Code Numbers.....	2
Coolant and Optional Coolant Filter.....	209
Coolant Concentration / Freeze Point.....	209
Cooling System.....	205
Cooling System Refill Capacities.....	238
Crossing Arm Cleaning.....	184
Crossing Gate.....	86
Cruise Control.....	71
Operation.....	71
Cushion Release Latch.....	112

## D

Deactivation.....	79
DEF Contamination or SCR System Fault.....	137
DEF Tank.....	134
DEF Tank Filling.....	216
Defrost Operating Instructions.....	120
Description.....	121
Diesel Exhaust Fluid.....	133
Diesel Exhaust Fluid (DEF) Storage.....	4
Diesel Exhaust Fluid Tank.....	238
Diesel Particulate Filter (DPF) Regeneration Table Table.....	142
Direct Drive Warning Indicators.....	34
Disc Wheels Torque Chart.....	248

## D (CONT.)

Door Opening / Closing.....	81
Opening / Closing.....	81
Three-Position Door Switch.....	82
Two-Position Door Switch.....	82
Door Opening and Closing Speed Adjustment Points.....	191
Closing Speed Adjustment.....	191
Opening Speed Adjustment.....	191
Pressure Regulator Adjustment.....	191
Downhill Operation.....	147
Drive Shaft.....	213
Driver Heater.....	119
Driver Seat Adjustment.....	95
Seat Height Adjustment.....	96
Driver Seat Belts.....	98
Driver Visual Warning Lights and Indicators.....	87
Driver's Adjustable Lap and Shoulder (Three-Point) Belt.....	98
Dual Tires Matching.....	221
Dual Tires Mixing.....	221

## E

Economy Mode.....	163
Eight-Lamp Amber and RED Warning Lights.....	84
Electric-Actuated Door.....	83
Electrical.....	199
Accessory Feed Connections.....	200
Alternator–Starter–Battery Test.....	199
Terminal Inspection–Cleaning–Corrosion Protection.....	199
Electrically Actuated Entrance Door Adjustment.....	192
Electronic Safety Messages.....	84
Emergency Door.....	91
Emergency Equipment (Recommended On-Board).....	166

*E (CONT.)*

*Emergency Equipment (Recommended On-Board) (cont.)*

- Body Fluid Cleanup Kit.....167
- Fire Extinguisher.....166
- First Aid Kit.....166
- Reflective Triangle.....167
- Emergency Exit Windows.....92
  - Horizontal Emergency Exit Window.....92
  - Vertical Emergency Exit Window.....92
- Emergency Exits.....91
  - Emergency Door.....91
  - Emergency Exit Windows.....92
    - Horizontal Emergency Exit Window.....92
    - Vertical Emergency Exit Window.....92
  - Roof Vent / Hatch.....93
- Emergency Exits and Equipment.....24
  - Emergency Exits and Equipment Table.....24
- Emergency Exits and Equipment Table.....24
- Emergency Starting Using Jumper Cables.....177
- Emission Control Systems.....5
  - HD-OBD Foreword.....5
  - Supplemental Federal Emission Control System Warranty...5
- Engine.....200
  - Air Cleaner Element Service.....202
  - Air Induction System.....202
  - Air Restriction Gauge Service.....203
  - Chassis-Mounted Charge Air Cooler and Radiator Core
    - Inspection and Cleaning.....205
  - Cooling System.....205
  - Drive Shaft.....213
  - Engine Fluids and Contaminated Material.....201
  - Frame and Optional Tow Hooks.....211

*E (CONT.)*

*Engine (cont.)*

- Fuel System.....211
  - Fuel Tank Draining and Cleaning.....211
- General.....200
- Gravity-Fill Coolant Method.....205
  - Anti-Freeze.....210
  - Coolant and Optional Coolant Filter.....209
  - Coolant Concentration / Freeze Point.....209
  - Fan Clutch.....210
- Heater and Coolant Hose Inspection and Replacement
  - Guide.....210
- Heater System.....212
- Integrated Air Conditioning (IC Air) System.....212
- Scheduled Maintenance.....201
- Suspension (Air and Steel Springs).....213
- Engine and Exhaust Brake Systems Operation.....132
- Engine Brake, Exhaust Brake, or Retarder (Optional).....132
  - Engine and Exhaust Brake Systems Operation.....132
  - Operational Modes.....133
- Engine Compartment Fluid Check Points.....188
- Engine Crankcase.....239
- Engine Features.....129
  - Certified Clean Idle.....130
  - HD-OBD Overview.....130
  - Self Diagnostics.....130
- Engine Fluids and Contaminated Material.....201
- Engine Idling.....146
- Exhaust Aftertreatment.....133
  - Exhaust Diesel Particulate Filter Regeneration.....141
    - Parked Regeneration Procedure.....144
    - Regeneration Inhibit Switch.....144

## E (CONT.)

<i>Exhaust Aftertreatment (cont.)</i>	
Three-Position Regeneration Inhibit Switch.....	145
Two-Position Regeneration Inhibit Switch.....	145
Selective Catalytic Reduction System (If Equipped).....	133
DEF Contamination or SCR System Fault.....	137
DEF Tank.....	134
Diesel Exhaust Fluid.....	133
Introduction.....	133
Low DEF Level.....	134
Exhaust Diesel Particulate Filter (DPF).....	217
Cleaning.....	217
Regeneration.....	217
Transmission.....	217
Transmission Fluid Level.....	217
Exhaust Diesel Particulate Filter Regeneration.....	141
Diesel Particulate Filter (DPF) Regeneration Table	
Table.....	142
Parked Regeneration Procedure.....	144
Regeneration Inhibit Switch.....	144
Three-Position Regeneration Inhibit Switch.....	145
Two-Position Regeneration Inhibit Switch.....	145
Exterior.....	183
Crossing Arm Cleaning.....	184
Waxing or Polishing Vehicles.....	184
Exterior Checks.....	16
Exterior Checks Table.....	16
Exterior Checks Table.....	16
Exterior Lamp Check.....	78
Activation.....	79
Deactivation.....	79
Function.....	78
Switch Location.....	78

## F

Fan Clutch.....	210
Filter List.....	250
Fire Extinguisher.....	166
First Aid Kit.....	166
Flashing Stop Arm.....	86
Flooring.....	183
Fluid Precautions.....	198
Frame and Optional Tow Hooks.....	211
Front / Rear Suspension Table.....	18
Front Axle – Alignment.....	193
Front Axle – Inspection and Lubrication.....	192
Front Axle – Normal Maintenance.....	192
Front Suspension.....	18
Front / Rear Suspension Table.....	18
Fuel.....	130
Additional Unsafe Practices.....	131
Engine Brake, Exhaust Brake, or Retarder (Optional).....	132
Engine and Exhaust Brake Systems Operation.....	132
Operational Modes.....	133
Fuel and Lubricant Additives.....	131
Fueling Precautions.....	132
Fueling Procedures.....	131
Hazards of Diesel Fuel / Gasoline Blends.....	130
Reserve Fuel.....	132
Restarting After Running Out of Fuel.....	132
Ultra-Low Sulfur Diesel Fuel Requirements.....	130
Unacceptable Fuel Blends.....	130
Fuel and Lubricant Additives.....	131
Fuel System.....	211
Fuel Tank Draining and Cleaning.....	211



**F (CONT.)**

Fuel Tank Draining and Cleaning.....211  
 Fueling Precautions.....132  
 Fueling Procedures.....131  
 Full Power Brakes – Brake Fluid.....239  
 Function.....78  
 Fuse / Circuit Breaker Charts.....168  
     Body Fuse / Circuit Breaker Panel.....170  
     Chassis Fuse / Circuit Breaker Chart.....168  
 Emergency Starting Using Jumper Cables.....177  
 Tilt Hood.....176  
     Lowering the Hood.....177  
     Raising the Hood.....176  
 Typical Interior Fuse Panel Layout.....172  
     Fuse Panel Layout, Sheet 1.....172  
     Fuse Panel Layout, Sheet 2.....173  
     Fuse Panel Layout, Sheet 3.....174  
     Fuse Panel Layout, Sheet 4.....175  
 Fuse Description Chart Table.....169, 171  
 Fuse Panel Layout, Sheet 1.....172  
 Fuse Panel Layout, Sheet 2.....173  
 Fuse Panel Layout, Sheet 3.....174  
 Fuse Panel Layout, Sheet 4.....175

**G**

General.....200, 213  
 General Cleaning, All Surface Types.....181  
 General Information.....194  
 GHG Emission Control System Warranty Period.....6  
 Glass.....182  
 Gravity-Fill Coolant Method.....205  
     Anti-Freeze.....210  
     Coolant and Optional Coolant Filter.....209

**G (CONT.)**

*Gravity-Fill Coolant Method (cont.)*  
     Coolant Concentration / Freeze Point.....209  
     Fan Clutch.....210

**H**

Hazard Warning Light Switch.....76  
 Hazard Warning Switch.....165  
 Hazards of Diesel Fuel / Gasoline Blends.....130  
 HD-OBD Foreword.....5  
 HD-OBD Overview.....130  
 Headlight Switch.....75  
 Headlight Switch and Panel Lighting Control.....75  
     Automatic Headlights.....76  
     Headlight Switch.....75  
     Panel Lighting Control.....76  
 Heater and Coolant Hose Inspection and Replacement  
     Guide.....210  
 Heater Booster Pump.....125  
 Heater Control Switch.....121  
 Heater Cut-Off Valve.....125  
 Heater System.....119, 212  
     Auxiliary Heaters.....120  
     Driver Heater.....119  
 Heating Mode.....122  
 HI / LO Beam.....78  
 High Restriction Reading Table.....204  
 Horizontal Emergency Exit Window.....92  
 Horn.....61  
 Hot Weather Operation.....146  
 Hub-Piloted Wheel Installation Procedures.....224  
 Hydraulic Brake Fluid Accumulators.....199  
 Hydraulic Brakes.....147

## H (CONT.)

<i>Hydraulic Brakes (cont.)</i>	
Power Parking Brake System.....	149
To Manually Apply The Powered Parking Brake.....	150
To Manually Release The Powered Parking Brake.....	150
Split-System Feature.....	148
Using the Full Power Brake System.....	147
Warning Indicators.....	148
Hydraulic Full Power Brakes.....	197
ABS Connections and Sensors.....	199
Brake Fluid Level.....	198
Brake Inspection and Adjustment.....	197
Brake Lines, Hoses, and Fittings.....	198
Fluid Precautions.....	198
Hydraulic Brake Fluid Accumulators.....	199

## I

IMMI® Seats Tether Installation.....	111
Installing Tether.....	111
Location and Use of Tether Anchors (BTI Bus Seats).....	111
Location and Use of Tether Anchors (SafeGuard® XChange Bus Seats).....	112
Indiana Mills and Manufacturing Inc. (IMMI®) Integrated Child Restraint Seats (Optional).....	105
Indicators about DEF Quality Problem (For Vehicles Equipped with Cummins® ISB Engines) Table.....	138
Indicators about Low DEF level (For Vehicles Equipped with Cummins® ISB Engines) Table.....	135
Inspection.....	220
Inspection Check Lists.....	16
Auxiliary Fuel-Fired Heater System.....	24
Brakes.....	18
Emergency Exits and Equipment.....	24

## I (CONT.)

<i>Inspection Check Lists (cont.)</i>	
Exterior Checks.....	16
Front Suspension.....	18
Integrated Air Conditioning System (IC Air).....	23
Interior Visual and Operational Checks.....	21
Underhood and Fluid Checks.....	19
Inspection of Seat Belts.....	101
Installation.....	226
Installing Tether.....	111
Instructions.....	145
Instrument Panel Gauge Audible Alarms.....	57
Audible Alarms Table.....	57
Instrument Panel Gauge Cluster.....	27, 33
Direct Drive Warning Indicators.....	34
Instrument Panel Gauge Audible Alarms.....	57
Instrument Panel Gauge Cluster.....	33
Integral Digital Display.....	35
Integral Digital Display Detailed Information.....	37
Optional Instrument Panel Gauge Cluster Compass	
Calibration Procedure.....	51
Compass Declination Zone Set Procedure.....	51
Compass Directional Calibration Procedure.....	54
Outside Temperature and Compass Displays (Optional).....	49
Outside Temperature Reading.....	50
User Switches.....	56
Warning Indicators.....	30
Integral Digital Display.....	35
Integral Digital Display Detailed Information.....	37
Quadrant 1: Informational Displays.....	37
Quadrant 2 Text and Warning Messages.....	42
Warning Messages.....	49
Integrated Air Conditioning (IC Air) System.....	212

*I (CONT.)*

Integrated Air Conditioning System (IC Air).....23, 123  
 Integrated Air Conditioning System (IC Air) Table.....23  
 Integrated Air Conditioning System (IC Air) Table.....23  
 Integrated Child Restraint Seats (Optional).....104  
 Indiana Mills and Manufacturing Inc. (IMMI®) Integrated Child  
 Restraint Seats (Optional).....105  
 Interior.....182  
 Flooring.....183  
 Interior Light Bar Cleaning.....182  
 Upholstery Care.....182  
 Interior (Dome) Lights.....76  
 Interior Light Bar Cleaning.....182  
 Interior Visual and Operational Checks.....21  
 Interior Visual and Operational Checks Table.....21  
 Interior Visual and Operational Checks Table.....21  
 International® Ride Optimized Suspension (IROS) (If  
 Equipped).....158  
 Introduction.....9, 120, 133  
 BE / CE Bus Front View.....10  
 BE / CE Bus Rear View.....11  
 BE Bus Left View.....13  
 BE Bus Right View.....12  
 CE Bus Left View.....15  
 CE Bus Right View.....14  
 Irregular Wear.....222

**L**

Lane Change.....77  
 Left Console Switch Panel.....62  
 Power Outlet.....66  
 Rocker Switches and Their Functions.....62

*L (CONT.)*

Line Set Ticket.....2  
 Loads.....220  
 Location and Use of Lower LATCH Anchors.....110  
 Location and Use of Tether Anchors (BTI Bus Seats).....111  
 Location and Use of Tether Anchors (SafeGuard® XChange Bus  
 Seats).....112  
 Location of the Tether Anchor (Optional).....110  
 Low DEF Level.....134  
 Lowering the Hood.....177  
 Lubricant and Sealer Specifications.....241  
 Lubricant and Sealer Specifications Table.....241  
 Lubricant and Sealer Specifications Table.....241  
 Lubrication and Maintenance Interval Chart Notes.....228  
 Lubrication and Maintenance Interval Chart Symbols Key...228  
 Lubrication and Maintenance Interval: Bus — Recommended  
 Synchronized Intervals Table.....229  
 Lubrication Points.....214

**M**

Maintenance Guidelines.....185  
 Maintenance Intervals.....227  
 Lubrication and Maintenance Interval Chart Notes.....228  
 Lubrication and Maintenance Interval Chart Symbols  
 Key.....228  
 Lubrication and Maintenance Interval: Bus — Recommended  
 Synchronized Intervals Table.....229  
 Mirror Adjustment.....71

**N**

Navistar, Inc., Warranty Program.....251  
 No Restriction Reading Table.....204

**O**

Opening / Closing.....	81
Opening Speed Adjustment.....	191
Opening the Entrance Door.....	83
Air-Actuated Door.....	83
Electric-Actuated Door.....	83
Opening the Entrance Door Manually.....	83
Opening the Entrance Door Manually.....	83
Operation.....	71, 121
Operational Modes.....	133
Optional Air Suspension Seat.....	97
Optional Instrument Panel Gauge Cluster Compass Calibration Procedure.....	51
Compass Declination Zone Set Procedure.....	51
Compass Directional Calibration Procedure.....	54
Optional Rocker Switches.....	85
Outside Temperature and Compass Displays (Optional).....	49
Outside Temperature Reading.....	50
Quadrant 4: Transmission Gear Displays.....	50

**P**

Panel Lighting Control.....	76
Parked Regeneration Procedure.....	144
Parking Brake / Wheelchair Lift (Optional) Alarm.....	154
Parking Brake / Wheelchair Lift Interlock and Alarm.....	154
Parking Brake / Wheelchair Lift (Optional) Alarm.....	154
Parking Brake / Wheelchair Lift Interlock–Retracting and Stowing Operation.....	154
Wheelchair Lift Extension Operation.....	154
Parking Brake / Wheelchair Lift Interlock–Retracting and Stowing Operation.....	154
Parking Brake Indicator Light.....	153

**P (CONT.)**

Parking the Bus With Transmission Shift / Wheelchair Lift Interlocks.....	162
Wheelchair Lift Extension Operation.....	162
Parking the Vehicle.....	161
Passenger Seat Belts.....	101
CE White Integrated Child Restraint Seats (Optional).....	107, 109
Child Restraint Anchorage Systems (Optional).....	109
Location and Use of Lower LATCH Anchors.....	110
Cushion Release Latch.....	112
IMMI® Seats Tether Installation.....	111
Installing Tether.....	111
Location and Use of Tether Anchors (BTI Bus Seats).....	111
Location and Use of Tether Anchors (SafeGuard® XChange Bus Seats).....	112
Integrated Child Restraint Seats (Optional).....	104
Location of the Tether Anchor (Optional).....	110
Passenger Three-Point Seat Belts (Optional).....	102
39 Inch Flex Seat.....	104
Buckling Up.....	102
Unbuckling.....	103
Passenger Two-Point Seat Belt (Lap Belts).....	102
Passenger Three-Point Seat Belts (Optional).....	102
39 Inch Flex Seat.....	104
Buckling Up.....	102
Unbuckling.....	103
Passenger Two-Point Seat Belt (Lap Belts).....	102
Pedal Adjustment.....	157
Post-Trip Inspection (No Student Left Behind).....	87
Snooze Mode.....	88
System Activation.....	87

**P (CONT.)**

*Post-Trip Inspection (No Student Left Behind) (cont.)*

- System Deactivation..... 88
- System Function..... 87
- System Purpose..... 87
- Power Outlet..... 66
- Power Parking Brake System..... 149
  - To Manually Apply The Powered Parking Brake..... 150
  - To Manually Release The Powered Parking Brake..... 150
- Power Steering..... 215
- Power Steering System..... 239
  - Power Steering Systems Table..... 239
- Power Steering Systems Table..... 239
- Pre-Trip and Post-Trip Inspections..... 187
- Preface..... 1, 185
- Pressure Regulator Adjustment..... 191

**Q**

- Quadrant 1: Informational Displays..... 37
- Quadrant 2 Text and Warning Messages..... 42
- Quadrant 4: Transmission Gear Displays..... 50

**R**

- Raising the Hood..... 176
- Rear Axle – Inspection and Lubrication..... 193
- Reflective Triangle..... 167
- Regeneration..... 217
- Regeneration Inhibit Switch..... 144
- Removal..... 226
- Reporting Safety Defects..... 4
  - Canadian Registered Vehicles..... 5
  - U.S. Registered Vehicles..... 4
- Reserve Fuel..... 132

**R (CONT.)**

- Restarting After Running Out of Fuel..... 132, 145
- Retracting and Stowing Operation..... 162
- Right Console Switch Panel..... 68
  - Rocker Switches and Their Functions..... 68
- Rocker Switches and Their Functions..... 62, 68
- Roof Vent / Hatch..... 93
- Rotation..... 221
  - Rotation Is Advisable..... 221
  - Tire Replacement..... 221
- Rotation Is Advisable..... 221

**S**

- Safety Recalls and Authorized Field Changes..... 5
- Scheduled Maintenance..... 201
- Seat Base Bolts..... 250
- Seat Belt Cutter..... 101
- Seat Belt Tether..... 99
  - Tether Adjuster Procedure..... 99
- Seat Height Adjustment..... 96
- Selective Catalytic Reduction System (If Equipped)..... 133
  - DEF Contamination or SCR System Fault..... 137
  - DEF Tank..... 134
  - Diesel Exhaust Fluid..... 133
  - Indicators about DEF Quality Problem (For Vehicles Equipped with Cummins® ISB Engines) Table..... 138
  - Indicators about Low DEF level (For Vehicles Equipped with Cummins® ISB Engines) Table..... 135
- Introduction..... 133
- Low DEF Level..... 134
- Warnings of SCR System Fault (For Vehicles Equipped with Cummins® ISB Engines) Table..... 139
- Self Diagnostics..... 130

## S (CONT.)

Service Information.....	251
Signaling for a Turn.....	77
Snooze Mode.....	88
Split-System Feature.....	148
Standard Allison 1000 PTS Transmission.....	158
Starting Bus in Motion.....	162
Starting Bus in Motion With Transmission Shift / Wheelchair Lift Interlocks.....	162
Starting Procedures.....	127
Starting the Engine.....	127
Automatic Transmission Starter Interlock.....	128
Starting the Engine.....	127
Automatic Transmission Starter Interlock.....	128
Steering.....	213
General.....	213
Lubrication Points.....	214
Power Steering.....	215
Tightening Steering Intermediate Shaft Joint Bolts.....	214
Steering Column Pinch Bolts Torque Chart.....	248
Steering Wheel and Column.....	60
Adjustable Tilt Steering Column.....	61
Horn.....	61
Steering Wheel Controls (BE Optional and CE Standard).....	60
Steering Wheel Controls (BE Standard and CE Optional).....	61
Steering Wheel Controls (BE Optional and CE Standard).....	60
Steering Wheel Controls (BE Standard and CE Optional).....	61
Storage Duration – One Month or Less.....	3
Storage Duration–Over One Month.....	3
Strobe Light.....	78
Supplemental Federal Emission Control System Maintenance, Repair, and Replacement.....	6

## S (CONT.)

Supplemental Federal Emission Control System Warranty.....	5
Additional Components Covered.....	6
GHG Emission Control System Warranty Period.....	6
Supplemental Federal Emission Control System Maintenance, Repair, and Replacement.....	6
Supporting Your Vehicle for Service.....	187
Surface Cleaning.....	181
ABS / Plastic.....	182
General Cleaning, All Surface Types.....	181
Glass.....	182
Suspension (Air and Steel Springs).....	213
Switch Location.....	78
Switching-Off Sequence.....	123
System Activation.....	87
System Deactivation.....	88
System Function.....	87
System Purpose.....	87

## T

Terminal Inspection–Cleaning–Corrosion Protection.....	199
Tether Adjuster Procedure.....	99
Three-Position Door Switch.....	82
Three-Position Regeneration Inhibit Switch.....	145
Tightening Steering Intermediate Shaft Joint Bolts.....	214
Tilt Hood.....	176
Lowering the Hood.....	177
Raising the Hood.....	176
Tire and Rim Combinations.....	240
Approved Tire and Wheel Combinations Table.....	240
Tire Maintenance.....	219
Checking Inflation.....	219
Underinflation.....	220

*T (CONT.)*

Tire Replacement.....221

Tire Warnings.....218

Tires.....218

    Dual Tires Matching.....221

    Dual Tires Mixing.....221

    Inspection.....220

    Loads.....220

    Rotation.....221

        Rotation Is Advisable.....221

        Tire Replacement.....221

    Tire Maintenance.....219

        Checking Inflation.....219

        Underinflation.....220

    Tire Warnings.....218

    Use of Tire Chains.....222

    Wear.....222

        Irregular Wear.....222

    Wheel and Tire Balancing.....222

To engage Air Parking Brake.....152

To Manually Apply The Powered Parking Brake.....150

To Manually Release The Powered Parking Brake.....150

To release Air Parking Brake.....152

Torque Specification Charts.....248

    Axle U-Bolt Nut Torque Chart.....249

    Disc Wheels Torque Chart.....248

    Seat Base Bolts.....250

    Steering Column Pinch Bolts Torque Chart.....248

    Wiper Arm Torque Chart.....250

Towing Instructions.....178

    Towing Preparation: Air Parking Brakes.....179

    Towing Preparation: Hydraulic-Powered Parking Brakes.....179

*T (CONT.)*

*Towing Instructions (cont.)*

    Towing Vehicle With Front Wheels Suspended.....180

    Towing Vehicles With Rear Wheels Suspended.....180

Towing Preparation: Air Parking Brakes.....179

Towing Preparation: Hydraulic-Powered Parking Brakes.....179

Towing Vehicle With Front Wheels Suspended.....180

Towing Vehicles With Rear Wheels Suspended.....180

Track Seat Mounting Seat Type Specific.....114

Traction Control (If Equipped).....157

Traffic Warning System.....83

    Eight-Lamp Amber and RED Warning Lights.....84

    Electronic Safety Messages.....84

    Optional Rocker Switches.....85

    WIG WAG Warning System.....86

Transmission.....217, 239

    Transmission Fluid Level.....217

    Transmission Table.....239

Transmission Fluid Level.....217

Transmission Table.....239

Transmission, Parking Brake, and Ignition Switch Panel.....66

Troubleshooting.....204

Turn Signal.....60

Turn Signal Switch.....76

    HI / LO Beam.....78

    Lane Change.....77

    Signaling for a Turn.....77

Turning Off the Engine.....147

Two-Position Door Switch.....82

Two-Position Regeneration Inhibit Switch.....145

Typical Interior Fuse Panel Layout.....172

    Fuse Panel Layout, Sheet 1.....172

    Fuse Panel Layout, Sheet 2.....173

## Index

---

### T (CONT.)

<i>Typical Interior Fuse Panel Layout (cont.)</i>	
Fuse Panel Layout, Sheet 3.....	174
Fuse Panel Layout, Sheet 4.....	175

### U

U.S. Registered Vehicles.....	4
Ultra-Low Sulfur Diesel Fuel Requirements.....	130
Unacceptable Fuel Blends.....	130
Unbuckling.....	103
Underhood and Fluid Checks.....	19
Underhood and Fluid Checks Table.....	20
Underhood and Fluid Checks Table.....	20
Underinflation.....	220
Unit Refill Capacities.....	238
Air Conditioner Refrigerant.....	238
Cooling System Refill Capacities.....	238
Diesel Exhaust Fluid Tank.....	238
Engine Crankcase.....	239
Full Power Brakes – Brake Fluid.....	239
Power Steering System.....	239
Transmission.....	239
Unloading Students With Engine Off.....	89
Upholstery Care.....	182
Use of Tire Chains.....	222
User Switches.....	56
Using Air Brakes.....	152
Using the Air Parking Brake.....	152
Air Brake Gauge.....	153
To engage Air Parking Brake.....	152
To release Air Parking Brake.....	152
Using the Full Power Brake System.....	147

### V

Vehicle Identification.....	1
Vehicle Storage Instructions.....	2
Diesel Exhaust Fluid (DEF) Storage.....	4
Storage Duration – One Month or Less.....	3
Storage Duration–Over One Month.....	3
Vertical Emergency Exit Window.....	92

### W

Warning Indicators.....	30, 148
Warning Messages.....	49
Warnings of SCR System Fault (For Vehicles Equipped with Cummins® ISB Engines) Table.....	139
Waxing or Polishing Vehicles.....	184
Wear.....	222
Irregular Wear.....	222
Wheel and Tire Balancing.....	222
Wheel and Wheel Nut Maintenance and Installation.....	223
Hub-Piloted Wheel Installation Procedures.....	224
Wheel Nut Torque Maintenance.....	224
Wheel Nut Torque Maintenance.....	224
Wheelchair Lift Alarm.....	91
Wheelchair Lift Extension Operation.....	154, 162
Wheelchair Lift Interlocks – Extending.....	90
Wheelchair Lift Interlocks–Retracting and Stowing.....	90
Wheelchair Lift Operation.....	90
Wheelchair Lift Alarm.....	91
Wheelchair Lift Interlocks – Extending.....	90
Wheelchair Lift Interlocks–Retracting and Stowing.....	90
Wheels.....	223
Wheel and Wheel Nut Maintenance and Installation.....	223
Hub-Piloted Wheel Installation Procedures.....	224



**W (CONT.)**

*Wheels (cont.)*  
Wheel Nut Torque Maintenance.....224  
WIG WAG Warning System.....86  
Windshield Washer.....59  
Windshield Wiper.....225  
Wiper Blade Assembly Replacement.....225  
Windshield Wiper / Washer System.....59  
Windshield Washer.....59  
Windshield Wiper Speed Control.....59  
Wiper Blade Speed.....59

**W (CONT.)**

Windshield Wiper Speed Control.....59  
Winter Fronts.....146  
Wiper Arm Removal / Replacement.....226  
Installation.....226  
Maintenance Intervals.....227  
Removal.....226  
Wiper Arm Torque Chart.....250  
Wiper Blade Assembly Replacement.....225  
Wiper Blade Speed.....59