



MODULE 7 PRODUCT SUPPORT CUSTOMER TRAINING

# VII HYBRID SAFETY PROGRAM

0446

## NUMBER ONE PRIORITY

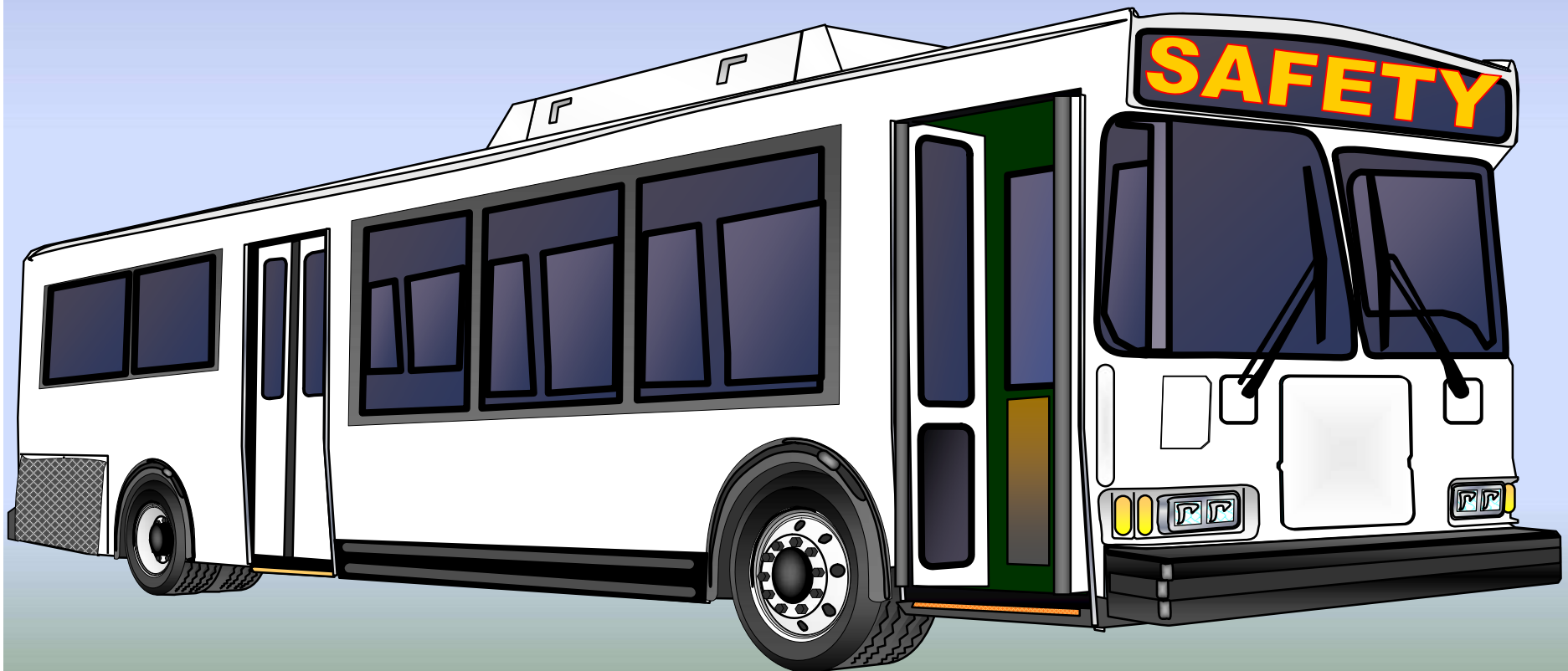

## - PERSONAL SAFETY





# VII HYBRID SAFETY

## n SERVICE MANUAL PRECAUTIONS

 <b>NOTE</b>	<p><i>RENDERS ADDED INFORMATION THAT WILL HELP COMPLETE, OFFER AN ALTERNATIVE, OR RATIONALIZE A PARTICULAR JOB OR PROCEDURE.</i></p>
<b>CAUTION !</b>	<p><i>ANY PREVENTATIVE ADVICE TO AVOID MAKING ERRORS THAT COULD DAMAGE THE PART, SYSTEM, VEHICLE, OR CAUSE PERSONAL INJURY.</i></p>
 <b>WARNING</b>	<p><i>INDICATES THOSE AREAS WHERE INSUFFICIENT KNOWLEDGE OF A PROCEDURE, SKILL, OR LACK OF ATTENTION COULD RESULT IN PERSONAL INJURY OR LOSS OF LIFE.</i></p>
 <b>DANGER</b>	<p><i>INDICATES AN IMMINENTLY HAZARDOUS SITUATION WHICH, IF NOT AVOIDED, WILL RESULT IN DEATH OR SERIOUS PERSONAL INJURY.</i></p>



# **VII HYBRID SAFETY**

## **HYBRID ELECTRICAL SAFETY**

0446

### **n 1274A/B HYBRID ELECTRICAL SYSTEMS**

#### **– ISOLATED VEHICLE FROM HYBRIDRIVE SYSTEMS**

- » **VEHICLE 24/12 VDC POWER DISTRIBUTION**
- » **HYBRIDRIVE OVERVIEW**
- » **HYBRIDRIVE TO VEHICLE INTERFACE**
- » **HYBRID SAFETY PRECAUTIONS**
  - **WELDING**
  - **ACCIDENTS**
  - **TOWING**
- » **SAFETY PROCEDURES**



MODULE 7 PRODUCT SUPPORT CUSTOMER TRAINING

**VI HYBRID SAFETY**

**GENERAL INFO SECTION FOR SAFETY 0446**

## **VEHICLE 24/12 VDC POWER DISTRIBUTION**

- BATTERIES TO LOWER PDC**
- LOWER PDC TO E ZONE**
- E ZONE TO:**
  - MAIN PANEL, DRIVER'S BARRIER AND RAMP**
- E ZONE TO FRONT DOOR**



# HYBRID SAFETY

## GENERAL INFO SECTION FOR SAFETY

0446

### LOWER PDC

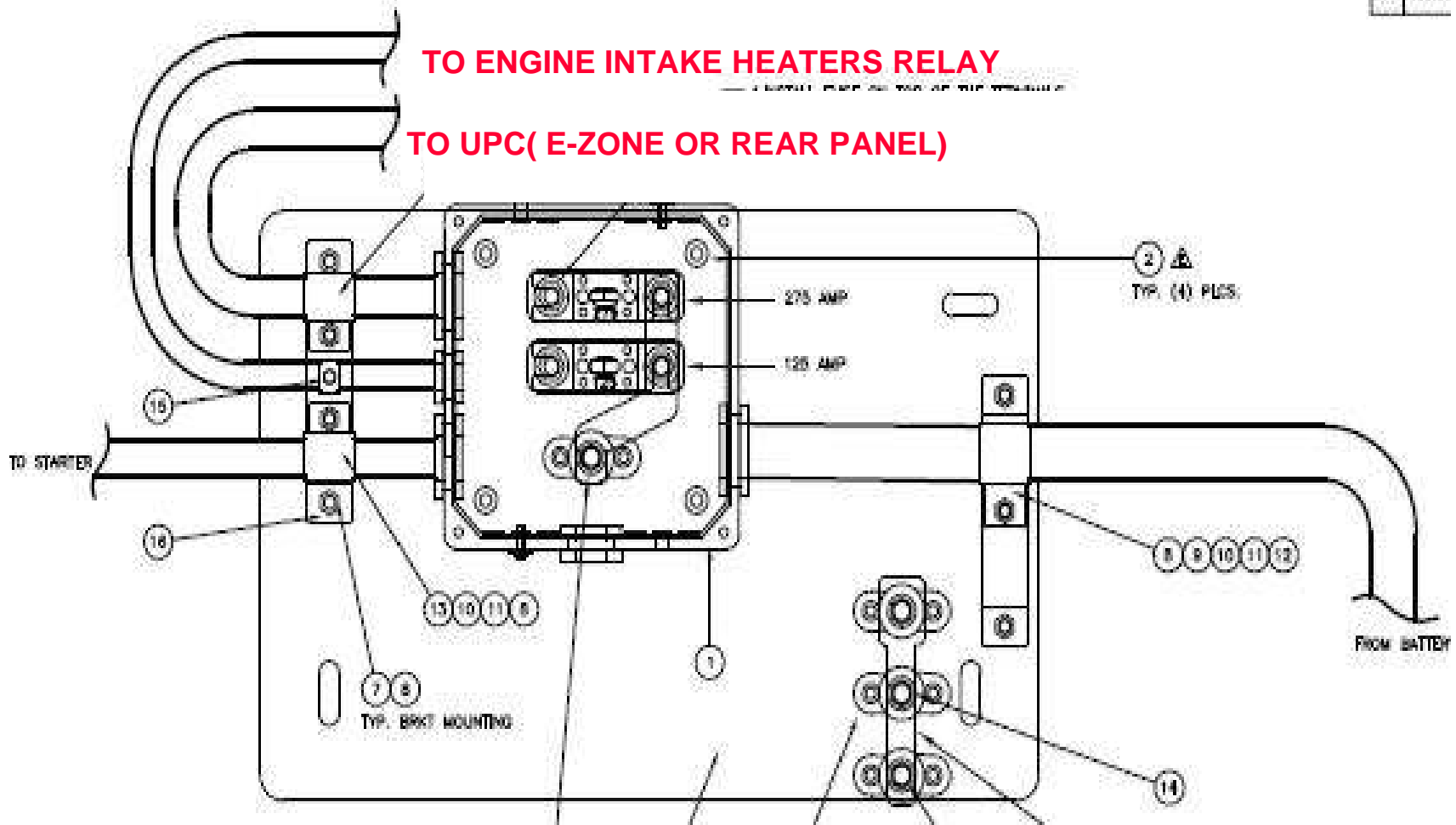

MODULE 7 PRODUCT SUPPORT CUSTOMER TRAINING

# Orion VII COMPARTMENTS & PANELS

## REAR ELECTRICAL PANEL

0446

### UPC( E-ZONE OR REAR PANEL)

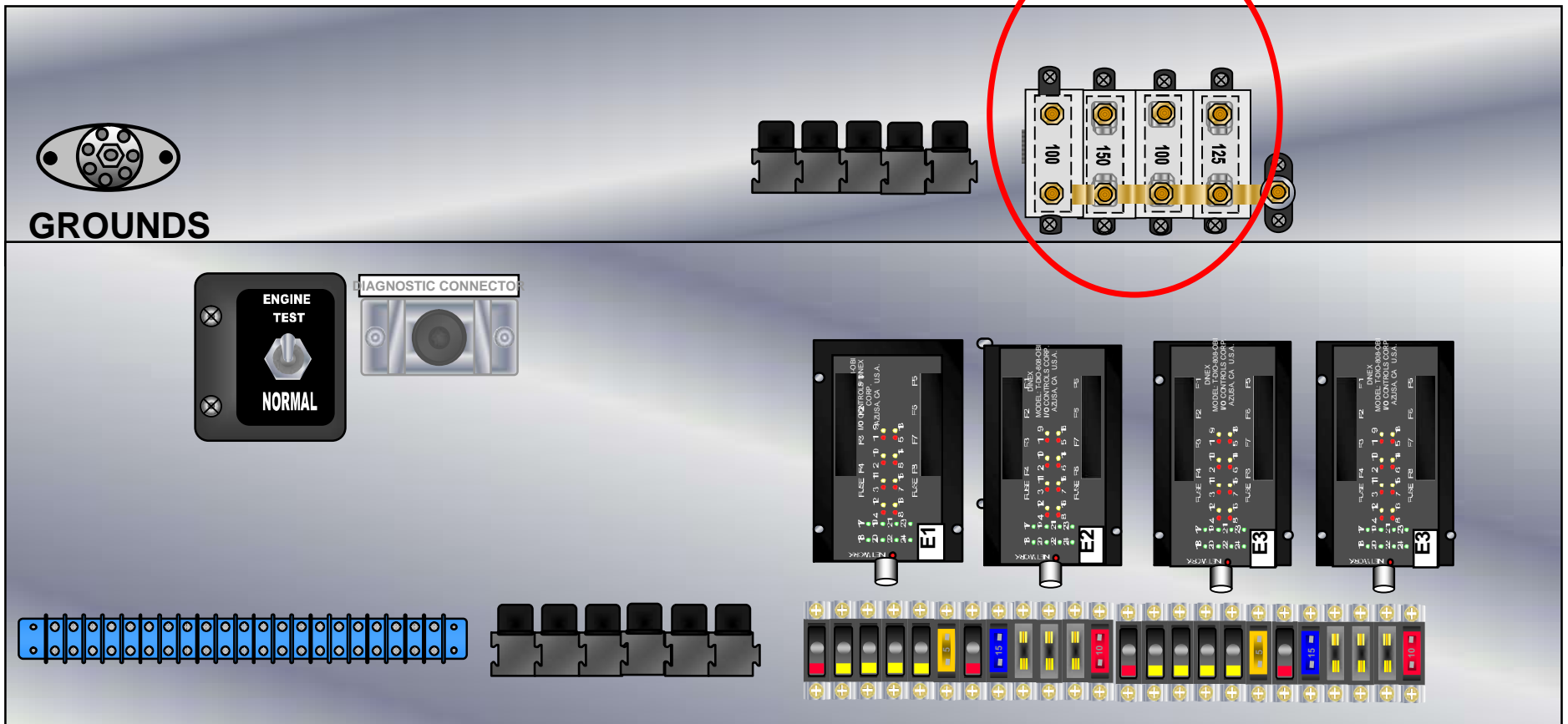

MODULE 7 PRODUCT SUPPORT CUSTOMER TRAINING

# Orion VII COMPARTMENTS & PANELS

E ZONE TO MAIN PANEL, RAMP AND DB 0446

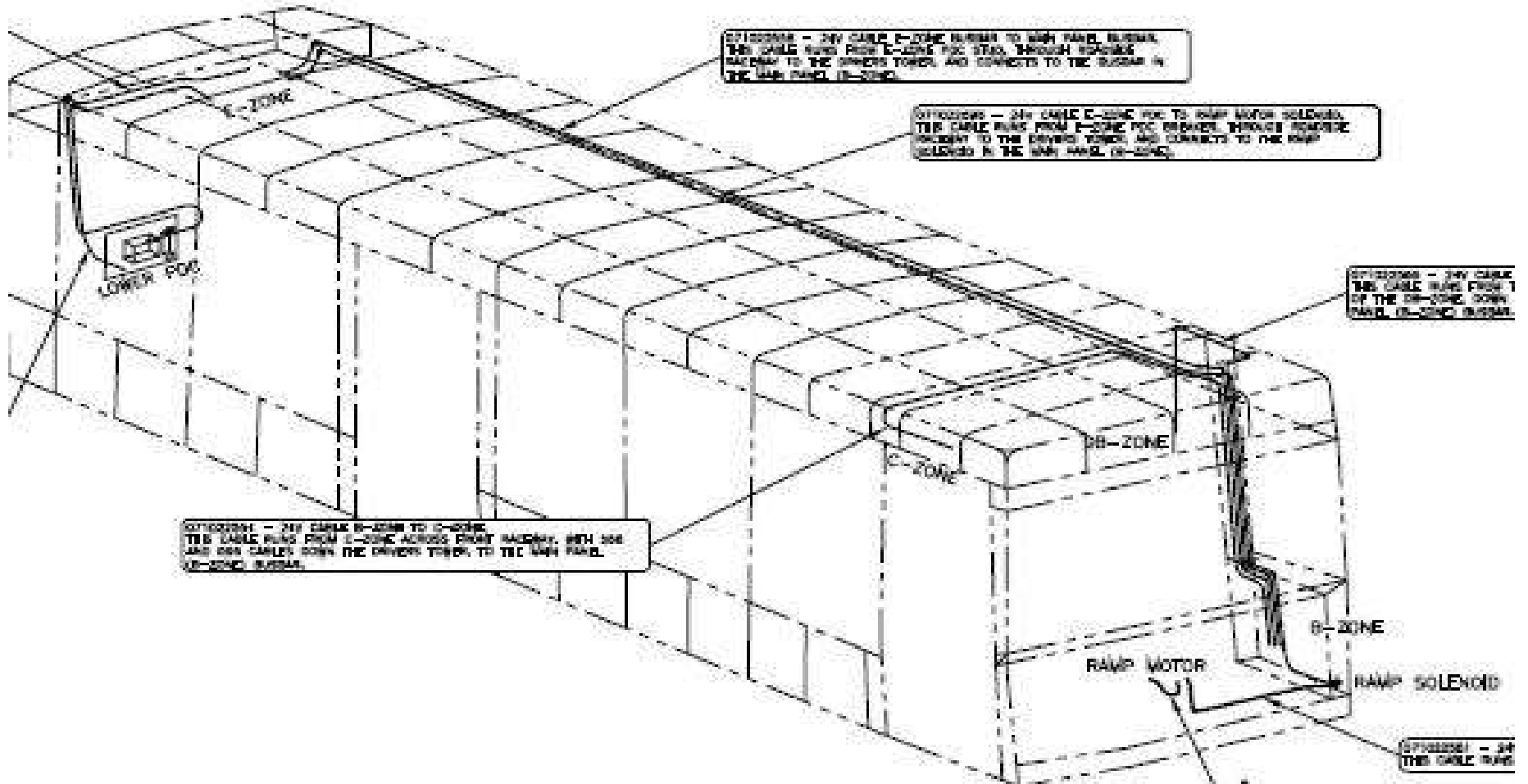

MODULE 7 PRODUCT SUPPORT CUSTOMER TRAINING

**Orion VII COMPARTMENTS/PANELS**

MAIN ELECTRICAL PANEL 0446

# FRONT OR MAIN PANEL

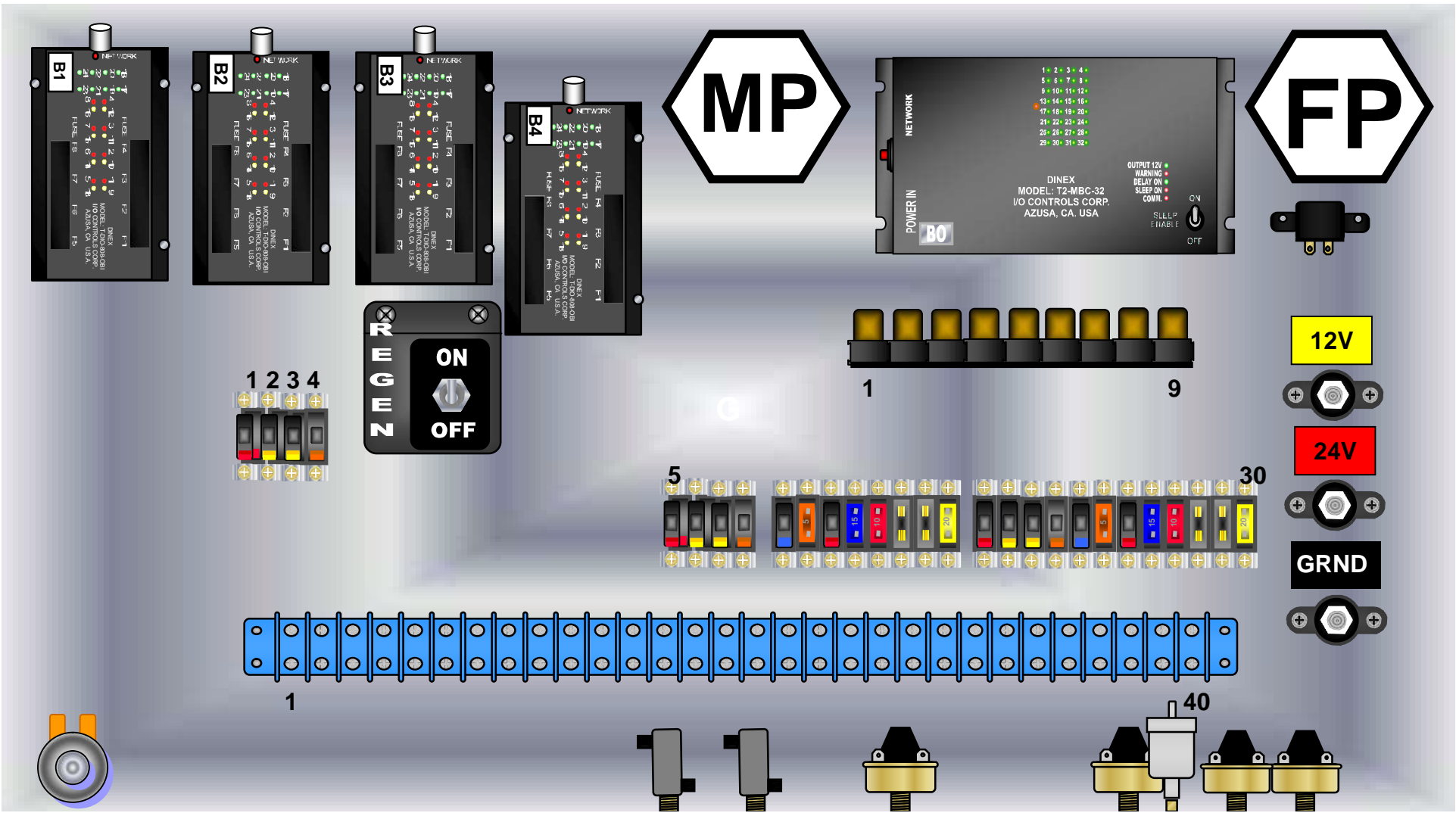



Orion **MODULE 7 PRODUCT SUPPORT CUSTOMER TRAINING**  
**VII COMPARTMENTS / PANELS**  
**ELECTRICAL PANELS** 0446

**n FRONT MECHANICAL BOX**

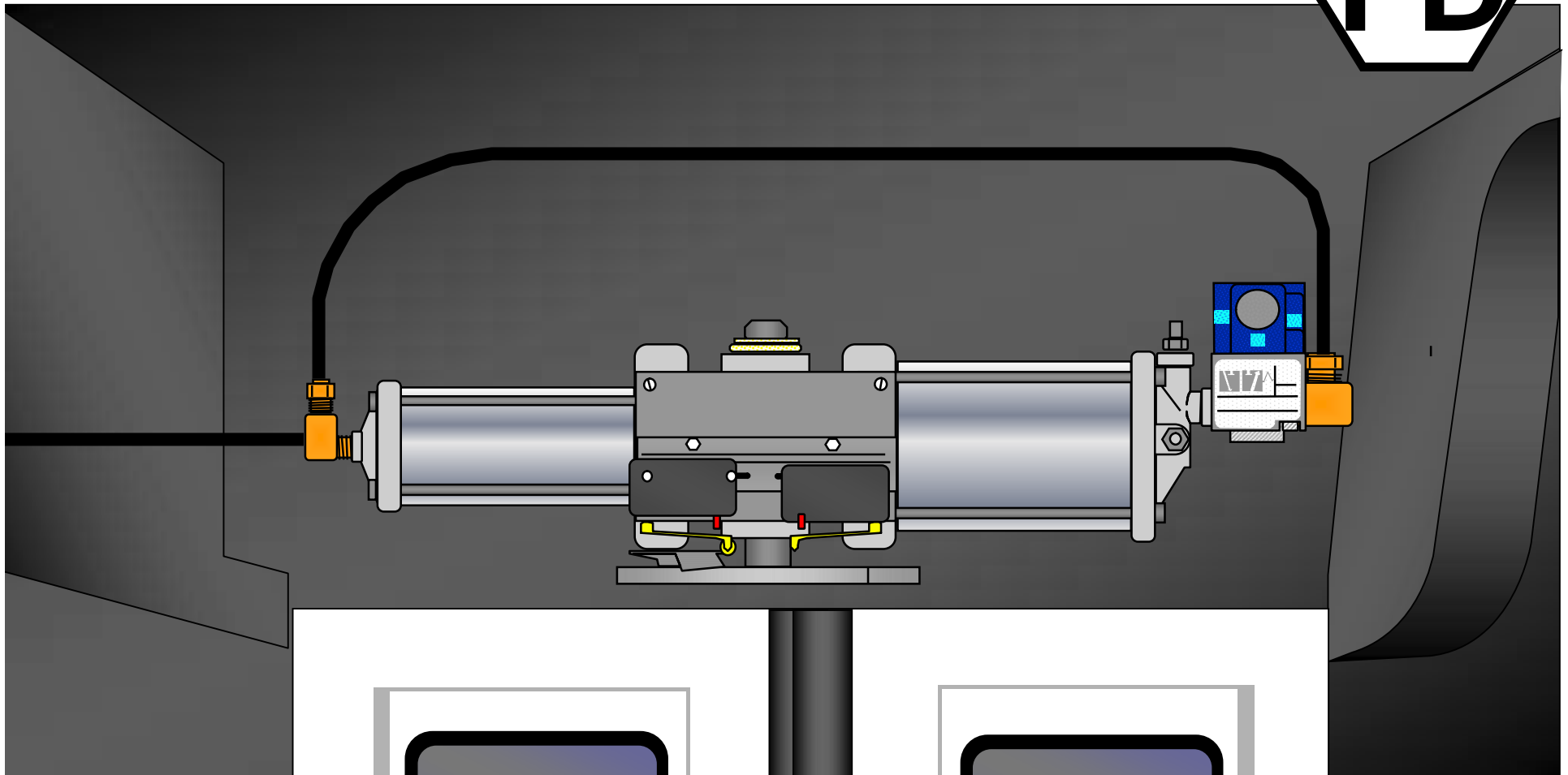



# COMPARTMENTS & PANELS

## DRIVER'S BARRIER

0446

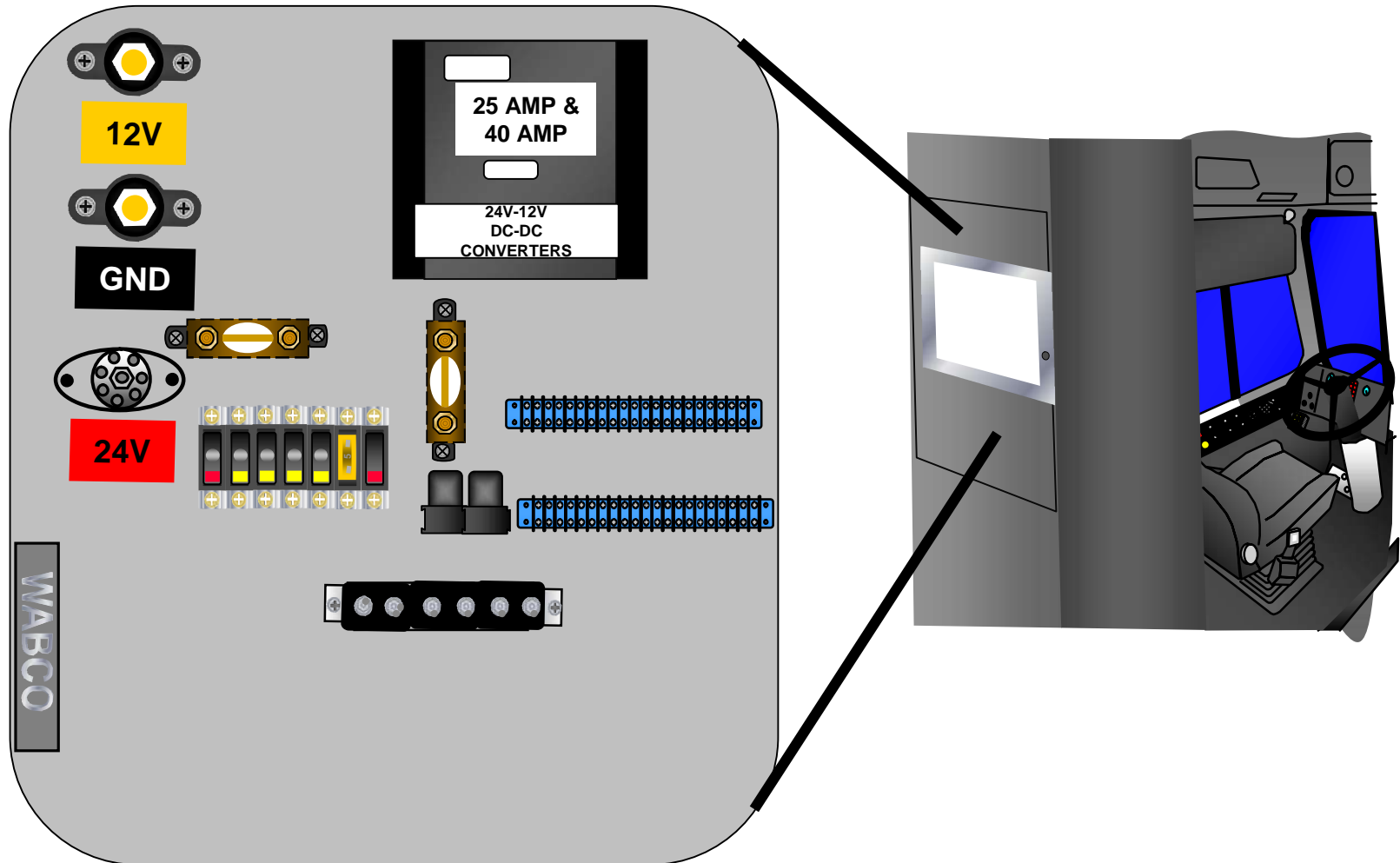

MODULE 7 PRODUCT SUPPORT CUSTOMER TRAINING



**VII** **COMPARTMENTS & PANELS**

**CURBSIDE ELECTRICAL PANEL** 0446

**n CURBSIDE PANEL**

**C ZONE**

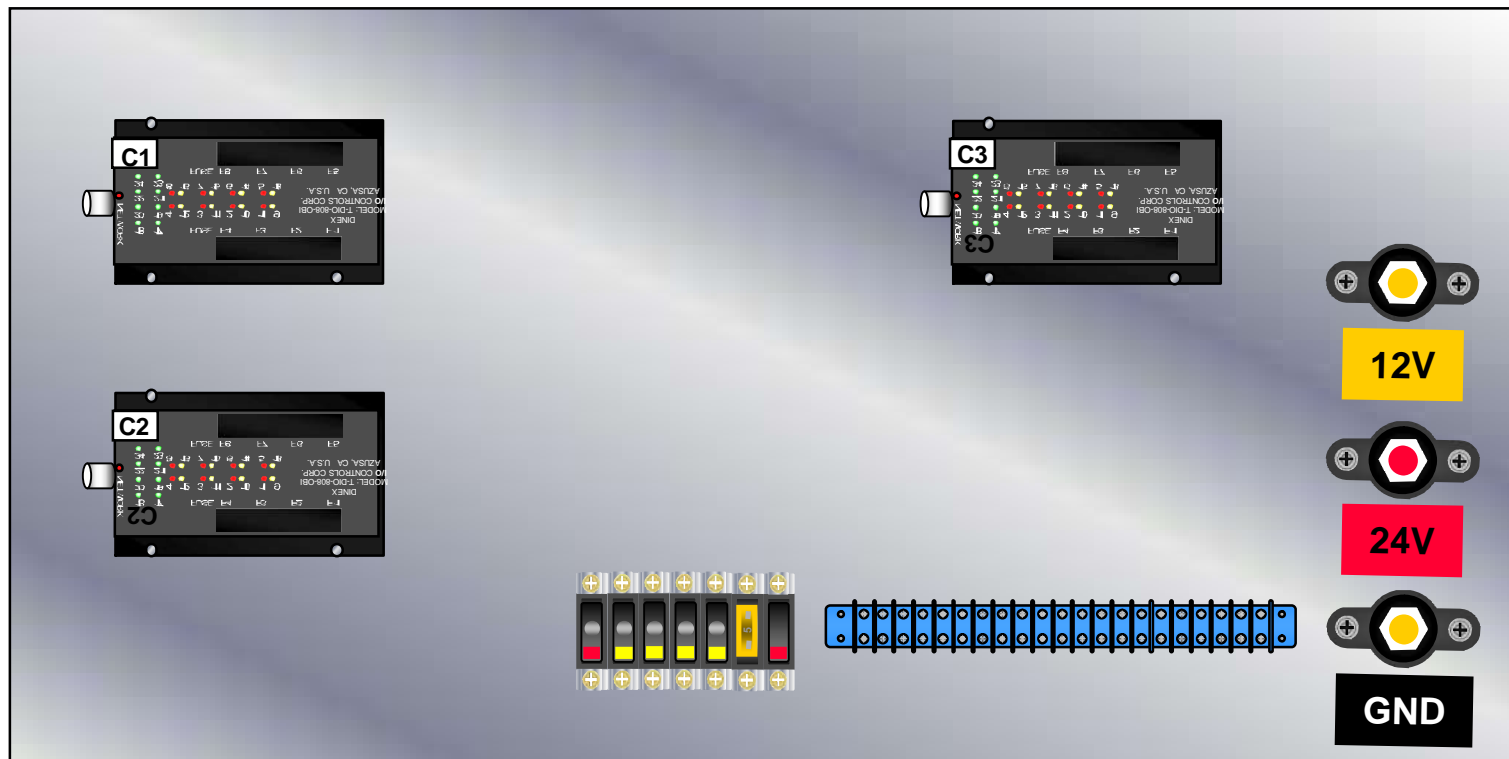

MODULE 7 PRODUCT SUPPORT CUSTOMER TRAINING

**Orion** **VII COMPARTMENTS & PANELS**

**REAR DOOR MECHANICAL BOX** 0446

- n ACCESS TO REAR DOOR MECHANICAL BOX**
  - LIMITED ACCESSIBILITY FOR CHECKS ONLY**
  - REPAIRS WILL REQUIRE LIGHT PANEL REMOVAL**

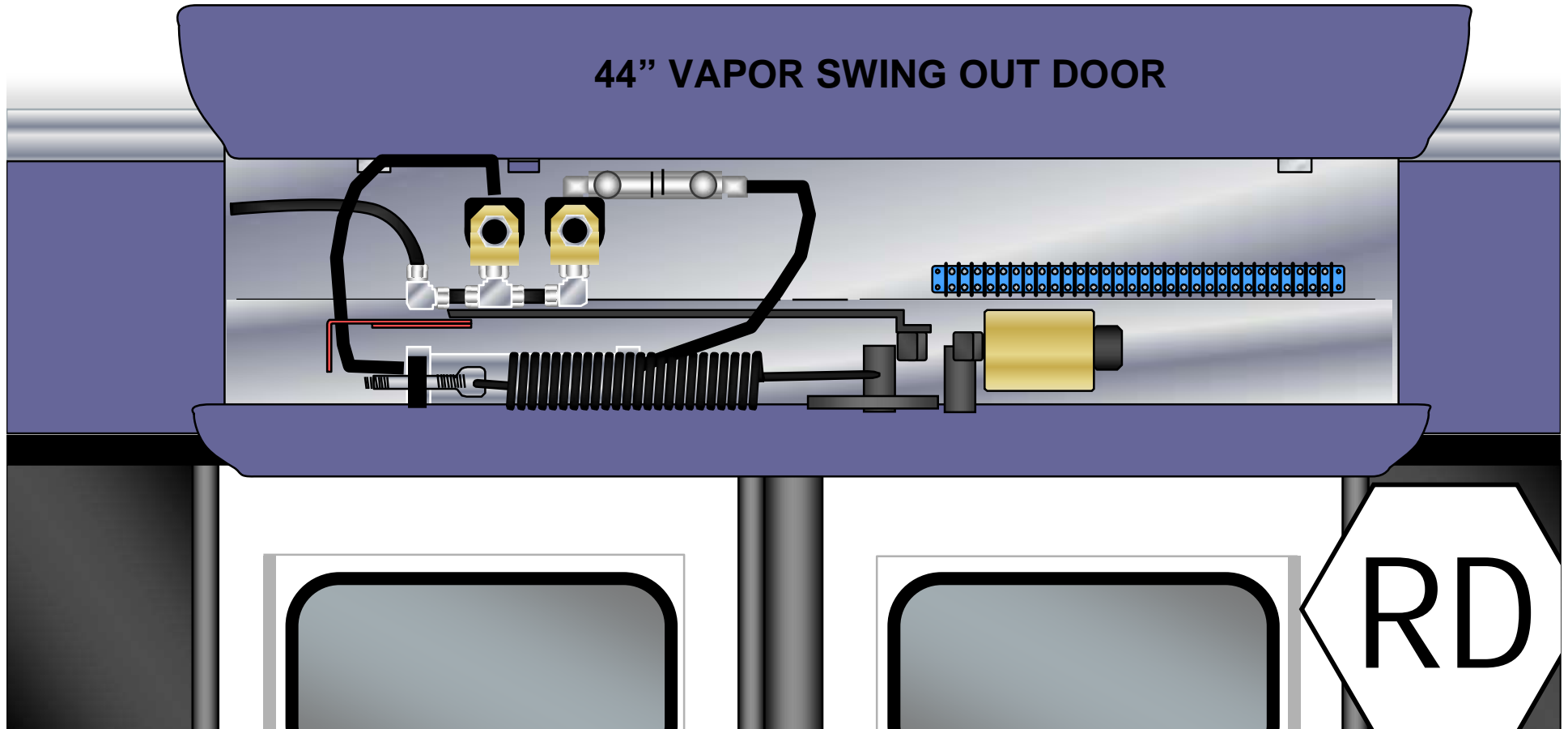

ORION  
MODULE 7 PRODUCT SUPPORT CUSTOMER TRAINING  
**VI COMPARTMENTS & PANELS**  
BATTERY COMPARTMENT 0446

**n BATTERY SLIDE OUT TRAY**

- **TWO 12'S MAKE 24 VDC**
- **BATTERY SWITCH WILL SHUT DOWN ENGINE**
- **CUTS POWER TO BATTERY TUB CONTACTORS**

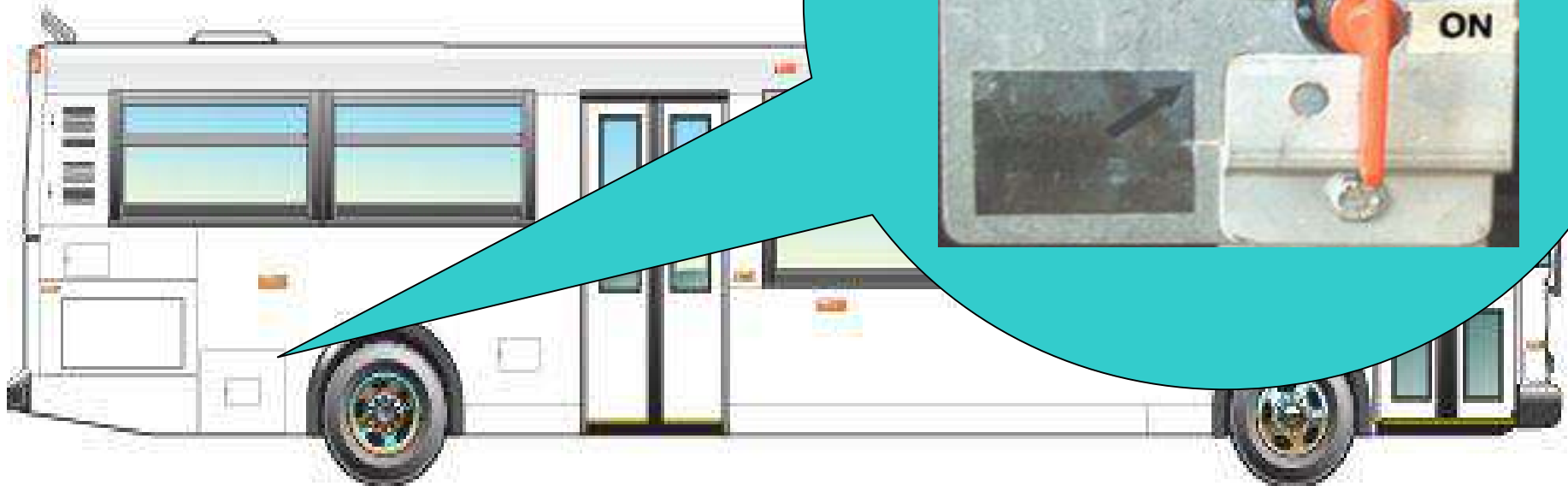

ORION **MODULE 7 PRODUCT SUPPORT CUSTOMER TRAINING**  
**VII BATTERIES & CHARGING**  
**VOLTAGE CONVERTER** 0446

## **n VOLTAGE CONVERTERS (3 EACH)**

**– PROVIDES REGULATED 12 VOLTS (APPROX. 13.8 VOLTS) FROM THE 24 VOLT BUS SYSTEM**

- » 2 IN DRIVER'S BARRIER**
- 1 UNDER DASH**

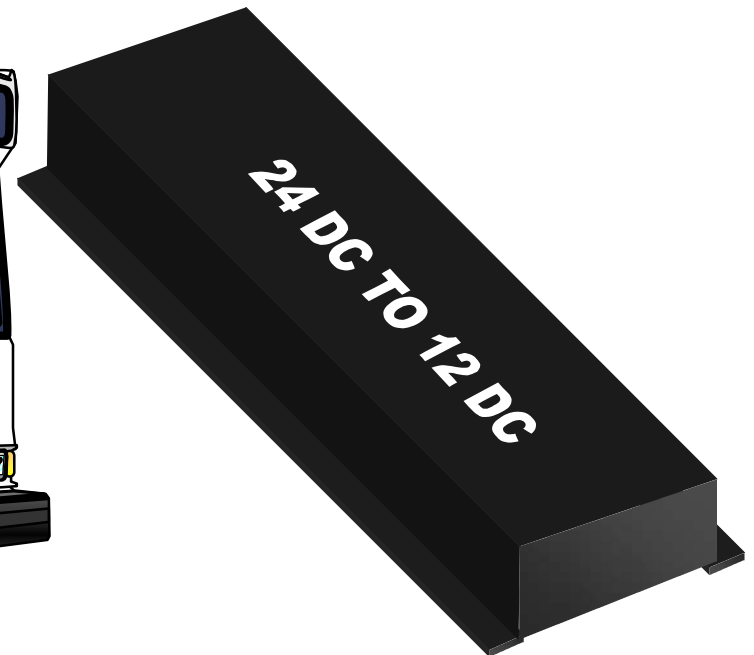



# BAE SYSTEMS Controls HYBRIDRIVE

0446



## HybriDrive™ propulsion systems

A cleaner,  
more efficient  
way to go!

BAE SYSTEMS Controls  
600 Main Street  
Johnson City, NY 13790 USA  
1-800.576.3346  
Fax 607.770.5751  
[www.na.baesystems.com/controls](http://www.na.baesystems.com/controls)

### Operating Advantages

- Up to 50% improved fuel economy
- Low emissions
  - Clean-fuel capability
- Turnkey system
  - Trouble-free performance
  - Fully integrated
  - In-depth support available to vehicle builders
- Superior drivability
- Intuitive driver interface
  - Drives like a conventional vehicle
  - Minimal operator training required
- Optimum battery management
  - Long life
  - Maintenance-free
- Advanced motor control
  - Smooth, shift-free
  - Superior energy efficiency
  - Highly reliable
- Integrated diagnostics & data logging
  - Maximizes vehicle availability
  - Useful for efficiency profiling

### Maintenance Advantages

- Reduced brake wear
- No transmission
- No clutch
- No transfer case
- Reduced engine maintenance
  - HybriDrive systems operating cycle reduces engine wear; extends oil change intervals
- Control system limits willful abuse
- Integrated diagnostics
  - Serial interface provides access via PC-based equipment
  - Simple to use
  - Inexpensive
  - Clear, intuitive, graphic user interface™

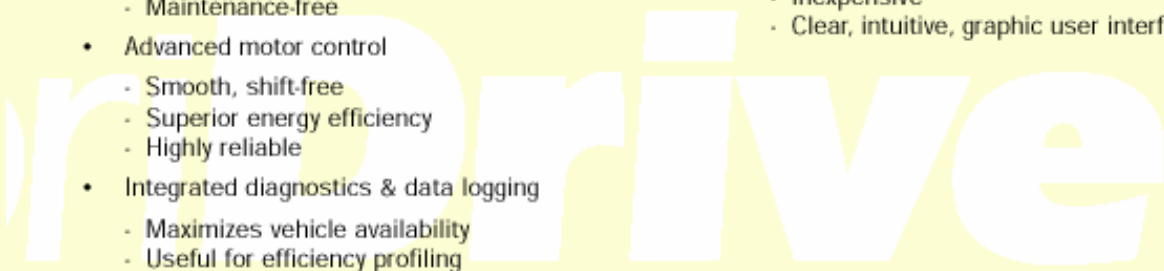

## n ELECTRICAL LAYOUT VIEW

- ELECTRICAL POWER IS SUPPLIED FROM BATTERIES AND GENERATOR TO THE PCS
- PCS DIRECTS THE ELECTRICAL POWER ON DEMAND TO THE TRACTION MOTOR
  - » ELECTRICAL ENERGY IS CONVERTED TO MECHANICAL MOTION AND SUPPLIED TO THE REAR AXLE

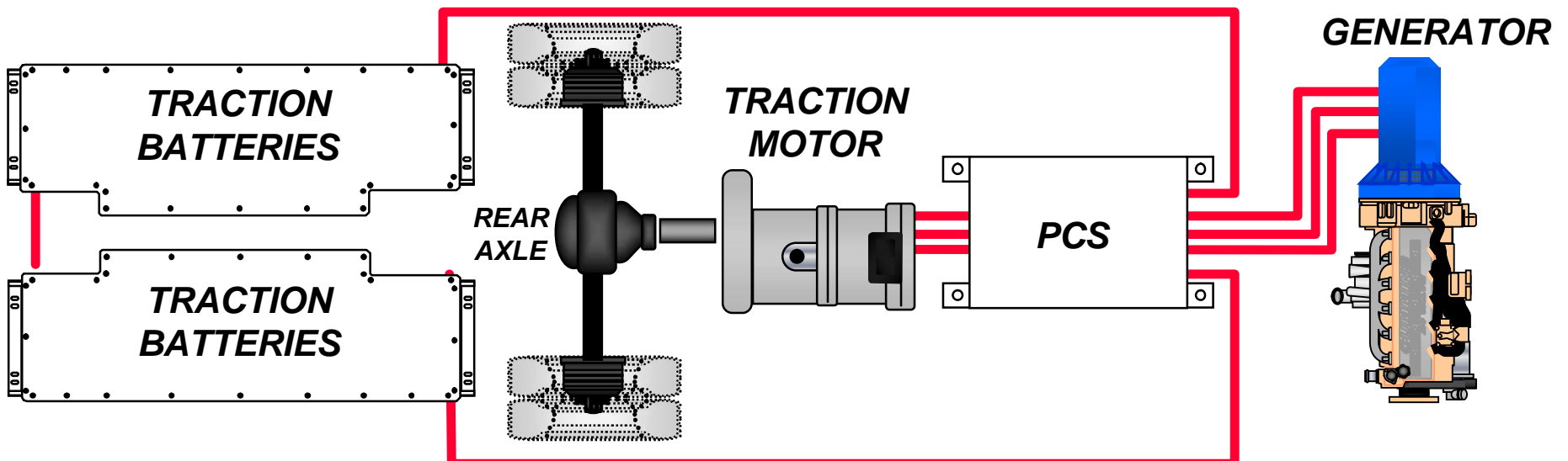





# **VII BATTERY ENCLOSURE MAINT**

0446

## **n ELECTRICAL LAYOUT VIEW**

- BATTERY TUBS**
- PCS**
- GENERATOR**
- TRACTION MOTOR**

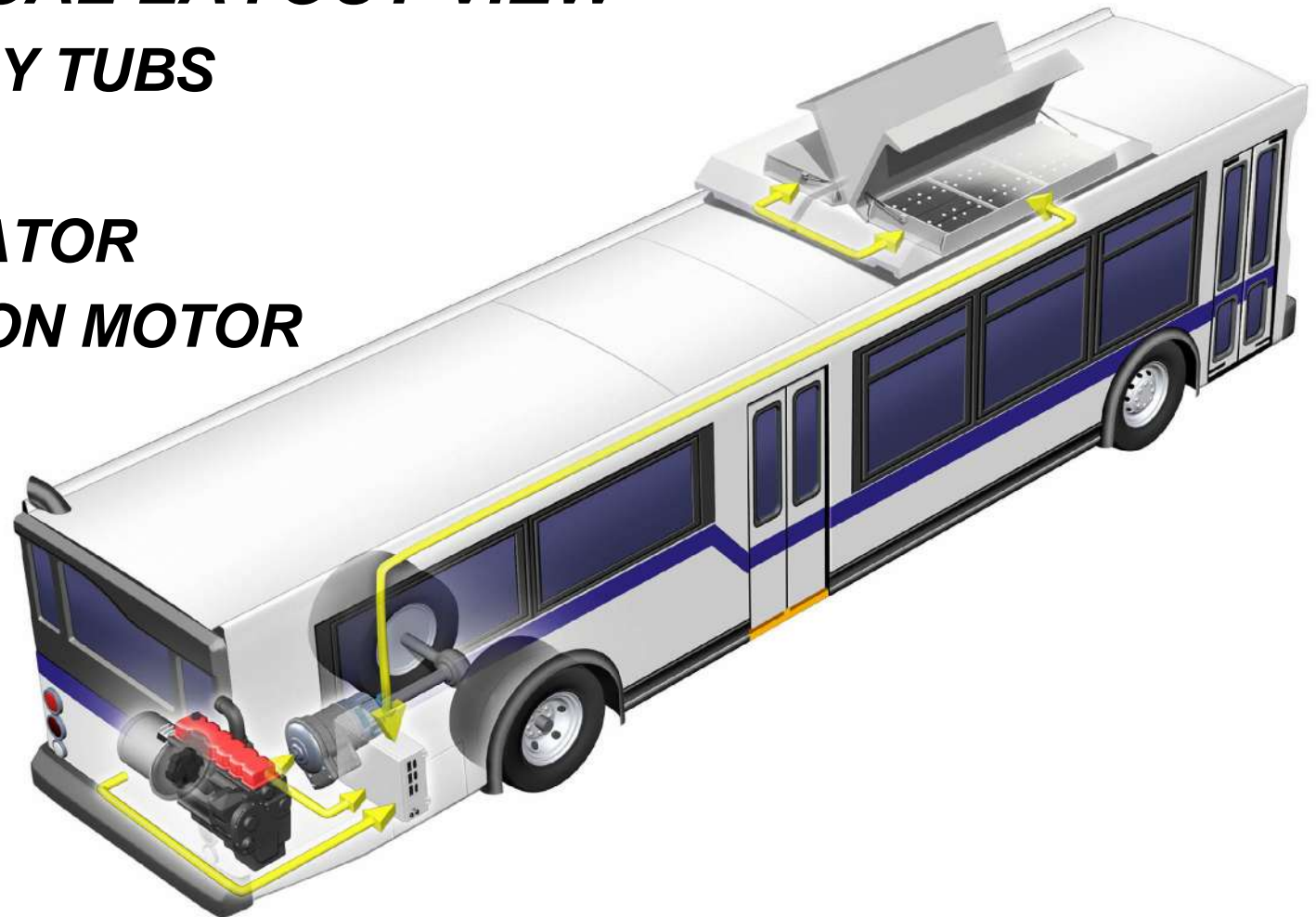



# **VII HYBRID SAFETY**

## **HIGH VOLTAGES**

0446

### **n HIGH VOLTAGES**



#### **– MOTOR, THREE PHASE**

» **MAX INPUT VOLTAGE 346 VOLTS AC, 500 HZ**

#### **– GENERATOR, THREE PHASE**

» **610 VOLTS AC, 400 HZ**

#### **– PROPULSION CONTROL SYSTEM (PCS)**

» **TIES ALL HIGH VOLTAGE COMPONENTS TOGETHER**

#### **– BATTERIES, 46 EACH**

» **500 TO 700 VOLTS DC**

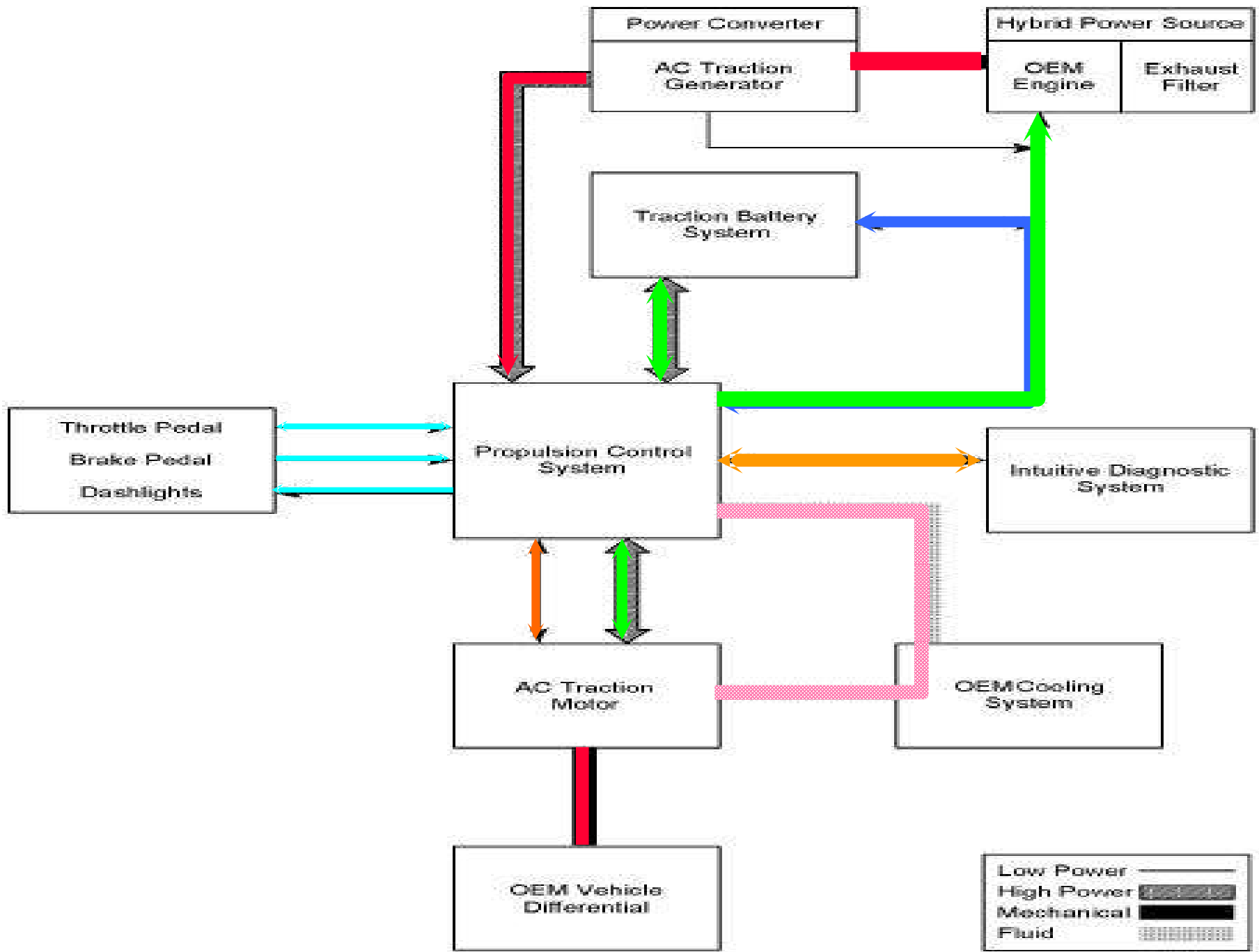



# **VI HYBRIDRIVE SAFETY**

## **HYBRIDIVE OVERVIEW**

0446

### **n AC TRACTION GENERATOR**

- 610V AC, 3 PHASE**
- ISSUE - HIGH VOLTAGE TERMINALS EXPOSED DUE TO REMOVED COVER**
- PROTECTIVE FEATURES (BATTERY CONDITIONER OFF)**
  - » COVER SECURED WITH SCREWS**
  - » TERMINALS NOT LIVE IF BUS IS OFF, AFTER 4 MIN WAITING PERIOD**





# HYBRID BUS

## DANGER ZONES

0446

### n TRACTION MOTOR

- 3 PHASE, 346 Vrms(line-line) at 500Hz
- ISSUE - HIGH VOLTAGE TERMINALS EXPOSED DUE TO REMOVED COVER
- PROTECTIVE FEATURES (BATTERY CONDITIONER OFF)
  - » COVER SECURED WITH BOLTS
  - » TERMINALS NOT LIVE IF BUS IS OFF, AFTER 4 MIN WAITING PERIOD

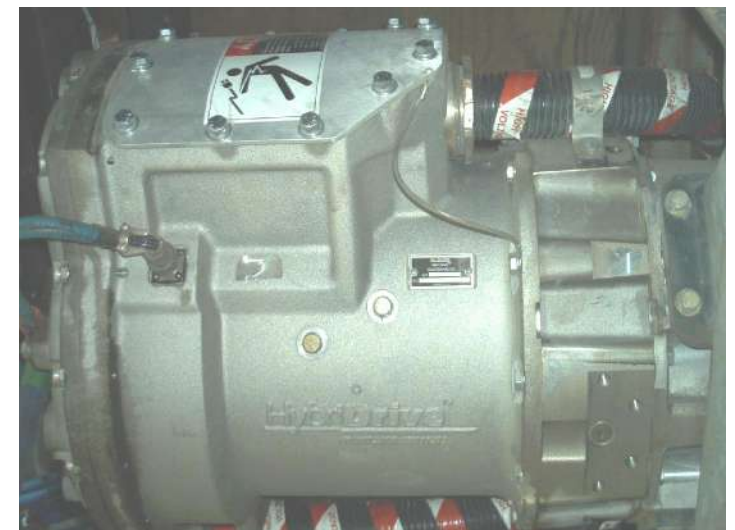



# ORIENTATION

## TRACTION BATTERY

0446

## n TRACTION BATTERY

- **HAWKER ENERGY**
  - » **MODEL XE70X**
  - » **LEAD ACID**
- **CAPACITY - 70 AMP HOUR**
- **WEIGHT 59.8 POUNDS**
- **VIRTUALLY DRY WITH NO FREE ELECTROLYTE**
  - » **NO LEAKS**
  - » **NO MAINTENANCE**

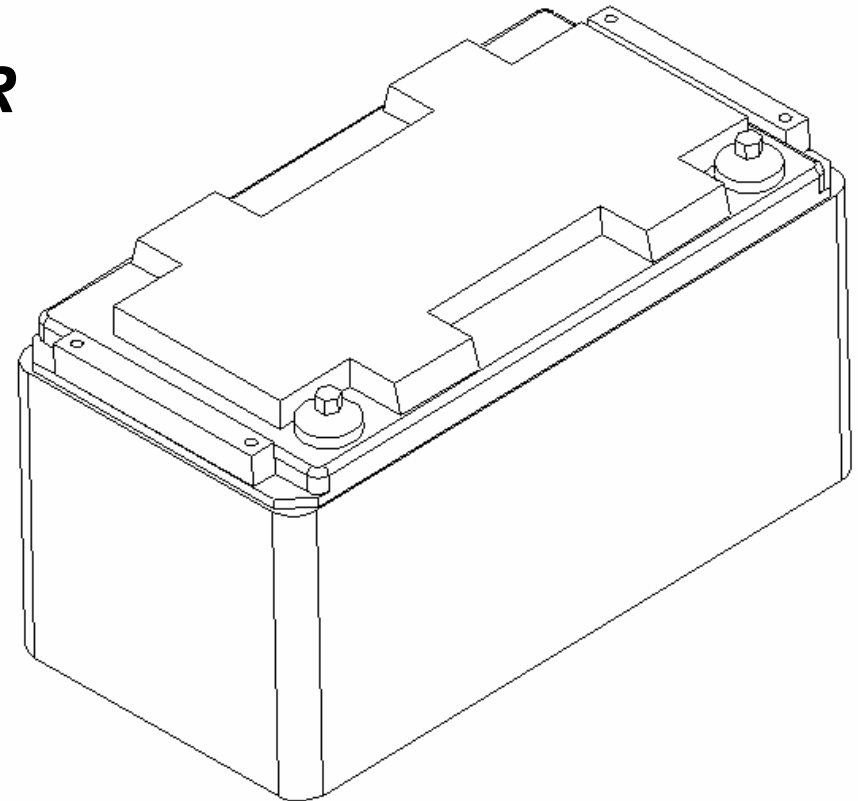

MODULE 7 PRODUCT SUPPORT CUSTOMER TRAINING

**ORION** **VII** **ORIENTATION**  
**BATTERY INSTALLATION** 0446

**n 2 ROOF MOUNTED BATTERY TUBS**

- 276V DC PER TUB
- TUBS ARE CONNECTED IN SERIES = 552 V DC
- "J" CONNECTORS-PCS TO BOSS CARD

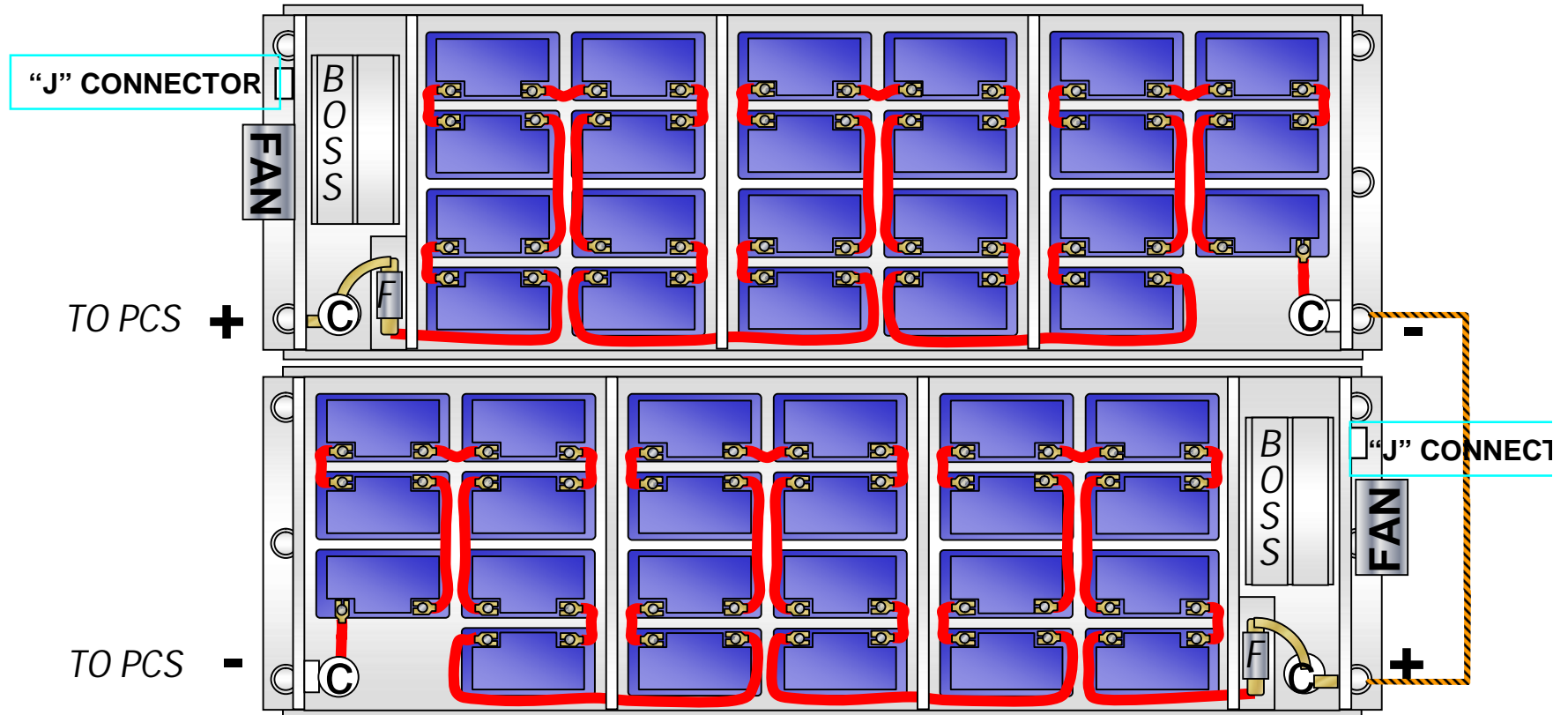



# **VI HYBRID SAFETY**

## **WARNING INDICATORS**

0446

### **n DASH HYBRIDRIVE STATUS INDICATORS**



- A SEVERE FAULT IS DETECTED IN THE HYBRIDRIVE SYSTEM**
- A DASH WARNING BUZZER WILL ALSO SOUND**
- REMOVE BUS FROM SERVICE IMMEDIATELY**



- THE HYBRIDRIVE SYSTEM IS OPERABLE IN A DEGRADED MODE AND NEEDS REPAIR**
- VEHICLE MAY BE SAFELY DRIVEN TO RETURN TO THE DEPOT FOR REPAIR**





# VII HYBRID SAFETY

## WARNING INDICATORS

0446

### n DASH HYBRIDRIVE STATUS INDICATORS

**MOTOR  
SPEED  
WARN**

- INDICATES THAT THE VEHICLE'S SPEED HAS EXCEEDED THE MAXIMUM LIMITS OF THE HYBRID PROPULSION SYSTEM
- APPLY BRAKES IMMEDIATELY TO SLOW DOWN THE BUS OR DAMAGE MAY RESULT
- THE HYBRIDRIVE SYSTEM MAY ALSO REDUCE TORQUE TO THE REAR WHEELS TO ZERO OR EVEN SHUTDOWN ALL POWER TO THE TRACTION MOTOR

**REGEN  
APPL'D**

- INDICATES ACTIVATION OF THE REGENERATIVE BRAKING OCCURING IN THE HYBRID PROPULSION SYSTEM

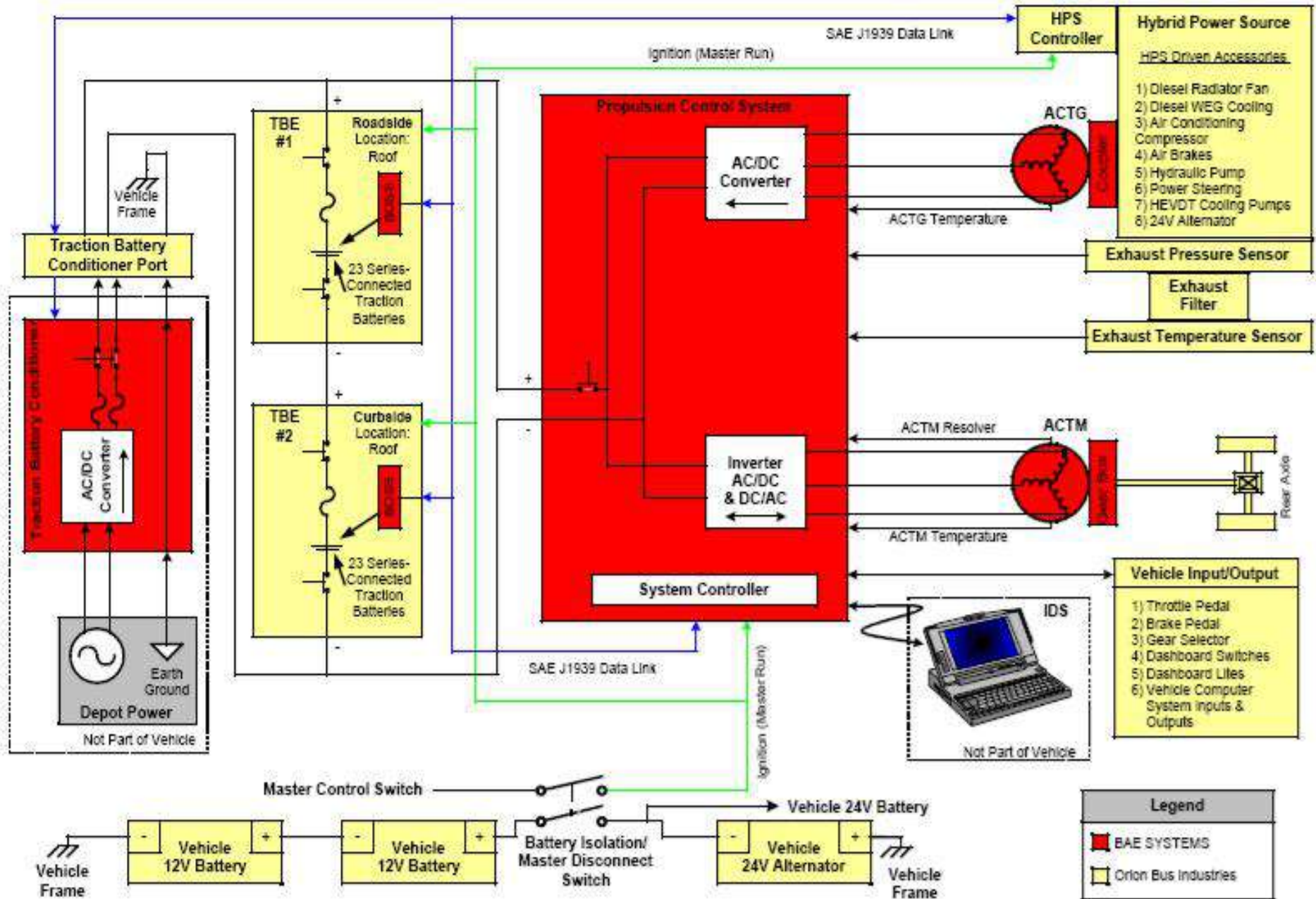



# SAFETY PROCEDURES

## WELDING PRECAUTIONS

0446

### n WHEN YOU WELD ON THE BUS

#### CAUTION

- ALWAYS CONNECT THE WELDERS GROUNDING CABLE AS CLOSE TO THE WORK AS POSSIBLE

#### CAUTION

- PLACE BATTERY ISOLATOR SWITCHES IN THE OFF POSITION

#### CAUTION

- DISCONNECT ALL SOLID STATE COMPONENTS





# SAFETY PRECAUTIONS

## WELDING DISCONNECTS

0446

**ALL MULTIPLEX  
MODULES**

**BATTERY COMPARTMENT  
BATTERY DISCONNECTS  
24V BATTERY GROUND TERM.**

**RADIO COMPARTMENT  
RADIO EQUIPMENT  
SPEAK EASY**

**DRIVER'S BARRIER  
24/12 CONVERTER  
WABCO ECU  
DOBIC**

**MAIN PANEL  
DRL MODULES**

**ENGINE COMPARTMENT  
ENGINE ECM  
VOLT. REGULATOR  
ALTERNATOR GROUND**

**REAR ELECTRICAL  
PANEL**

**24/12V CONVERTER**

**DRIVER'S COMPARTMENT  
FARE BOX  
DESTINATION SIGNS  
DUAL SPECTRUM**

MODULE 7 PRODUCT SUPPORT CUSTOMER TRAINING

**Orion** **VII ELECTRICAL WELDING DISCONNECTS** 0446

### HYBRIDRIVE DICONNECTIONS

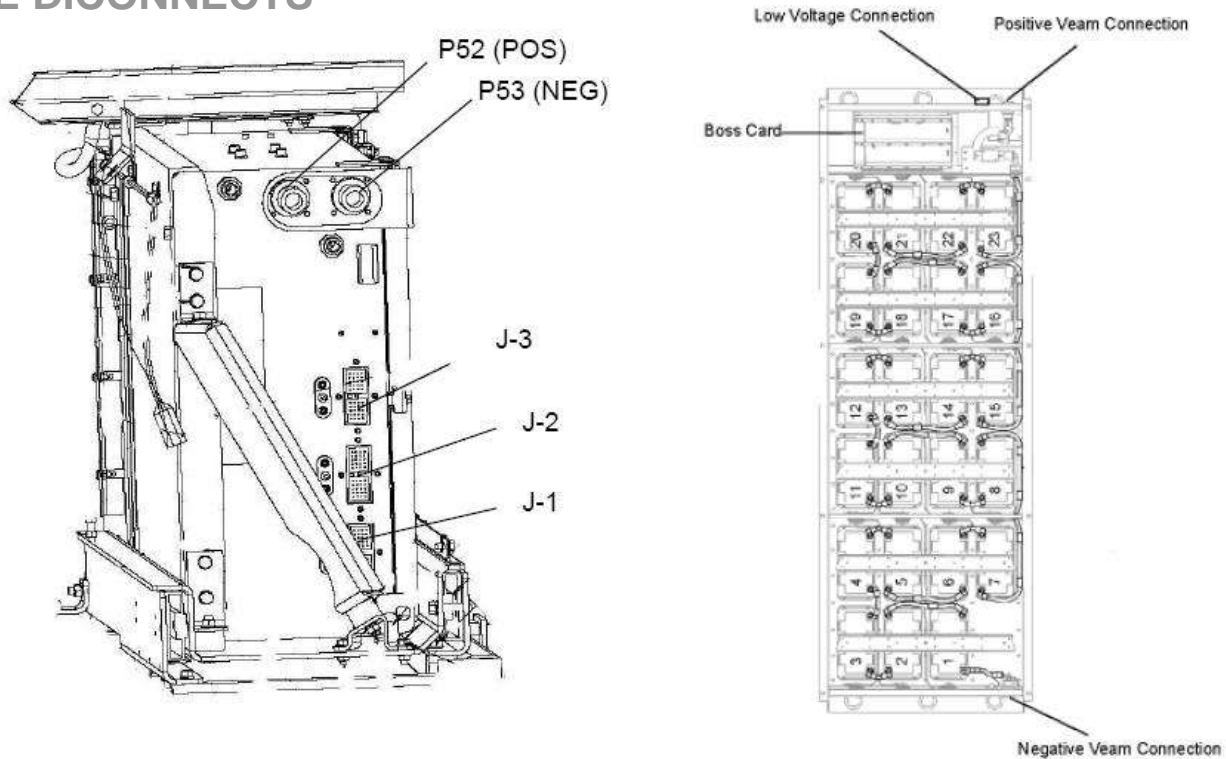

**Figure 20 Hybrid Welding Disconnections**

- **Traction battery enclosure disconnections:** low voltage connection, positive and negative veam connectors.
- **Propulsion Control System disconnections:** J1, J2, J3, P52 (POS), and P53 (NEG).



# HYBRID SAFETY

## BAE VEHICLE ACCIDENT PROCEDURES

0446

Whenever any vehicle is involved in a motor vehicle accident, the vehicle structure and subsystem components are exposed to abnormal mechanical shocks and stresses. In the instance of most minor collisions, the propulsion system components should be well protected by the structure of the vehicle.

However, in the event of any motor vehicle accident, the following steps should be taken:

- The vehicle Master Switch and 24 Vdc Battery Isolator / Master Disconnect Switch should be turned off
- All propulsion system components and enclosures should be inspected for any external signs of physical damage
- All coolant lines and connections should be inspected for signs of leaks
- After verifying that all systems appear free from physical damage, the propulsion system may be re-energized
- If any faults are detected, or if the system performs any abnormal operations, shutdown the system and place the vehicle in the service facility for further diagnostics.

In the event of a MAJOR accident, or any accident where high voltage wiring has been exposed (or is arcing), the following additional steps should be taken:

- Immediately remove all passengers from the vehicle and remove any bystanders from the vicinity of the vehicle.

Contact the appropriate Service Personnel as soon as possible for support in securing and disconnecting high voltage components. **DO NOT** cut or disconnect any exposed high voltage cables unless supervised by authorized personnel.



# HYBRID SAFETY

## HYBRID TOWING PROCEDURES

0446

### HybriDrive™ Towing Instructions

Before towing vehicles equipped with a *HybriDrive™* Propulsion System, remove both rear axles from the vehicle. Failure to comply will result in damage to the AC Traction Motor and subsequently void warranty coverage of the Traction Motor.



# **VI HYBRID SAFETY**

## **SAFETY EQUIPMENT**

0446

### **n SAFETY EQUIPMENT**

- USE PERSONAL PROTECTIVE EQUIPMENT AS A LAST LINE OF DEFENSE IN CASE SOMETHING GOES WRONG**
- AVOID FALSE SENSE OF SECURITY GRANTED BY USE OF PROTECTIVE EQUIPMENT**
- AVOID DETERMINING IF THE EQUIPMENT WORKS AS ADVERTISED**

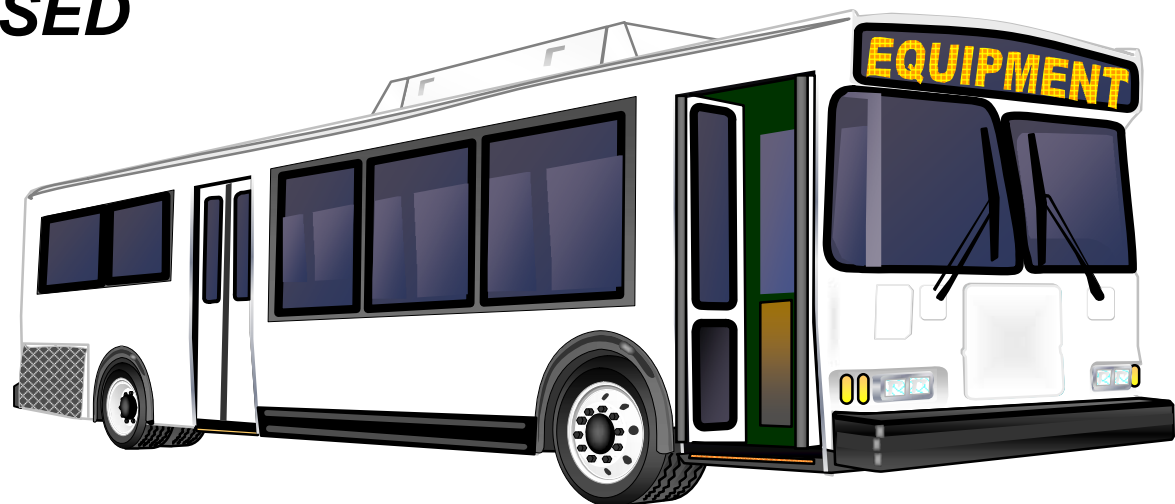





# **VII HYBRID SAFETY**

## **SAFETY EQUIPMENT**

0446

### **n HIGH VOLTAGE GLOVES SLEEVES, & APRON**

- MUST BE RATED AT CLASS 0 (1000V DC) MINIMUM**
- SHOULD BE WORN WHILE REMOVING INNER LID**
- MUST BE WORN AT ALL TIMES WHILE INNER TUB LID IS REMOVED**

### **n SLEEVES, & APRON (WORN FOR BENCH WORK)**



## **n TERMINAL INSULATOR**

- LOOSE CABLE ENDS CAN CONTACT THE TUB CHASSIS CREATING A SHORT CIRCUIT OR ELECTROCUTION HAZARD**
- ALWAYS COVER LOOSE CABLE ENDS WITH TERMINAL INSULATORS**

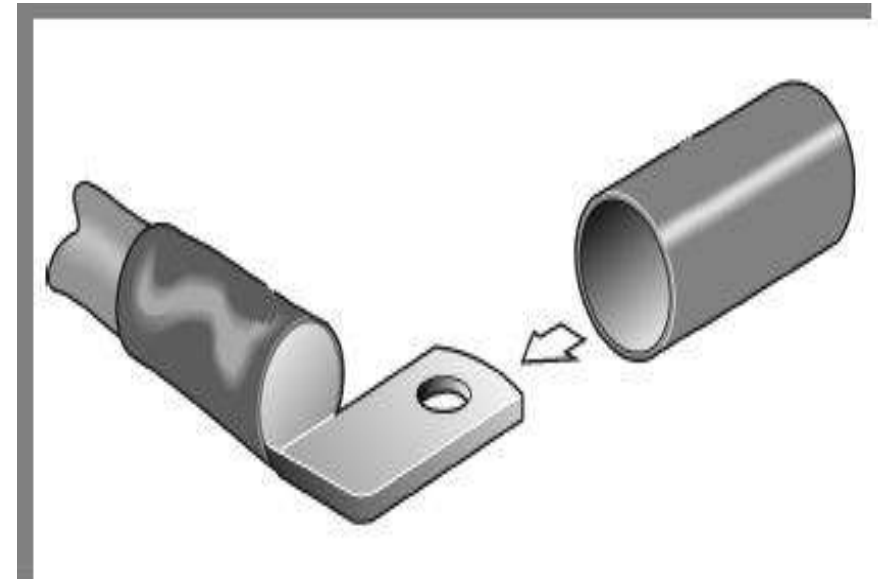
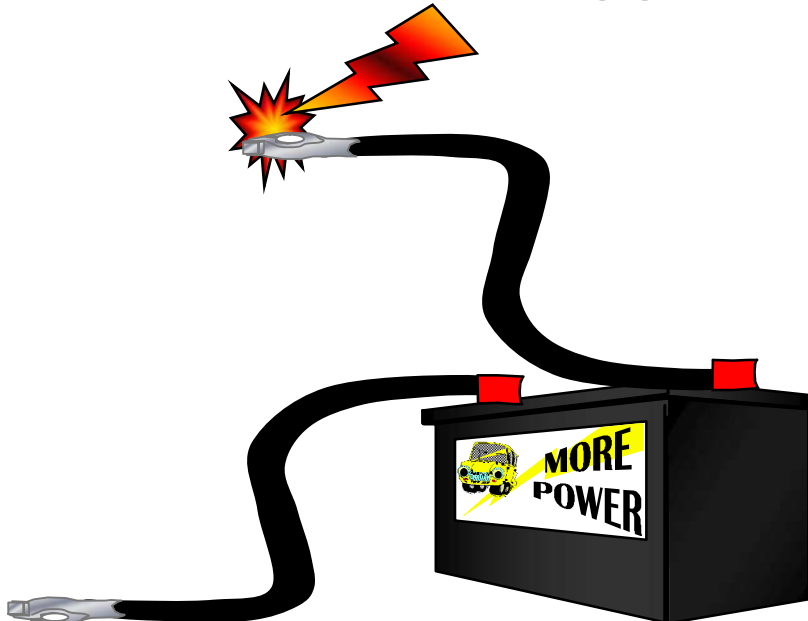

Orion **MODULE 7 PRODUCT SUPPORT CUSTOMER TRAINING**  
**VII HYBRID SAFETY**  
**SAFETY EQUIPMENT** 0446

## **n INSULATED THROW POLE - SAFETY HARNESS**

- ALWAYS USE THE BUDDY SYSTEM WHILE SERVICING THE BATTERY TUB - CONSIDER IT A “NO LONE ZONE”**
- IN CASE OF AN ACCIDENT, THIS POLE AND / OR A SAFETY HARNESS AND LANYARD MAY BE USED TO PULL PERSONNEL AWAY FROM THE HIGH VOLTAGE AREA, WHILE ISOLATING THE “BUDDY” FROM THE HIGH VOLTAGE HAZARD**

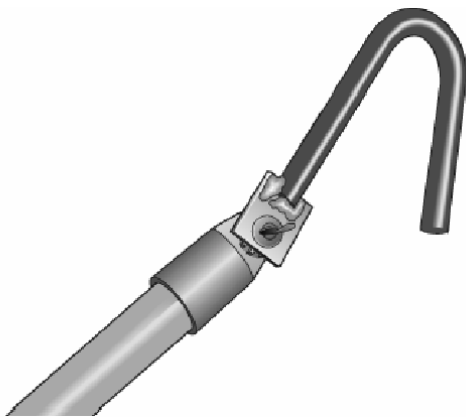



# **VI BATTERY ENCLOSURE SAFETY**

0446

## **n ELECTRICAL INSULATOR BLANKETS**

- CLEAR, NON-CONDUCTIVE RUBBER SHEETS**
- PREVENTS INADVERTENT CONTACT WITH HIGH VOLTAGE COMPONENTS**
- USE HALF-SIZED SHEETS TO COVER COMPARTMENT BEING WORKED ON**

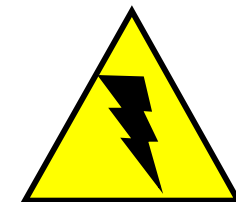
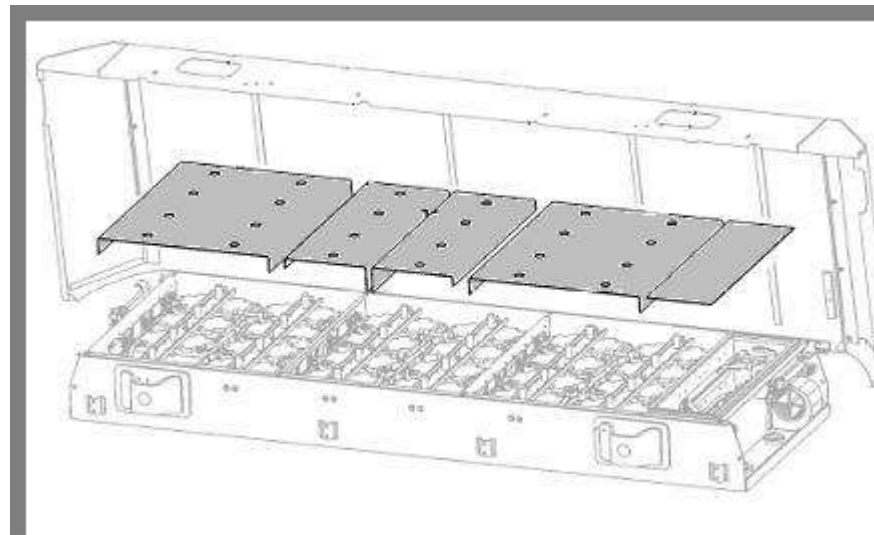

MODULE 7 PRODUCT SUPPORT CUSTOMER TRAINING



**VII BATTERY ENCLOSURE**

**SAFETY**

0446

## **n PLYWOOD WORKING PLATFORMS**

- PROVIDES A SURFACE TO WORK ON WHILE SERVICING BATTERY TUB**
- MUST BE USED OVERTOP OF INSULATOR BLANKETS**
- USE HALF SIZED PLATFORM IF NECESSARY OVER COMPARTMENT BEING WORKED ON**

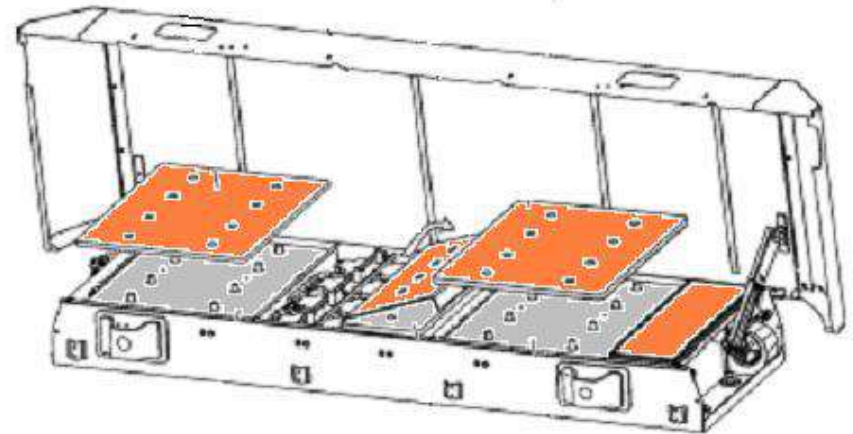
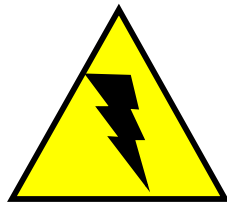



# **VI HYBRID SAFETY**

## **SAFETY EQUIPMENT**

0446

### **n PLYWOOD WORKING PLATFORMS**

- PROVIDES A SURFACE TO WORK ON WHILE SERVICING BATTERY TUB**
- MUST BE USED OVERTOP OF INSULATOR BLANKETS**
- USE HALF SIZED PLATFORM IF NECESSARY OVER COMPARTMENT BEING WORKED ON**

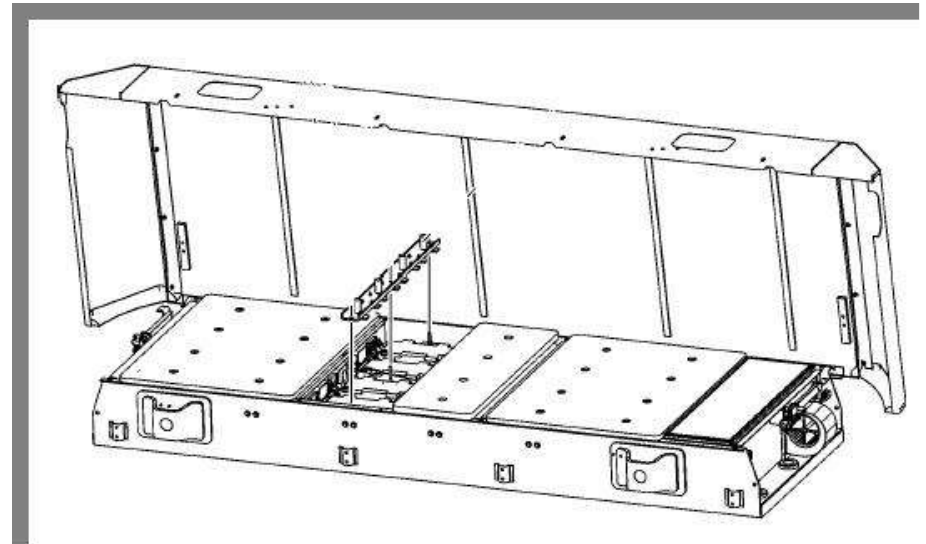



# **VI HYBRID SAFETY**

## **SAFETY EQUIPMENT**

0446

### **n WORKING PLATFORM**

- ALLOWS WORKERS TO ACCESS TUBS FROM THE SIDE OF THE BUS**
- SHOULD BE 115" HIGH TO PROVIDE A GOOD WORKING LEVEL AT ROOF HEIGHT**
- SHOULD BE 160" LONG TO GIVE ACCESS TO BOTH ENDS OF THE TUB**

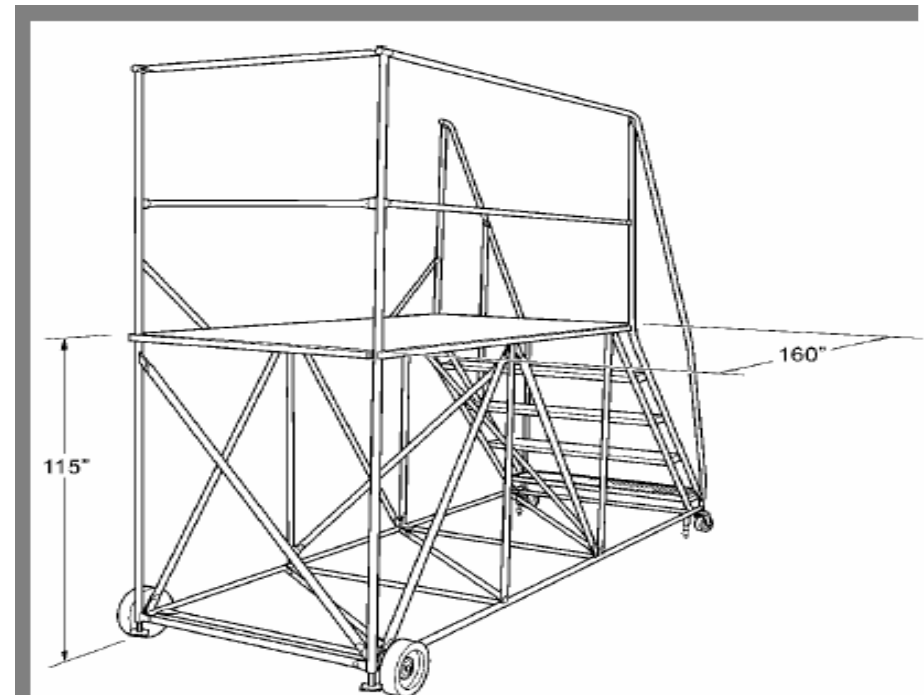



# **VI HYBRID SAFETY**

## **SAFETY EQUIPMENT**

0446

### **n ADDITIONAL SAFETY EQUIPMENT**

- INSULATED WRENCHES AND TOOLS FOR WORKING WITHIN BATTERY ENCLOSURE (1000 V, CLASS 0 MIN)**
- FIRE EXTINGUISHER (DRY CHEMICAL)**
- SAFETY GLASSES OR FACE SHIELD**
- DIGITAL VOLTAGE METER AND TEST PROBES RATED FOR 1000V DC (USED TO CHECK FOR GROUND FAULTS)**

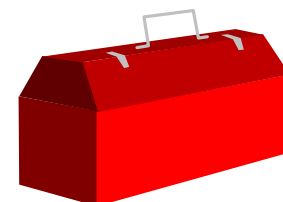
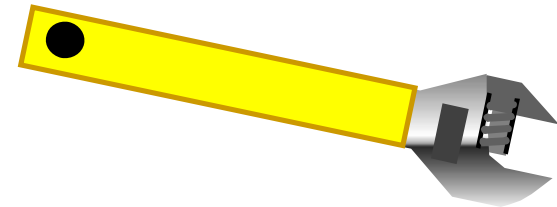





## **VII HYBRID SAFETY**

### **GENERAL SAFETY PRECAUTIONS**

0446

## **n PRECAUTIONS**

- ALWAYS REFER TO THE SERVICE MANUAL BEFORE ATTEMPTING TO SERVICE TUBS**
- INSULATED TOOLS AND EQUIPMENT MUST BE INSPECTED FOR DAMAGE OR WEAR PRIOR TO USE**
- DO NOT ATTEMPT TO SERVICE THE BATTERY TUBS WHEN THE TRACTION BATTERY CONDITIONER IS CONNECTED**
- WHEN WORKING ON THE ROOF OF THE BUS WEAR A SAFETY HARNESS**



# **VI HYBRID SAFETY**

## **GENERAL SAFETY PRECAUTIONS**

0446

### **n PRECAUTIONS (CONT'D)**

- REMOVE ALL METAL OBJECTS FROM YOUR BODY THAT COULD MAKE CONTACT WITH THE COMPONENTS IN THE TUB - FALLING OBJECTS SUCH AS PENS AND METAL GLASSES CAN CREATE SHORT CIRCUITS BETWEEN THE BATTERY TERMINALS OR OTHER COMPONENTS**
- ALWAYS CHECK FOR A GROUND FAULT WITHIN THE BATTERY TUB BEFORE YOU BEGIN WORKING ON IT - REFER TO THE SERVICE MANUAL FOR INSTRUCTIONS**





## **VI HYBRID SAFETY**

### **GENERAL SAFETY PRECAUTIONS**

0446

#### **n PRECAUTIONS (CONT'D)**

- ALL WIRING IN THE BATTERY TUB CARRIES A HIGH VOLTAGE, THIS INCLUDES THE SMALL SIGNAL WIRING TO THE BOSS AND EQUALIZATION CARDS- NEVER TOUCH ANY WIRES OR COMPONENTS IN THE TUB WITH YOUR BARE HANDS !**
- USE CAUTION WHEN TOUCHING ANY WIRE ENDS ON ANY OF THE HARNESSSES IN THE TUB - FRAYED WIRE ENDS CAN PIERCE RUBBER GLOVES AND ENTER YOUR SKIN**



# **VI HYBRID SAFETY**

## **GENERAL SAFETY PRECAUTIONS**

0446

### **n PRECAUTIONS (CONT'D)**

- DON'T ATTEMPT REPAIR WORK WHEN YOU ARE OVER TIRED OR SICK - NOT ONLY WILL YOU BE MORE CARELESS, BUT YOUR PRIMARY DIAGNOSTIC TOOL - DEDUCTIVE REASONING - WILL NOT BE OPERATING AT FULL CAPACITY**
- FINALLY, NEVER ASSUME ANYTHING WITHOUT CHECKING IT OUT FOR YOURSELF! DON'T TAKE SHORTCUTS!**

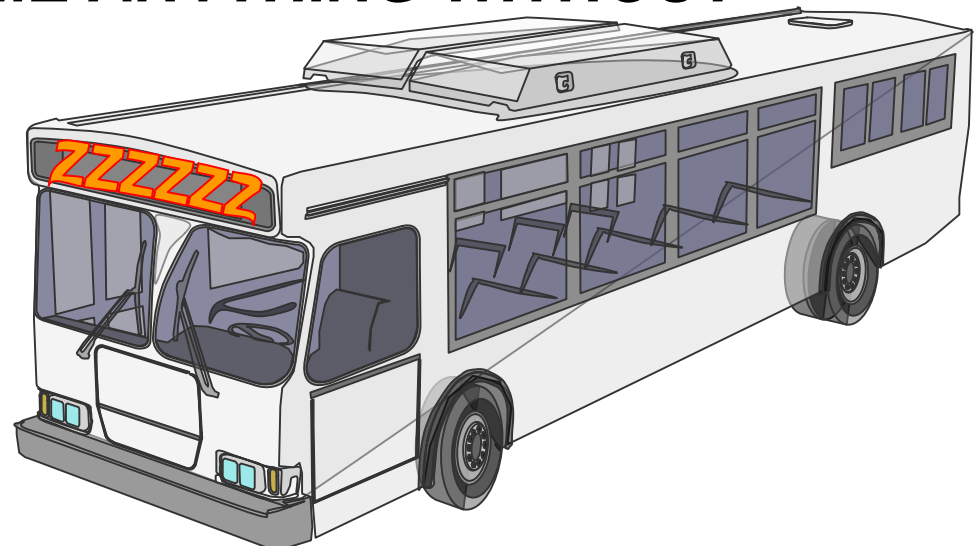



# **VII HYBRID SAFETY**

## **MASTER DISCONNECT SWITCH**

0446

### **n MASTER DISCONNECT SWITCH**

- CUTS POWER TO ALL HYBRID SYSTEM ELECTRONICS**
- DIRECTLY POWERS BATTERY TUB CONTACTORS**
- WAIT 4 MINUTES AFTER SWITCHING THIS SWITCH BEFORE DISCONNECTING ANY HIGH VOLTAGE CONNECTORS**

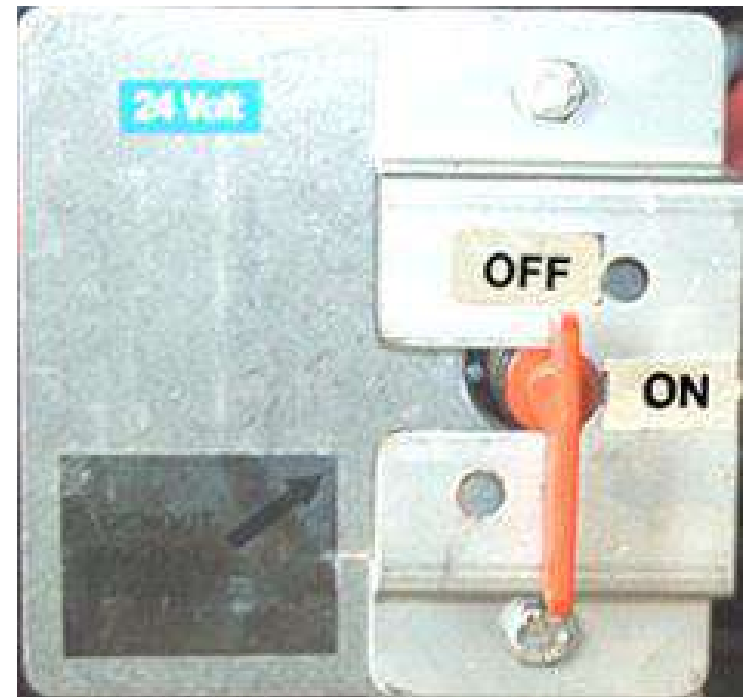



# VII HYBRID SAFETY

## BATTERY ISOLATION

0446

### n WORK SAFE

- **USE OF BATTERY ISOLATOR SWITCH IS MANDATORY WHEN PERFORMING MAINTENANCE ON HYBRID SYSTEM**
  - » **MEASURE BEFORE TOUCHING**



MODULE 7 PRODUCT SUPPORT CUSTOMER TRAINING

**ORION** **VII** **BATTERY ENCLOSURE**  
**ELECTRICAL LAYOUT** 0446

# BASIC LAYOUT OF COMPONENTS

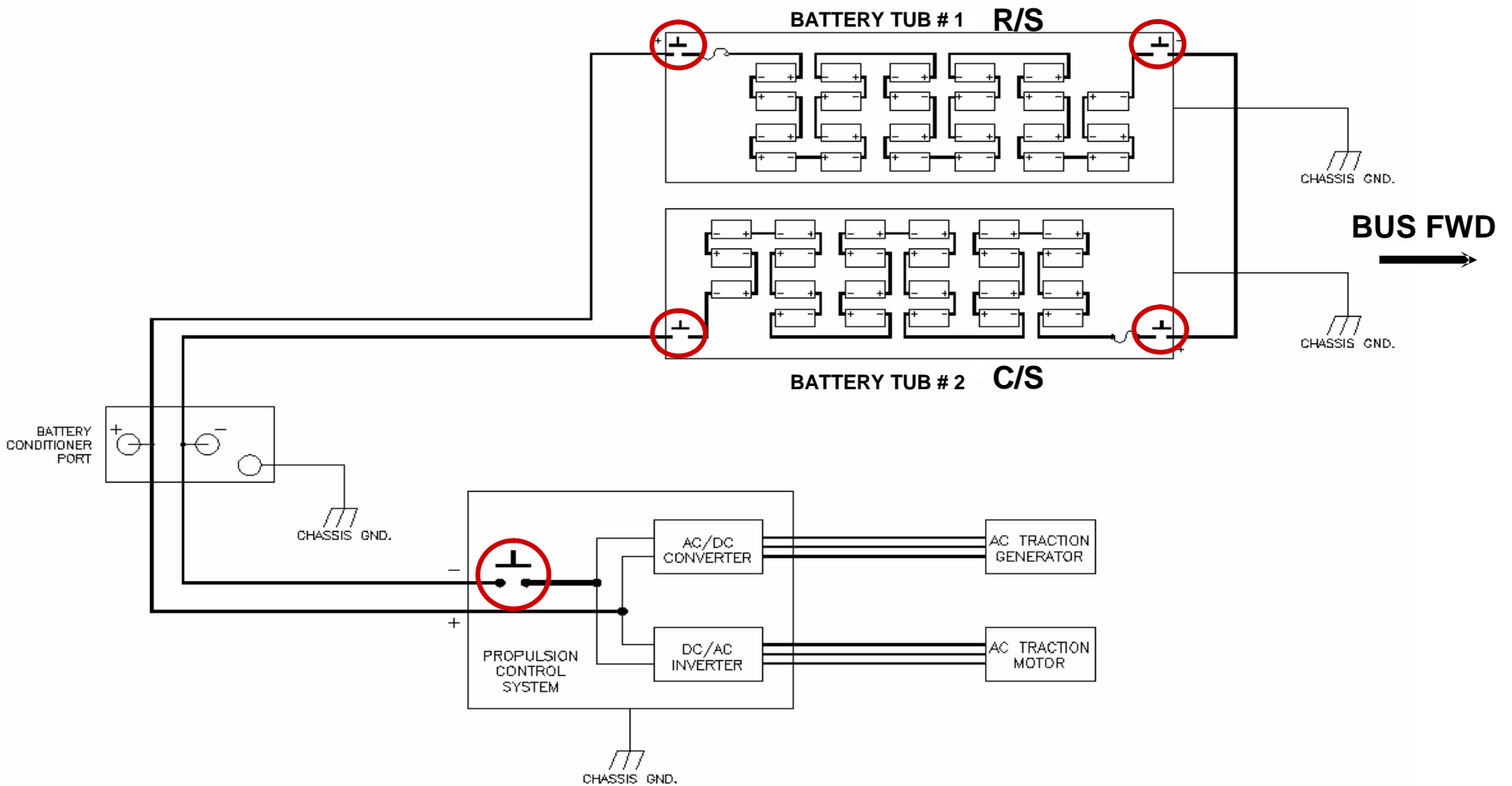

ORION **MODULE 7 PRODUCT SUPPORT CUSTOMER TRAINING**  
**VII HYBRID SAFETY**  
**AC TRACTION GENERATOR** 0446

## **n BATTERY TUB VEAM CONNECTOR**

- CUTS POWER BETWEEN BATTERY TUBS & BUS**
- DISCONNECTING THE VEAM CONNECTORS DOES NOT MAKE IT SAFE TO WORK INSIDE THE BATTERY TUBS**

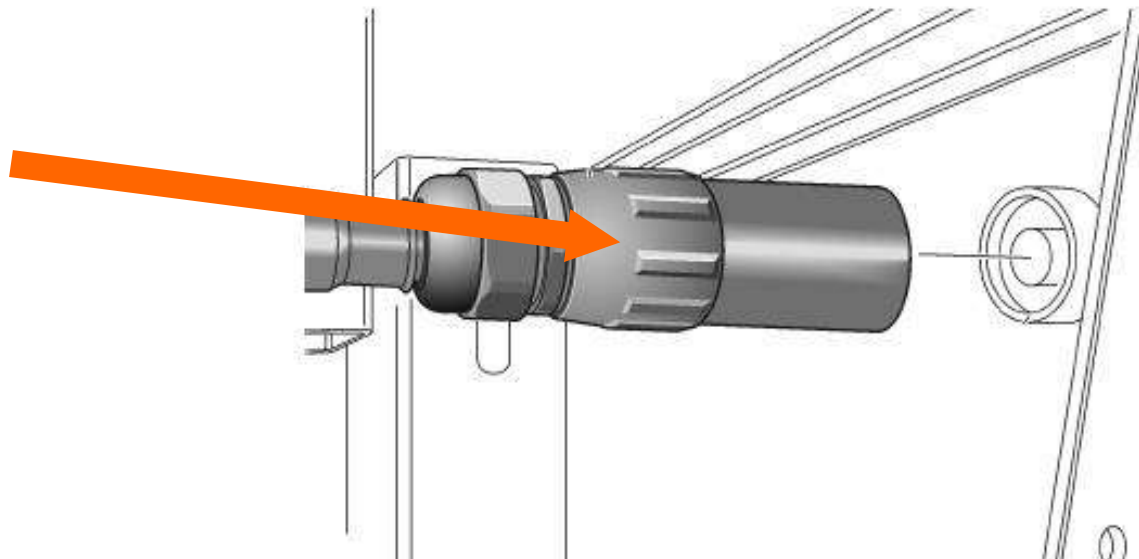



MODULE 7 PRODUCT SUPPORT CUSTOMER TRAINING



**VI HYBRID SAFETY**

**VEAM CONNECTOR**

0446

## n **VEAM CONNECTORS**

- **FINGERPROOFED CONNECTORS**
  - » **LOCKING PIN**
- **BETWEEN BATTERY ENCLOSURES AND PCS**
- **NEVER DISCONNECT WHILE BUS IS RUNNING**

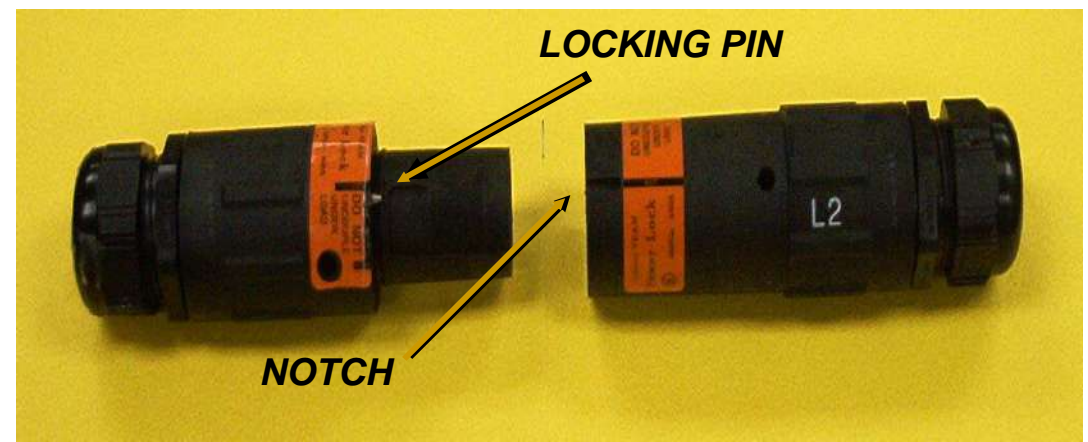

MODULE 7 PRODUCT SUPPORT CUSTOMER TRAINING

**Orion** **VII HYBRID BUS**

**DANGER ZONES** 0446

## n PROPULSION CONTROL SYSTEM - PCS

- **NEVER DISCONNECT VEAM CONNECTORS WHILE BUS IS RUNNING OR MASTER DISCONNECT IS ENGAGED**
- **YOU COULD BE SERIOUSLY OR FATALLY INJURED BY ELECTRICAL SHOCK IF YOU ATTEMPT TO OPEN, DISCONNECT, REPAIR, TEST, INSPECT, OR ADJUST**
- **PROTECTIVE FEATURES (BATTERY CONDITIONER OFF)**
  - » **VEAM CONNECTORS**
  - » **CONNECTORS NOT LIVE IF BUS IS OFF, AFTER 4 MIN WAITING PERIOD**

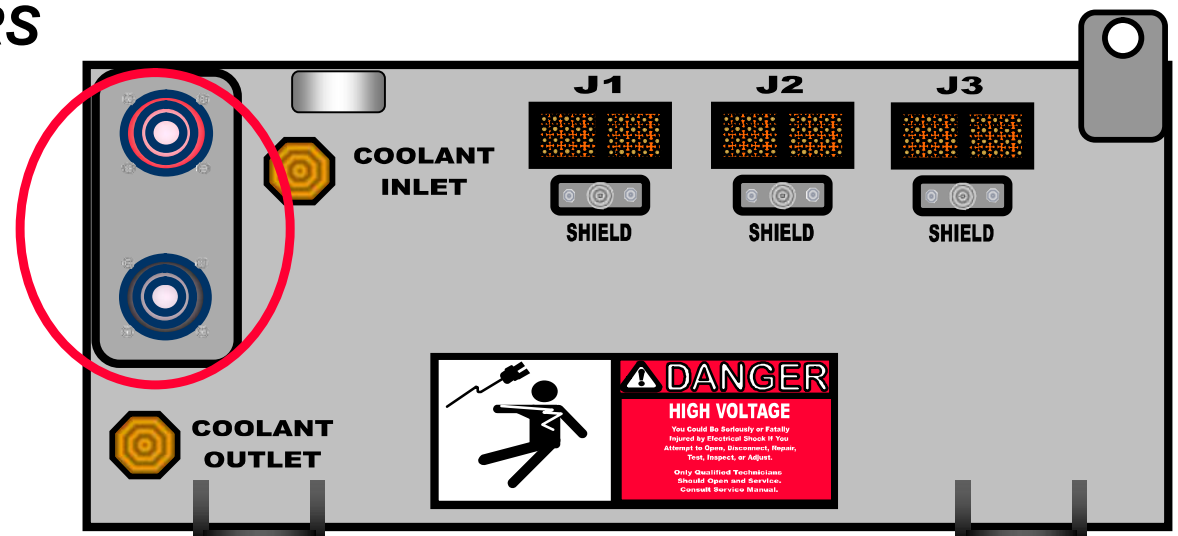



# **VI HYBRIDRIVE SAFETY**

## **DANGER ZONES**

0446

### **n AC TRACTION GENERATOR**

- VERIFY CIRCUIT IS DE-ENERGIZED, < 5 VDC**
  - » PHASE TO CHASSIS**
  - » PHASE TO PHASE**
- ISSUE - HIGH VOLTAGE TERMINALS EXPOSED DUE TO REMOVED COVER**
- PROTECTIVE FEATURES (BATTERY CONDITIONER OFF)**
  - » COVER SECURED WITH SCREWS**
  - » TERMINALS NOT LIVE IF BUS IS OFF, AFTER 4 MIN WAITING PERIOD**





## HYBRID BUS

### DANGER ZONES

0446

## n TRACTION MOTOR

- **VERIFY CIRCUIT IS DE-ENERGIZED, < 5 VDC**
  - » **PHASE TO CHASSIS**
  - » **PHASE TO PHASE**
- **ISSUE - HIGH VOLTAGE TERMINALS EXPOSED DUE TO REMOVED COVER**
- **PROTECTIVE FEATURES (BATTERY CONDITIONER OFF)**
  - » **COVER SECURED WITH BOLTS**
  - » **TERMINALS NOT LIVE IF BUS IS OFF, AFTER 4 MIN WAITING PERIOD**





# VII HYBRID BUS

## DANGER ZONES

0446

### n TRACTION BATTERY CHARGER

- ISSUE - HIGH VOLTAGE TERMINALS - CONNECTED DIRECTLY TO BATTERY TUBS
- PROTECTIVE FEATURES
  - » CONNECTORS NOT LIVE IF BUS IS OFF, MASTER DISCONNECT OFF





# **VII HYBRID SAFETY**

## **DANGER ZONES**

0446

### **n TRACTION BATTERY SYSTEM (BATTERY ENCLOSURE)**

- NOT DE-ENERGIZED BY BATTERY ISOLATOR SWITCH-ENERGIZED WHETHER THE BUS IS RUNNING OR NOT**
- CHARGING VOLTAGE IS 350 VDC PER ENCLOSURE**
- BATTERY VOLTAGE PER ENCLOSURE IS 276 VDC**
- CONTACTORS IN EACH ENCLOSURE**
  - » ONE EACH FOR NEGATIVE AND POSITIVE CONNECTIONS**



MODULE 7 PRODUCT SUPPORT CUSTOMER TRAINING

**Orion** **VI HYBRID SAFETY**

**BATTERY TUB** 0446

**n HIGH VOLTAGE (276 VOLTS PER TUB)**

- DEVELOPED AS THE RESULT OF CONNECTING TWENTY-THREE 12VDC BATTERIES IN SERIES
- WHEN CONNECTED, HIGH VOLTAGE POTENTIAL EXISTS ON ANY BATTERY OR LEAD IN THE TUB
- CHECK FOR GROUND FAULTS

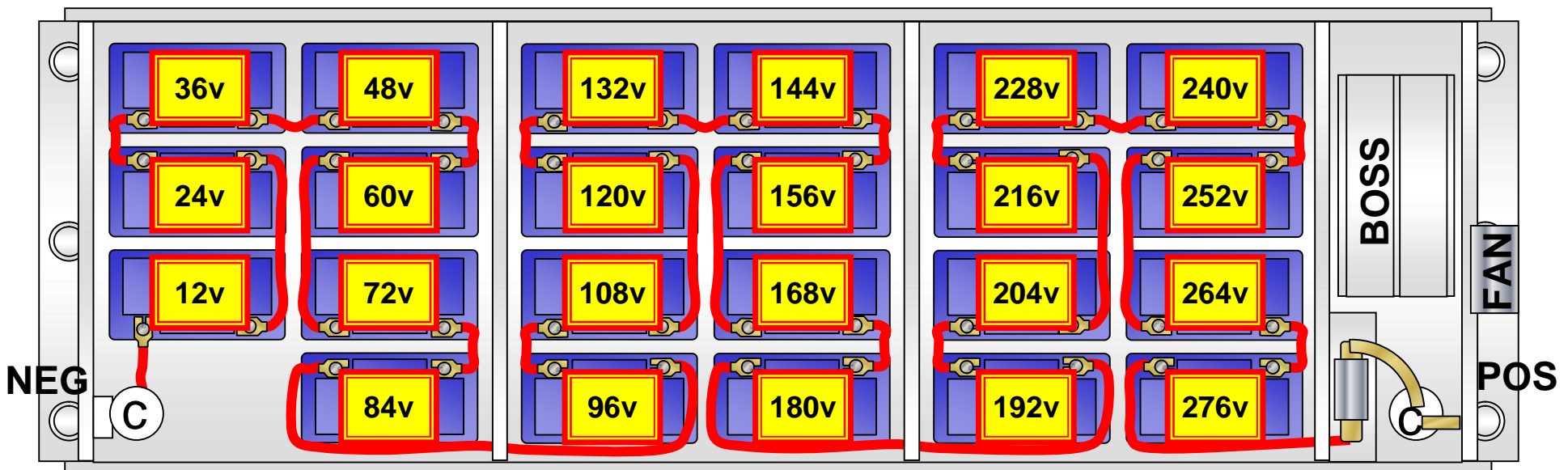

MODULE 7 PRODUCT SUPPORT CUSTOMER TRAINING

**Orion** **VI HYBRID SAFETY**

**BATTERY TUB** 0446

## n HIGH VOLTAGE (276 VOLTS PER TUB)

– LIMITED VOLTAGE WHEN BATTERIES ARE ISOLATED - IE.

- » BATT.#1 TO GROUND CONTACTOR= 12VDC
- » BATT.#5 TO GROUND CONTACTOR= 60VDC
- » BATT.#23 TO GROUND CONTACTOR =276VDC
- » BATT.#20 TO BATT.# 23= 48VDC

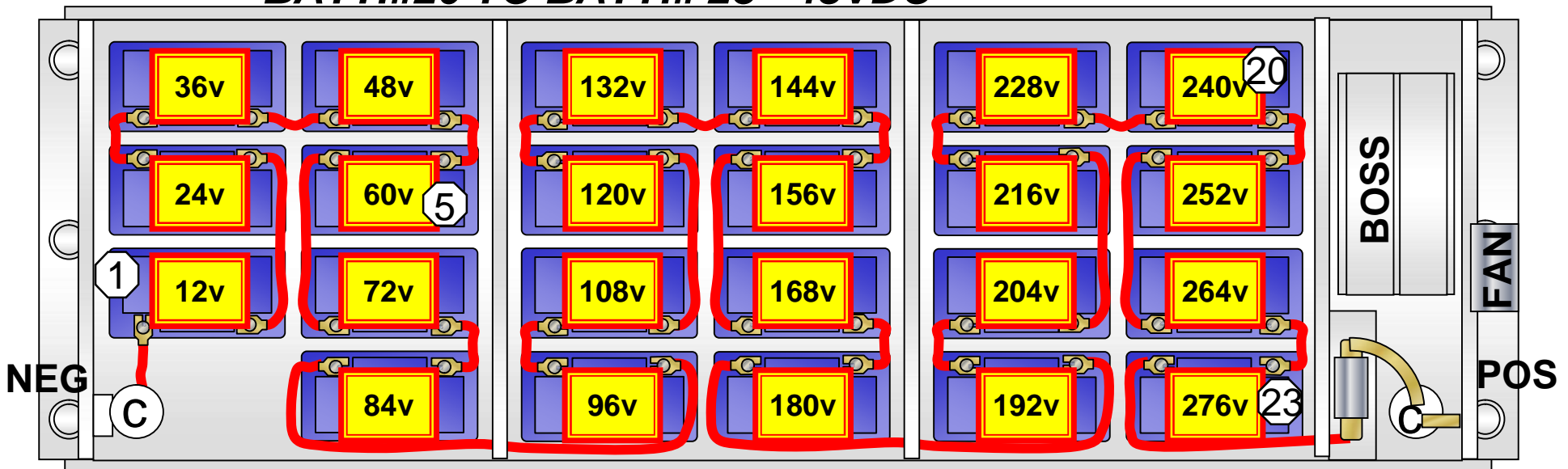



MODULE 7 PRODUCT SUPPORT CUSTOMER TRAINING

**Orion** **VII HYBRID SAFETY**

**BATTERY TUB** 0446

**n NO LONE ZONE - HIGH VOLTAGE**

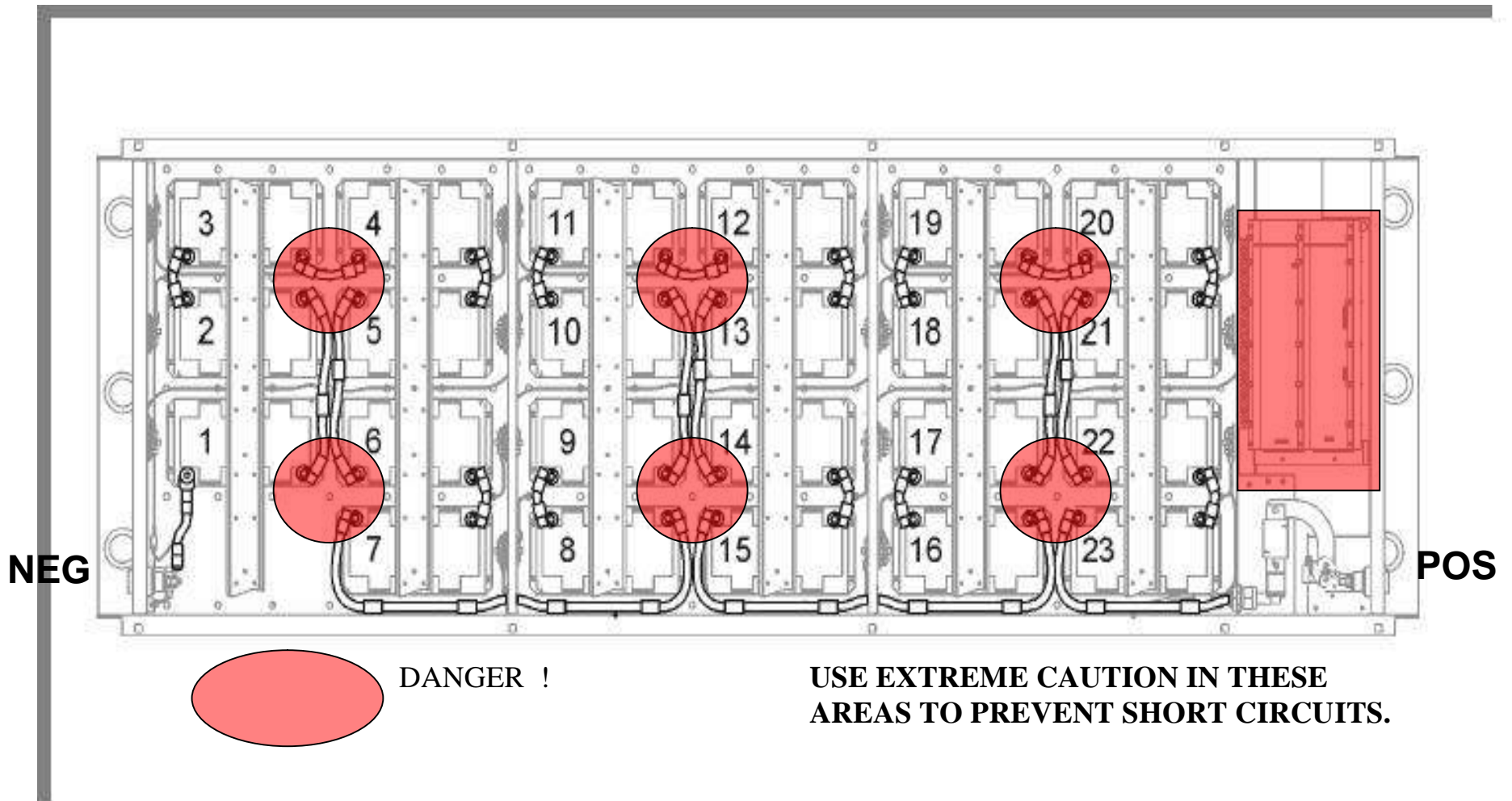

MODULE 7 PRODUCT SUPPORT CUSTOMER TRAINING

**Orion** **VII HYBRID SAFETY**

**BATTERY INSTALLATION** 0446

**n BATTERY TUB BUILD-UP**

- CONNECT BATTERY AS PER NUMBERED SEQUENCE, TORQUE TO 60 IN LBS**
- CONNECT FLYING LEADS IN CORRECT SEQUENCE**

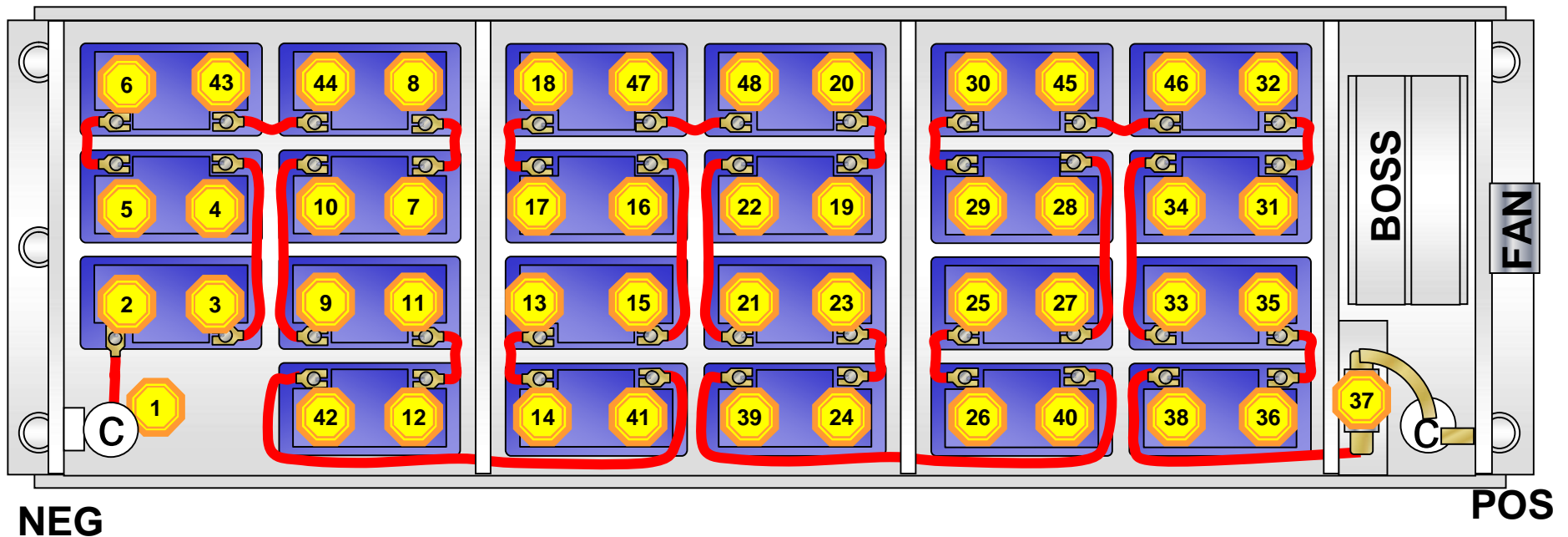



**n CHECK FOR GROUND FAULTS**

- BATTERY TUB(S) TO GROUND**
- PCS TO ACTM 3 PHASE TO GROUND**
- PCS TO ACTG 3 PHASE TO GROUND**

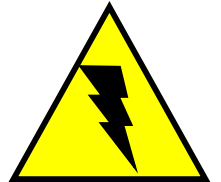

**n STOP HEV INDICATOR AND BUS SHUTDOWN WITH NO OVERRIDE WHEN THE PCS DETECTS A GROUND FAULT**

- IDS WILL INDICATE A CODE A043 OR A045 WHEN THIS OCCURS**
  - » USE OF BOTH BAE'S AND ORION SERVICE MANUALS MAY BE REQUIRED TO IDENTIFY AND REPAIR THE GROUND FAULT**

ORION **MODULE 7 PRODUCT SUPPORT CUSTOMER TRAINING**  
**BATTERY ENCLOSURE MAINT** 0446

**n CHECK FOR GROUND FAULTS, < 1 VOLT**

- BATTERY #23 **POSITIVE** TERMINAL TO CHASSIS
- BATTERY #1 **NEGATIVE** TERMINAL TO CHASSIS
- IF THIS TEST FAILS -TROUBLESHOOT AND REPAIR THE GROUND FAULT BEFORE PROCEEDING

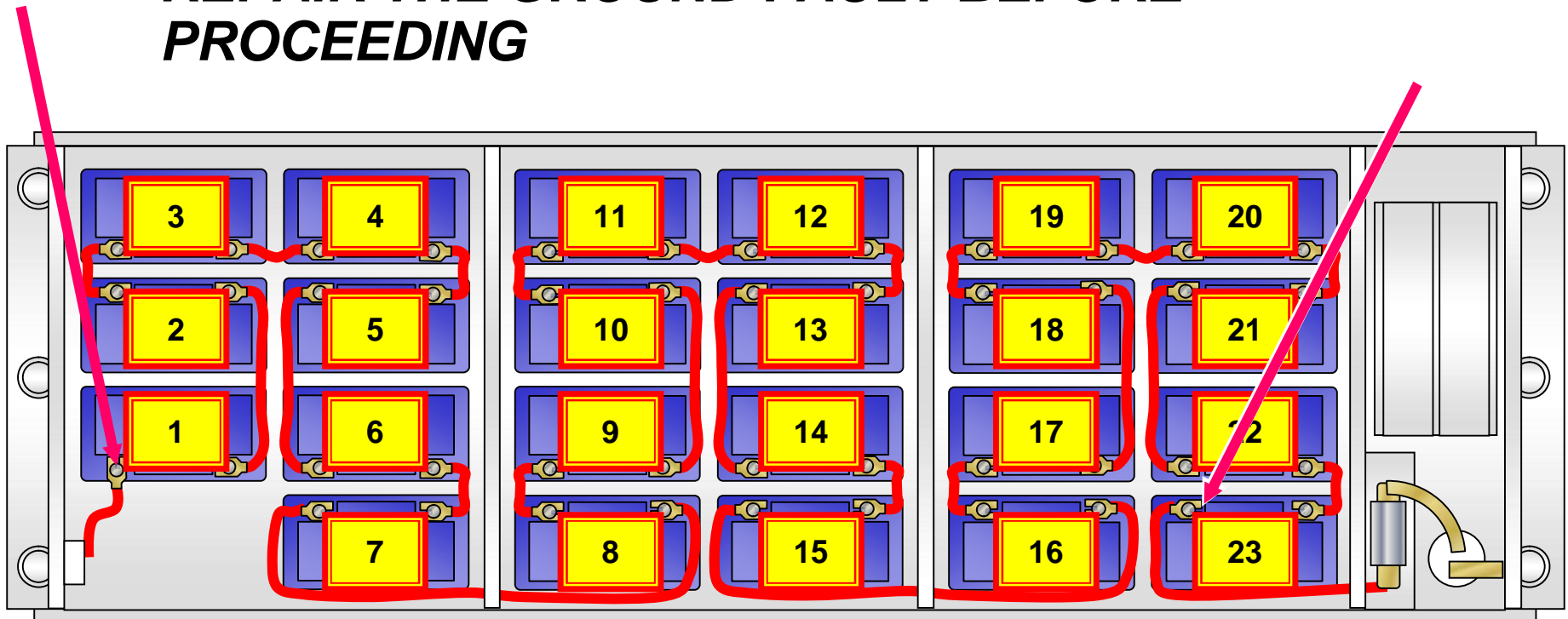
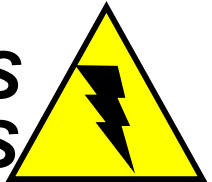



# **VII HYBRID SAFETY**

## **SAFETY PRACTICES**

0446

### **n WORK SAFE**

- ALLOW 4 MINUTES TO DISCHARGE CONTACTORS**
  - » TWO PER BATTERY ENCLOSURE**
  - » ONE IN PCS**
- WORKING WITHIN BATTERY ENCLOSURE WHILE ON THE ROOF**
  - » EXTREME VOLTAGES ARE EXPOSED**
  - » CARE WITH TOOLS & HARDWARE**
- MEASURE BEFORE TOUCHING**
- DURING BATTERY CONDITIONING**
  - » TREAT SYSTEM AS ENGINE RUNNING**





# HYBRID SAFETY

## SAFETY PRACTICES

0446

### **n WORK SAFE (CONT'D)**

- INSTALL SAFETY PINS IN PRIMARY COVER**
- USE TWO PEOPLE TO REMOVE BATTERY TUB INTERIOR COVER**
- DISCONNECT VEAM CONNECTORS AT TUBS TO FURTHER ISOLATE BATTERY TUBS**
- CHECK FOR GROUND FAULTS**
- USE DIELECTRIC COVERS/PLATFORMS WHEN WORKING INSIDE THE BATTERY TUBS**
- WEAR GLOVES AND FACE SHIELD**
- ESTABLISH PERSON REMOVAL PROCEDURE**



MODULE 7 PRODUCT SUPPORT CUSTOMER TRAINING

**Orion** **VII** **HYBRID SAFETY**

**CONCLUSION** **0446**

**REMEMBER, HIGH VOLTAGE IS ALWAYS ON THE ROOF**

**HIGH VOLTAGE AT THE MOTOR, GENERATOR, AND PCS WHEN ENGINE IS RUNNING**

**MEASURE BEFORE YOU TOUCH**

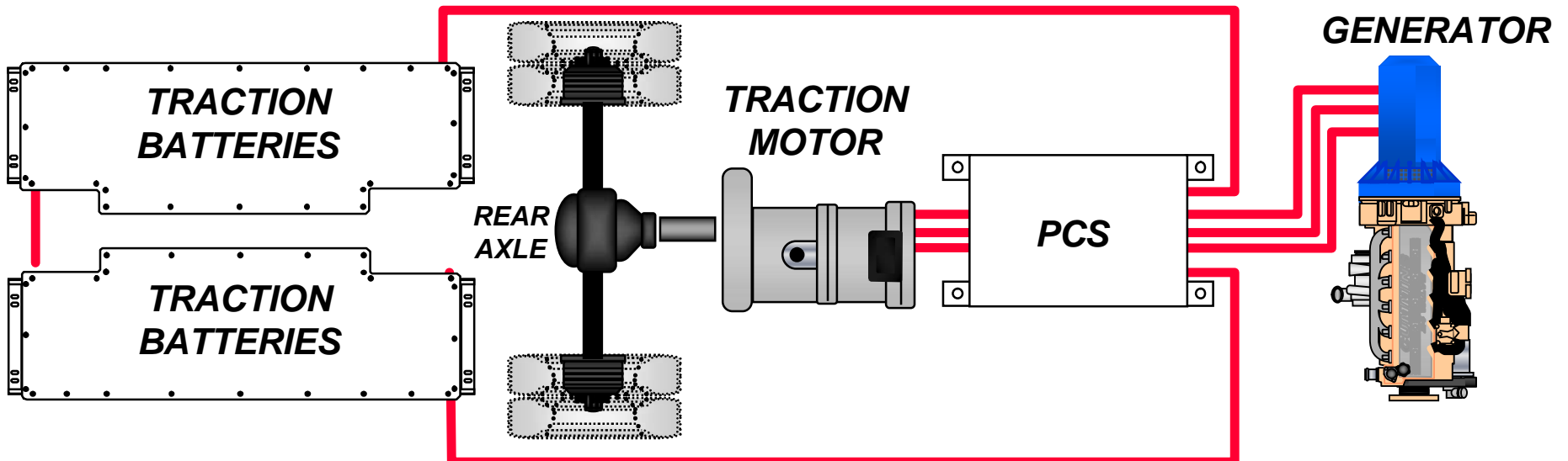

MODULE 7 PRODUCT SUPPORT CUSTOMER TRAINING



**VII HYBRID SAFETY**

**SAFETY PRACTICES**

0446

## n PART NUMBERS - ORION VII

- 070775123      **INSULATOR-TERMINAL**
- 070775124      **INSULATOR-BAT TUB SVC.1**
- 070775125      **INSULATOR-BAT TUB SVC.2**
- 070775126      **INSULATOR-BAT.TUB SVC.3**
- 070775128      **TOOL-BAT.TUB.WRK.PLTFRM**
- 070775172      **TOOL.BATTERY WRK.PLTFRM**

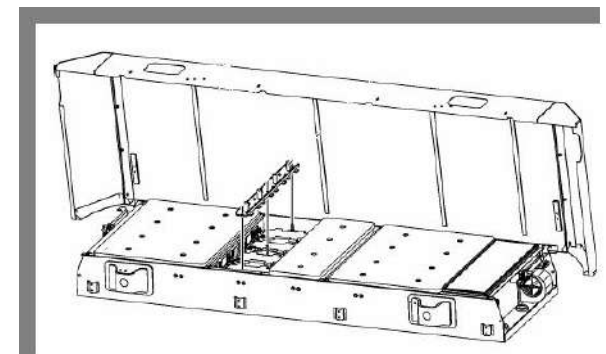
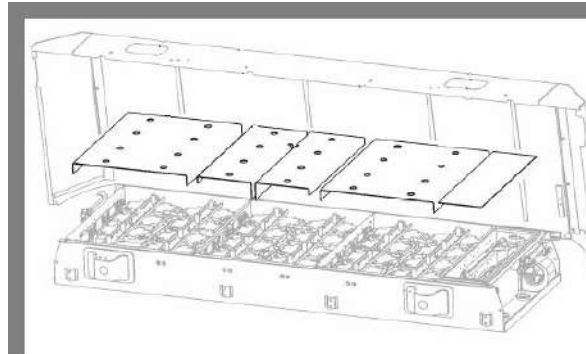
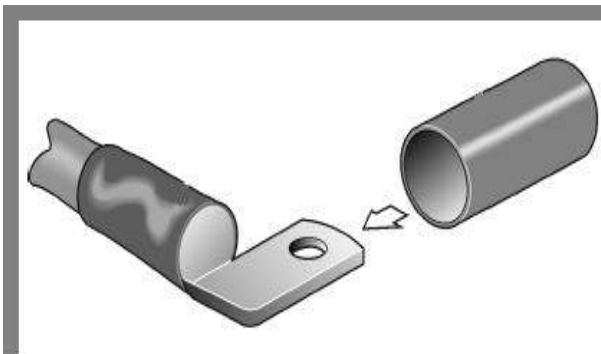





# ORION SERVICE

MOVING AT THE SPEED OF SOUND

0446

**QUESTIONS? GIVE US A CALL!**

**SERVICE USA & WARRANTY**

**800-716-7466**

**PARTS NORTH AMERICA**

**800-786-8099**

