

INSTALLATION AND ADJUSTMENT PROCEDURES

ENTRANCE DOOR PNEUMATIC INWARD SLIDE GLIDE

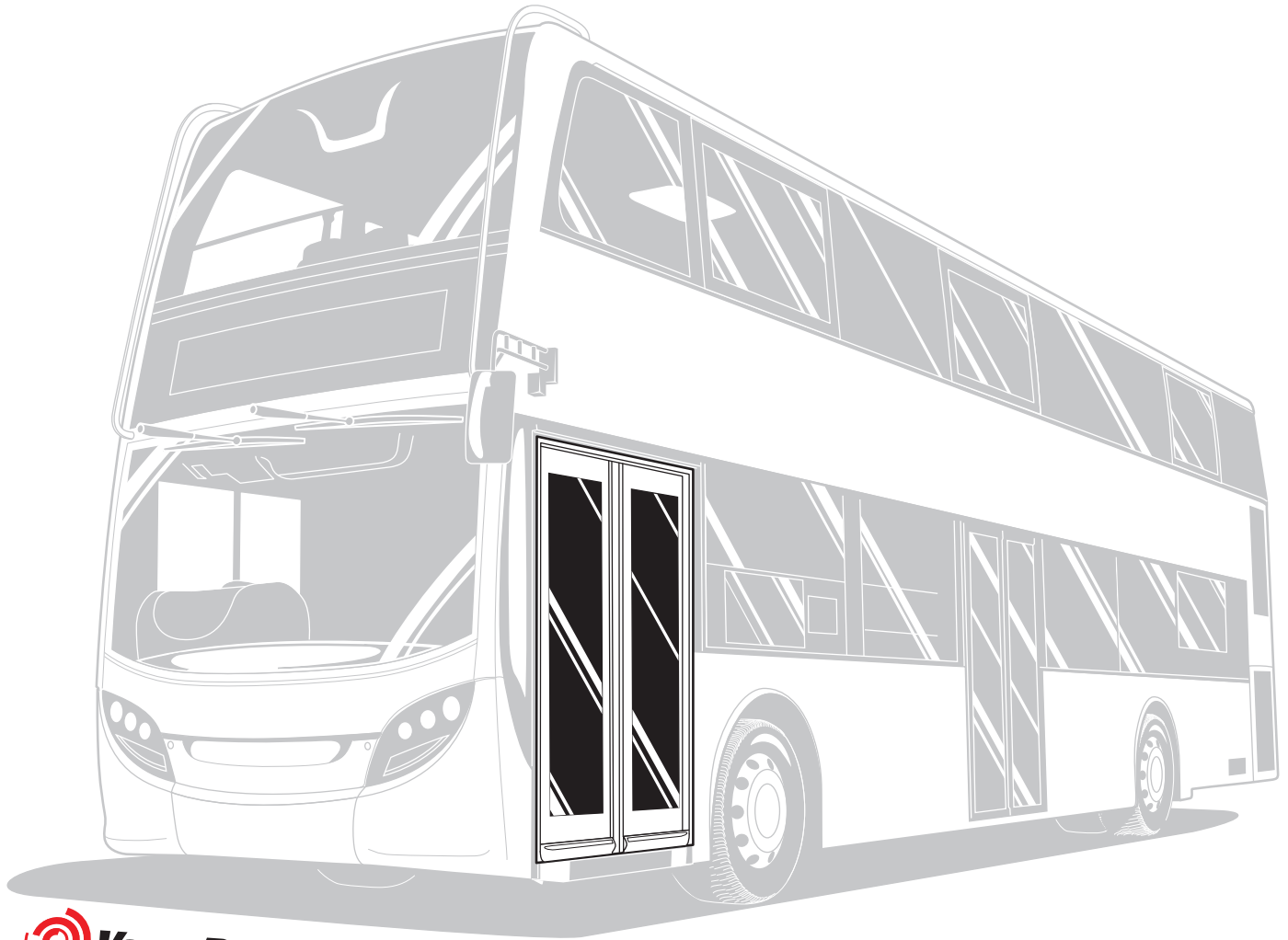

 **Vapor Bus International**
A Wabtec company

**Alexander Dennis
Enviro400**

**Bulletin No.: IAP-12-005
MRN: 03003-8
Revision: A
Rev. Date: 12 DEC 2012**

Table of Contents

INTRODUCTION	3
Door Opening Mechanism	3
Opening the Door	3
Closing the Door	3
CONTACT INFORMATION	3
General	3
Technical Support	3
SAFETY	4
General	4
Safety Alert Symbols	4
Safety Instructions	5
DOOR ASSEMBLY KITS	6
Unpacking Instructions	6
51250142 Door Portal Seal	6
51250140 Base Plate Kit Contents	6
51250141 Door Kit Contents	7
GENERAL INFORMATION	7
Reference Drawings	7
Tools Required	7
PRE-INSTALLATION INSTRUCTIONS	8
Disclaimer	8
Preparation	8
INSTALLATION INSTRUCTIONS	8
51250140 Base Plate Kit Installation	9
Emergency Open Switch (51057108-01)	12
Emergency Door Open Switch (51057125)	12
Door Close Switch (51250239)	13
51250141 Door Kit Installation	13
Shaft and Arm Assembly	13
Door Panel Installation	15
Door Alignment and Adjustment	16
Attach Cylinders to Shaft and Arm Assembly	19
51250142 Door Portal Seal Installation	20
Preloading and Door Stop Adjustment	21
Testing the Emergency Door Open Switches	23

Introduction

This manual describes installation and adjustment procedures for the Alexander Dennis Enviro400 electro-pneumatic front door power slide glide system.

Door Opening Mechanism

This door operating mechanism utilizes a pressurized air and electrical control system. It consists of a cylinder connected to a shaft and arm assembly, connected to a door panel. Air pressure from the bus is ported through a filter and pressure regulator to the base plate controls. When an electrical signal is received at the control, air pressure is directed to one end of the cylinder causing the doors to either open or close.

Opening the Door

When the driver's door controller is placed in the front-door-open-position, electrical contacts inside the controller's front door switch provide 24 Volts DC to energize a five-way solenoid valve. Once energized, the solenoid directs air pressure to the piston end of the cylinders, causing the rod to extend and open the doors. Air pressure is maintained on the cylinder to hold the doors open.

Closing the Door

When the driver's door controller is placed in the front-door-close-position, electrical contacts inside the controller's front door switch provide 24 Volts DC to energize a five-way solenoid valve. Once energized, the solenoid directs air pressure to the rod end of the cylinders, causing the rod to retract and close the doors. Air pressure is maintained on the cylinder to hold the doors closed.

Contact Information

General

Vapor Bus International, A Wabtec Company
1010 Johnson Drive
Buffalo Grove, IL 60089

Phone: (847) 777-6400
Fax: (847) 520-2222
Email: vaporbusinfo@wabtec.com

Technical Support

Available from 8:00 am to 4:00 pm Central Time USA

Phone: 866-375-4126
Email: techsupport@vaporddoors.com

Safety

General

Safety of the operator and bystanders is one of the main concerns in designing and developing a new piece of equipment. Designers and manufacturers build in as many safety features as possible. However, every year many accidents occur which could have been avoided by a few seconds of thought and a more careful approach to handling the equipment.

Most work related accidents are caused by failure to observe basic safety rules or precautions. An accident can often be avoided by recognizing potentially hazardous situations before an accident occurs. As you install, operate, or maintain the door system (unit), you must be alert to potential hazards. You should also have the necessary training, skills, and tools to perform any assembly or maintenance procedures.

Improper operation and maintenance of this unit could result in a dangerous situation that could cause injury or death.

WARNING

 **Do not install or operate the door system until you read and understand the information contained in this manual.**

 **Safety precautions and warnings are provided in this manual and on the unit. If these hazard warnings are not heeded, bodily injury or death could occur to you or to other persons.**

Vapor Bus International cannot anticipate every possible circumstance that might involve a potential hazard. The warnings in this manual and on the product are, therefore, not all-inclusive. If a method of installation or operation not specifically recommended by us is used, you must satisfy yourself that it is safe for you and for others. You should also ensure that the door system will not be damaged or be made unsafe by the methods that you choose.

The information, specifications, and illustrations in this manual are based on the information that was available at the time this material was written and can change at any time without notice.

Safety Alert Symbols



This is the safety alert symbol. It is used to alert you to potential personal injury hazards. Obey all safety messages that follow this symbol to avoid possible injury or death.

This manual contains DANGERS, SAFETY INSTRUCTIONS, CAUTIONS, IMPORTANT NOTICES, and NOTES which must be followed to prevent the possibility of improper service, damage to the equipment, personal injury, or death. The following key words call the readers' attention to potential hazards.

Hazards are identified by the "Safety Alert Symbol" and followed by a signal word such as "DANGER", "WARNING", or "CAUTION".

DANGER

Indicates an imminently hazardous situation which, if not avoided, will result in death or serious injury. This signal word is limited to the most extreme situations.

WARNING

Indicates a potentially hazardous situation which, if not avoided, could result in death or serious injury.

CAUTION

Indicates a potentially hazardous situation which, if not avoided, may result in minor or moderate injury.

NOTICE

Indicates that equipment or property damage can result if instructions are not followed.

SAFETY INSTRUCTIONS

Safety instructions (or equivalent) signs indicate specific safety-related instructions or procedures.

Note: Contains additional information important to a procedure.

Safety Instructions

WARNING



Read And Understand Manual

To prevent personal injury or even death, be sure you read and understand all of the instructions in this manual and other related OEM equipment manuals! This equipment, if not installed properly, can be dangerous to installers unfamiliar with its operation. Do not allow operation or assembly of this bus door system until the installers have read this manual and have developed a thorough understanding of the safety precautions and how it works.

This unit was designed for a specific application; **DO NOT** modify or use this unit for any application other than which it was designed.

Units operated improperly or by untrained personnel can be dangerous!



Damaged Parts Hazard

Do not install this unit if it is damaged. If you believe the unit has a defect which could cause it to work improperly, you should immediately stop the installation and remedy the problem before continuing.



Impaired Installer Hazard

Do not attempt to install this unit under the influence of drugs or alcohol. Review all the safety instructions with installers annually.

Personal Protection Equipment

When installing or operating this unit, wear appropriate personal protective equipment. This list may include but is not limited to:



- A hard hat
- Protective shoes with slip resistant soles
- Protective goggles, glasses, or face shield
- Protective clothing

SAFETY INSTRUCTIONS

Follow all installation and safety instructions found in this manual.



Understand the installation procedure before performing the work. Keep work area clean and dry.



Make sure all parts are in good working condition and properly installed. Replace any damaged parts immediately.



Do not leave used tools lying around the work area.



Do not modify door system or safety devices. Do not weld on the unit. Unauthorized modifications may impair its function and safety.



If equipment has been altered in any way from the original design, the manufacturer does not accept any liability for injury or warranty.



If replacement parts are necessary, genuine factory replacement parts must be used to restore the unit to original specifications. The manufacturer will not accept responsibility for damages as a result of the use of unapproved parts.

Door Assembly Kits

A complete bus door installation requires three kits; a door seal kit, a base plate kit, and a door kit. Read these installation instructions carefully and familiarize yourself with the various parts of each kit before starting the installation process.

Unpacking Instructions

1. Carefully unpack the door system components and inspect them for any damage that may have occurred during shipment.

SAFETY INSTRUCTIONS

The door opening and closing cylinders are secured to the base plate with tie wraps to prevent unwanted movement during installation. Do not remove the factory installed tie wraps until after the base plate is installed.

2. Make sure the electrical control components and wiring are not damaged. Verify that no wires or terminals are broken or loose.
3. Verify that the limit switches on the door operator assembly and base plate assembly have not been damaged.
4. Replace any damaged components before attempting to install the door system.

51250142 Door Portal Seal

51250142 Door Portal Seal			
Item	Qty.	Part Number	Description
1	1	51250142	Door Portal Seal

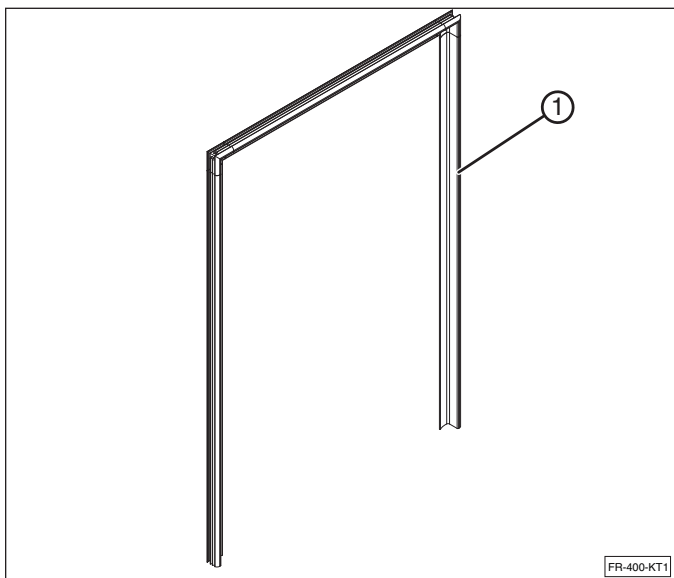

51250140 Base Plate Kit Contents

51250140 Base Plate Kit			
Item	Qty.	Part Number	Description
1	1	51250230	Base Plate Assembly
2	1	51250316	C-Channel (Base Plate Mount)
3	1	51057120	Filter/Regulator Assembly
4	1	51057108-01	Door Open Push Button (External)
5	1	51057125	Door Open Push Button (Internal)
6	1	51250239	Door Close Push Button
7	6000 mm	51057095	Tubing, 4 mm Diameter, Black
8	6000 mm	51057095-01	Tubing, 4 mm Diameter, Red
9	15000 mm	51057157	Tubing, 8 mm Diameter, Blue

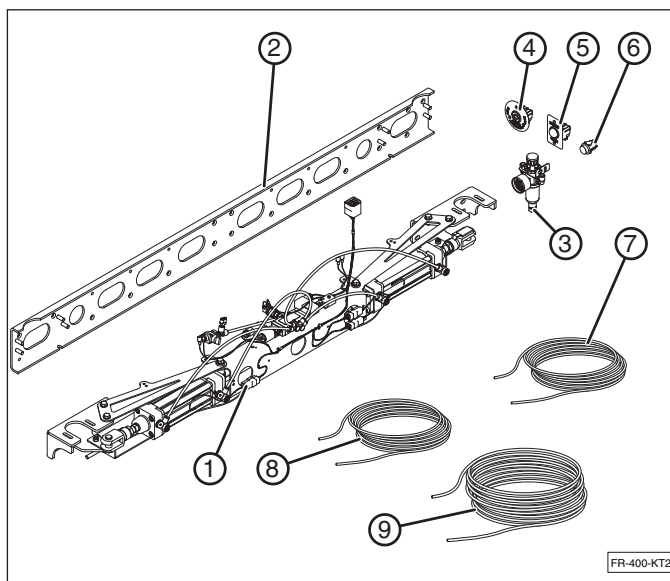

51250141 Door Kit Contents

51250141 Door Kit			
Item	Qty.	Part Number	Description
1	1	51057010-02	Shaft & Arm Assembly (RH)
2	1	51057010-03	Shaft & Arm Assembly (LH)
3	1	51250232	Door Assembly (RH)
4	1	51250232-01	Door Assembly (LH)
5	1	51250238	Bracket Assembly Lower Pivot (RH)
6	1	51250238-01	Bracket Assembly Lower Pivot (LH)

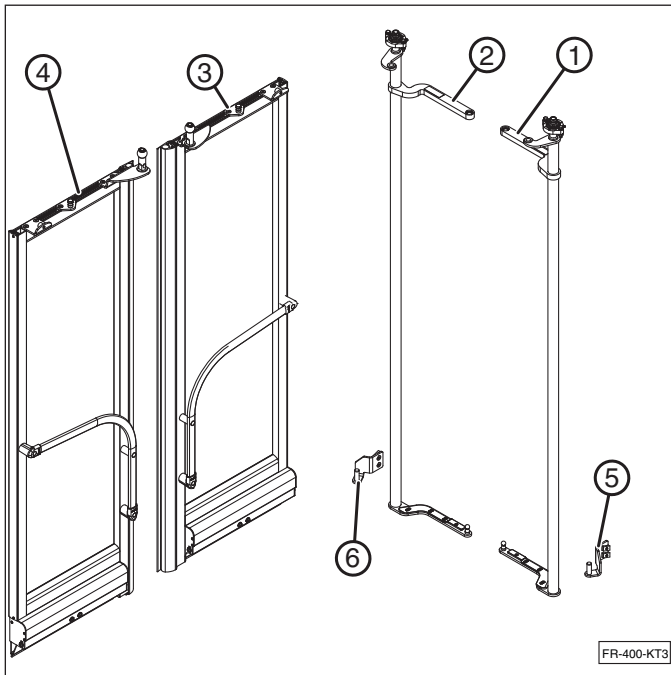

General Information

Reference Drawings

Use the information contained in this manual and the reference drawings listed in the table to install the door system.

Installation Reference Drawings	
Description	Drawing Part Number
Application Drawing	51205022
Base Plate Assembly and Control Kit	51250140
Door Panel Kit and Shaft and Arm Kit	51250141
Portal Seal	51250142
Connection Diagram	51205039
Pneumatic Diagram	51205040

Tools Required

Tools	
Tool	Usage
Allen Wrench Set (Metric)	Door speed adjustment (cylinder) and door alignment adjustment.
Socket or Wrench Set (Metric)	Door installation and cylinder rod adjustment.
Spanner Wrenches, Two 38 mm	Door height adjustment (shaft and rod assembly).
Torque Wrench	Various screws and bolts.
Utility Knife	Trim door seal to fit around lower hinge plate.
Phillips Screwdriver	Various screws.
Tape Measure	Check door opening size and squareness.
Stop Watch	Check door opening and closing times.

Pre-Installation Instructions

Disclaimer

The information contained in this Installation and Adjustment Manual is based upon reliable technical data at the time the manual was published. These instructions are intended for use by persons having the technical knowledge to install this door system. The instructions are to be used at the installer's own discretion and risk. Vapor Bus International assumes no responsibility for results obtained or damage incurred from the use of this material either in whole or in part by the installer.

This manual provides basic instructions for the installation of the door system in a step-by-step sequence that will work in most types of installations. If there is an installation application that is not covered in this manual, please contact Vapor Bus International for additional information concerning that application.

WARNING

Follow all installation instructions. Failure to follow these instructions could result in personal injury or damage to the bus frame.

Preparation

Before beginning the installation, make sure the door opening is the correct size and that it is square.

1. The width of the door frame should be 1291 ± 5 mm (50.83 ± 0.20 in).
2. The height of the door frame from the step edge to the lintel should be 1894 ± 5 mm (74.57 ± 0.20 in).
3. Also check for squareness of the opening. This cross measurement should be approximately 2292 mm (90.24 in). The measurement will vary depending on the height and width of the opening, however, both measurements should be equal.

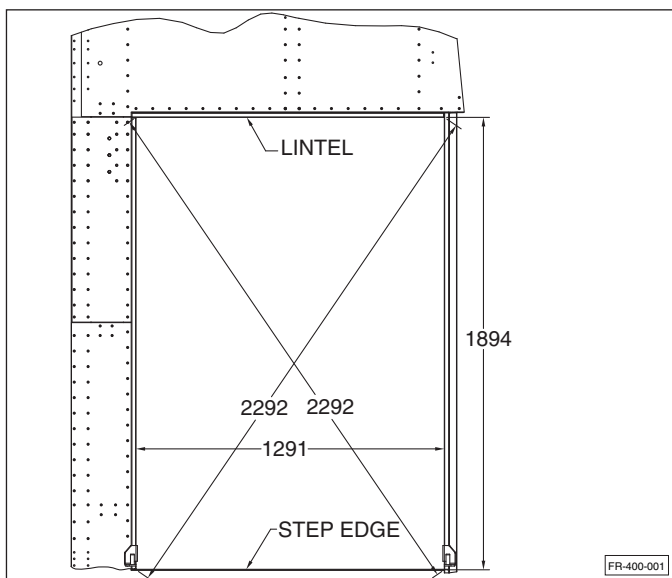

Installation Instructions

The installation instructions are organized by kits.

1. Install the Base Plate Kit.
2. Install the Door Kit.
3. Install the Door Portal Seal.
4. Make the required door adjustments.
5. Inspect all the components to make sure they operate properly.

51250140 Base Plate Kit Installation

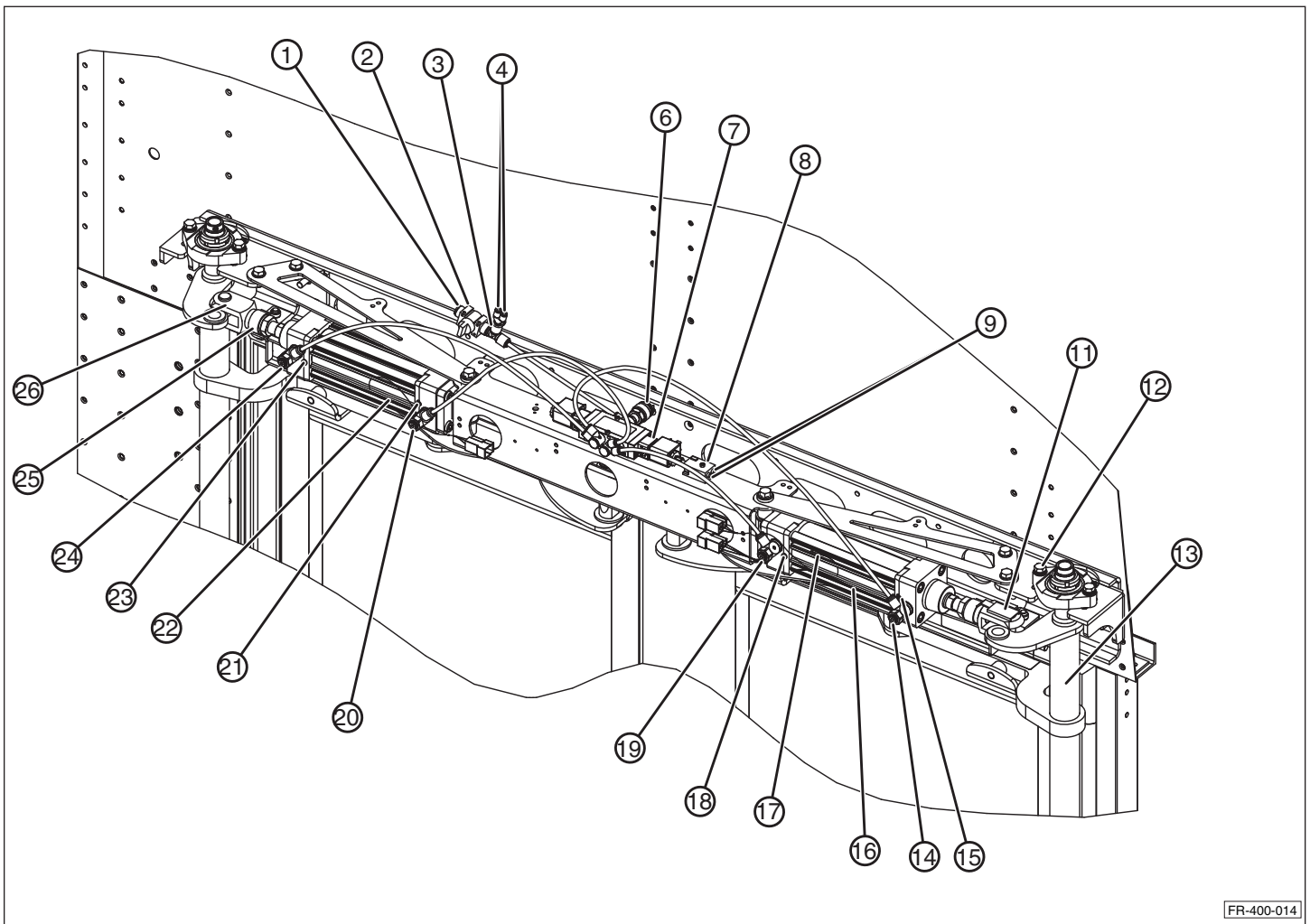

Base Plate Nomenclature	
Item	Description
1	Air Line Inlet From Regulator Valve
2	On/Off Ball Valve
3	Push-Button Air Supply Connection
4	Air Line Connections to Emergency Open Buttons
5	Not Used
6	Pressure Switch
7	Door Valve Assembly
8	“Or” Valve (Push-Button Signal Connection)
9	Air Line Connections f rom Emergency Open Buttons
10	Not Used
11	Clevis Retaining Pin With Spring Clip
12	Shaft And Arm Assembly Flange Bearing
13	Shaft And Arm Assembly
14	Forward Door Open Speed Control Setting
15	Forward Door Open Cushion Control Setting
16	Forward Door Close Cushion Control Setting
17	Forward Door Open Sensor (Reed Switch)
18	Forward Door Close Sensor (Reed Switch)

Base Plate Nomenclature (continued)	
Item	Description
19	Forward Door Close Speed Control Setting
20	Rearward Door Close Speed Control Setting
21	Rearward Door Open Cushion Control Setting
22	Rearward Door Close Sensor (Reed Switch)
23	Rearward Door Close Cushion Control Setting
24	Rearward Door Open Speed Control Setting
25	Cylinder Rod Clevis
26	Clevis Lock Nut

1. Install the pressure regulator between the air compressor on the bus and the base plate. The pressure should be adjusted to 7 bar+. A small arrow under the pressure gauge indicates the direction of air flow.

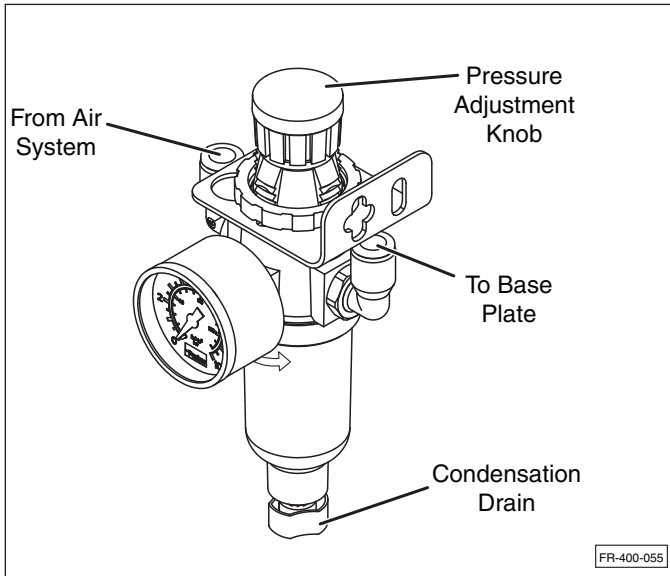

2. Install the C-channel above the door frame.

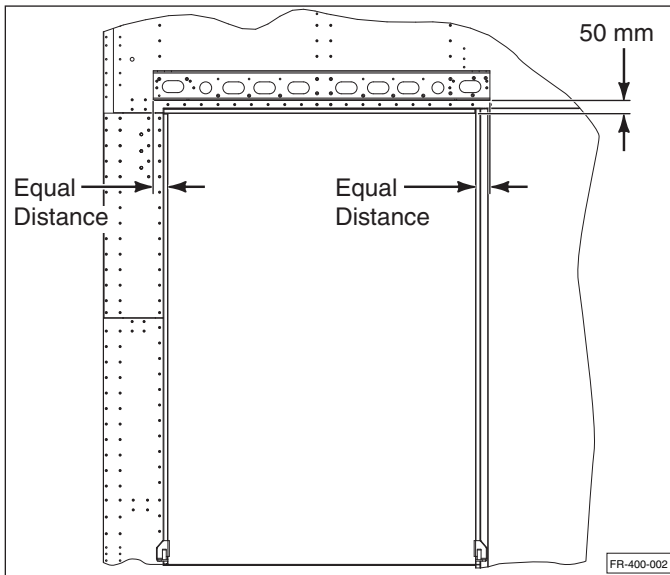

- a. Center the C-channel from side-to-side in the door opening with an equal amount on either side of the opening.
- b. Position the C-channel 50 mm (1.97 in) above the bottom of the lintel, as shown.

⚠ WARNING



FALLING HAZARD

The door operating mechanism (base plate) weighs 16 kg (35 lbs.) and is directly attached to the C-channel. It is the installer's responsibility to securely fasten the C-channel in such a manner as to prevent this part from separating from the bus frame or interior mounting surface. Severe injury and possible death can occur if this unit falls on a passenger.

3. Securely fasten the C-channel to the interior surface of the bus. The C-channel has seven 6.6 mm predrilled holes (2) and seventeen 6.6 mm predrilled countersunk holes (countersink diameter 13 mm x 90 degrees) (1). The hardware for mounting the C-channel must be supplied by the installer.

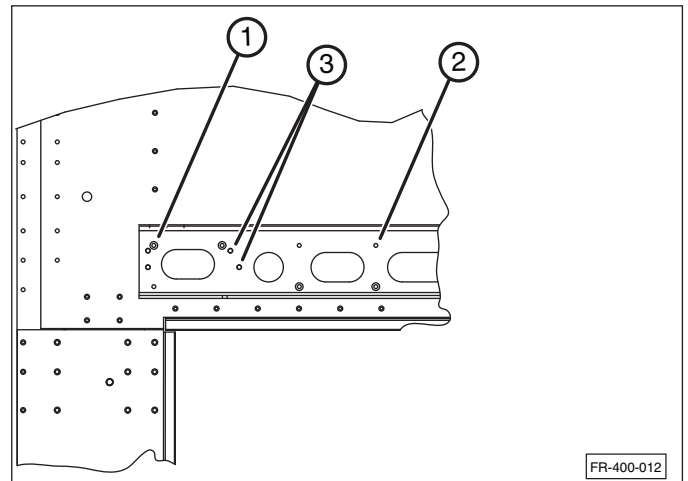

(1) Standard M6 bolt hole. (2) Countersink M6 bolt hole. (3) Base plate mounting stud.

⚠ CAUTION

The base plate weighs 16 kg (35 lbs.) and should be installed by two people due to its weight and overall size. Overhead installation by one person could result in personal injury.

4. Attach the base plate to the C-channel.

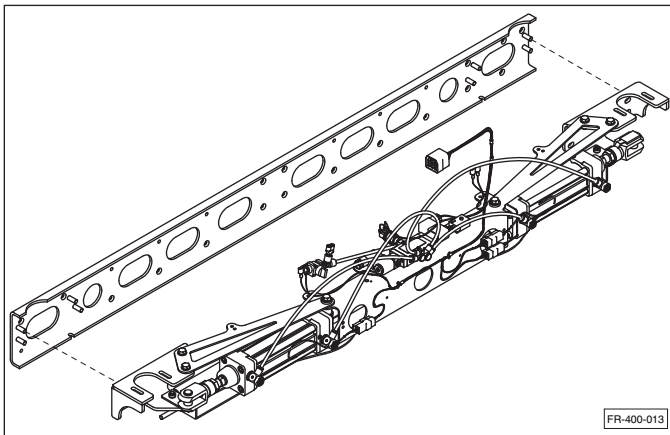

- a. Place the base plate over the eight studs in the C-channel.
- b. Install an M8 washer, M8 lock washer, and M8 nut on each stud. This mounting hardware must be supplied by the installer.

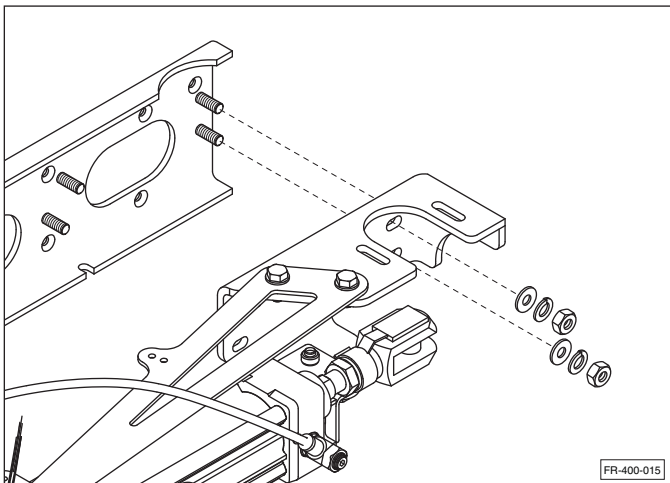

- c. Tighten all the nuts snugly, but not completely tight.
- d. Now center the base plate in the frame opening and tighten the nuts to 25 N·m (18 lb.ft.).

Note: Slotted holes in the base plate allow it to move from side-to-side in order to center it in the door opening.

5. Connect the 11 pin electrical plug from the base plate into the bus wiring harness.

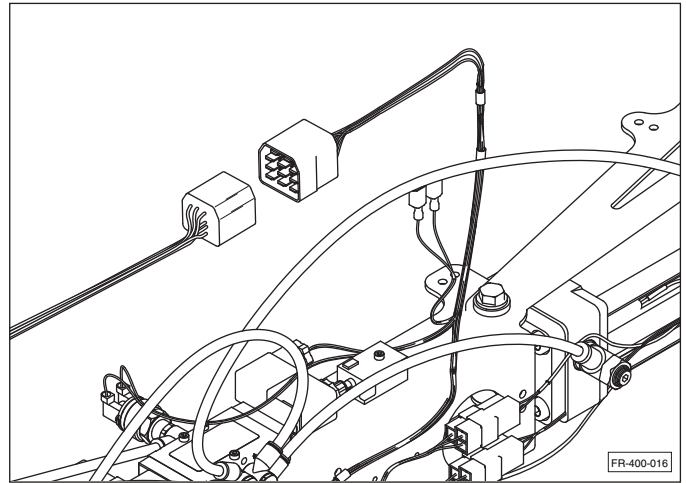

6. Set the mini ON/OFF ball valve in the OFF position and connect an air supply line from the regulator to the valve. Use the 8 mm blue tubing (51057157), supplied in the kit, for this connection.

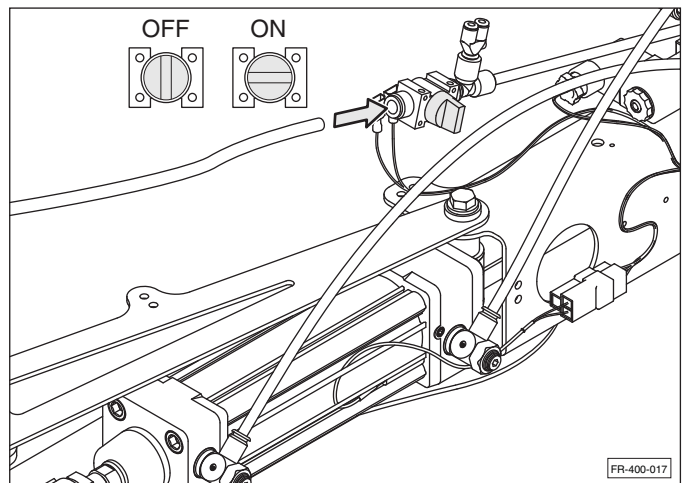

⚠ CAUTION



PINCH POINT HAZARD
Once air pressure is applied to the base plate, the door opening cylinders can activate causing the doors to either open or close. To prevent personal injury make sure the area is clear of all people.

Emergency Open Switch (51057108-01)

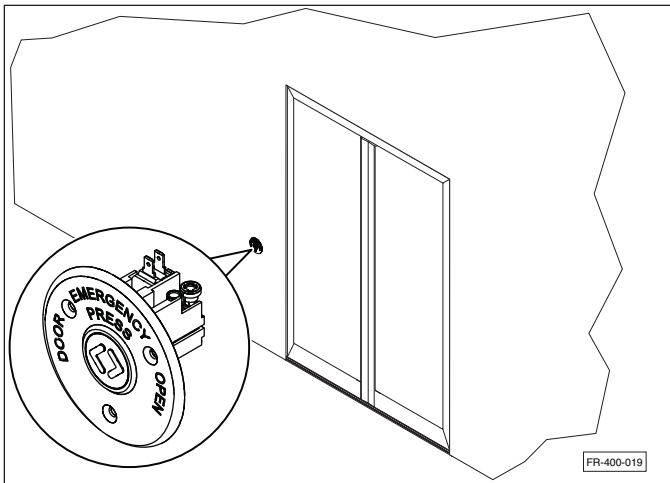

1. Install the emergency door open switch on the exterior of the bus in any desired location meeting local or national codes.
2. Connect the two electrical terminals on the switch to the bus electrical wiring harness.
3. Connect the two air line ports of the switch to the base plate, as shown, using two 4 mm plastic air lines. The installation kit comes with black and red air lines for these connections.

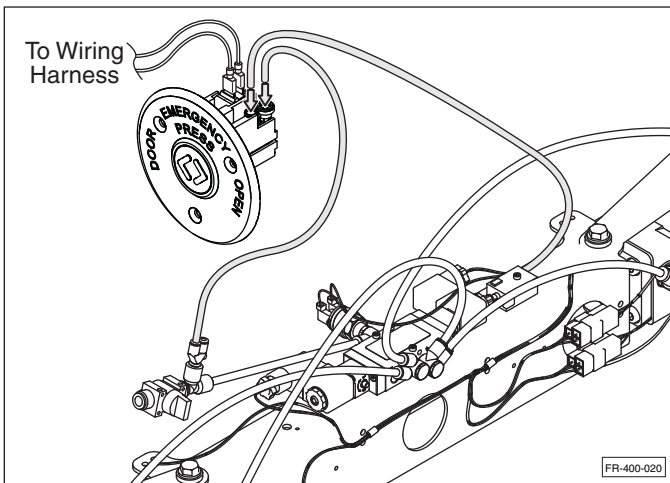

Note: Testing the operation of the switch will be done at the end of the installation procedure.

Emergency Door Open Switch (51057125)

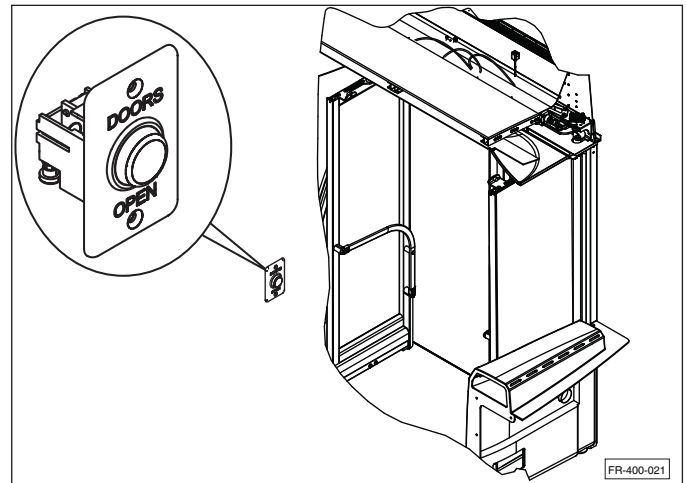

1. Install the emergency door open push button inside the bus in any desired location meeting local or national codes..
2. Connect the two electrical terminals on the switch to the bus electrical wiring harness.
3. Connect the two air line ports of the switch to the base plate, as shown, using two 4 mm plastic air lines. The installation kit comes with black and red air lines for these connections.

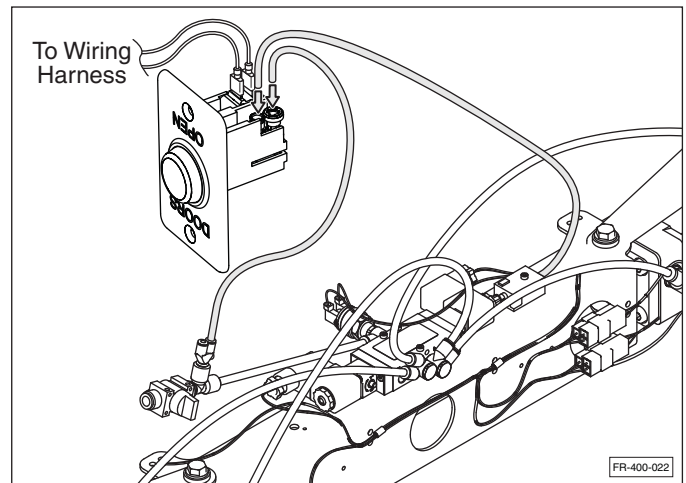

Note: Testing the operation of the switch will be done at the end of the installation procedure.

Door Close Switch (51250239)

1. Install the door close push button in any desired interior location meeting local or national codes..
2. Connect the two electrical terminals on the switch to the bus electrical wiring harness.

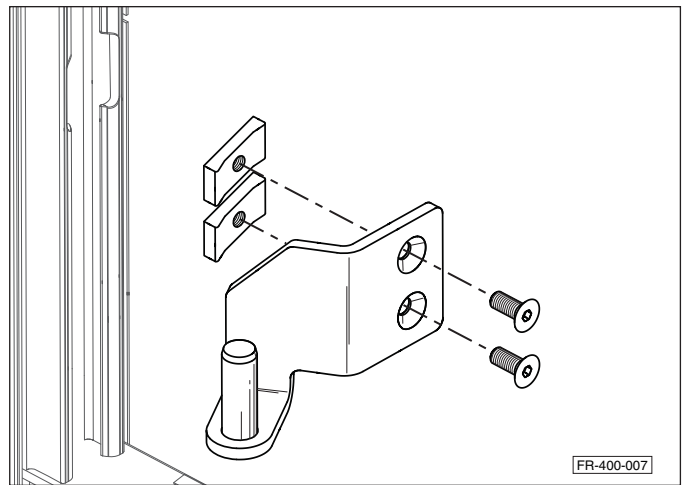
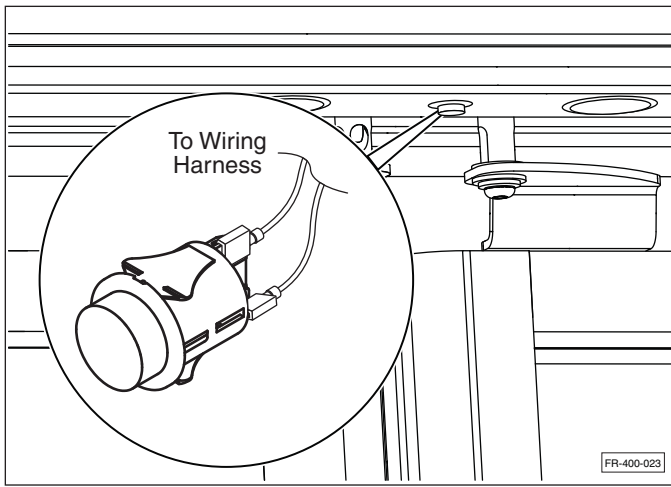

2. Insert the tee nuts through the slot in the door frame.

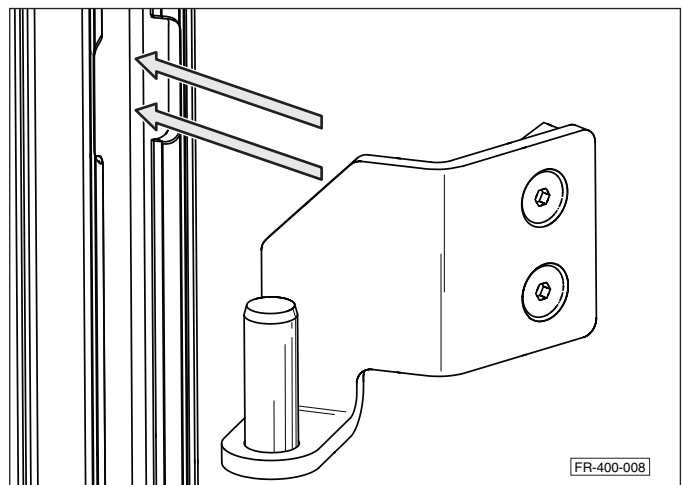

51250141 Door Kit Installation

Shaft and Arm Assembly

Install the two shaft and arm assemblies.

51057010-02 Right-hand Shaft and Arm Assembly

51057010-03 Left-hand Shaft and Arm Assembly

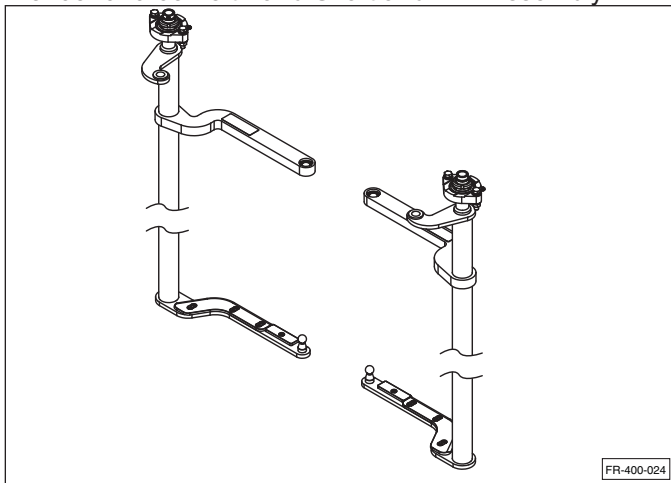

1. Install the right and left-side lower pivot bracket assemblies from the 51250141 Door Kit. If necessary, assemble the two tee nuts onto the hinge using two M8 flat head screws, supplied with kit.

3. Measure 1812 mm (71-11/32 in) from the lintel to the top of the lower pivot bracket assembly, as shown. Tighten the screws with a 5 mm Allen wrench to 17 N·m (25 lb.ft.).

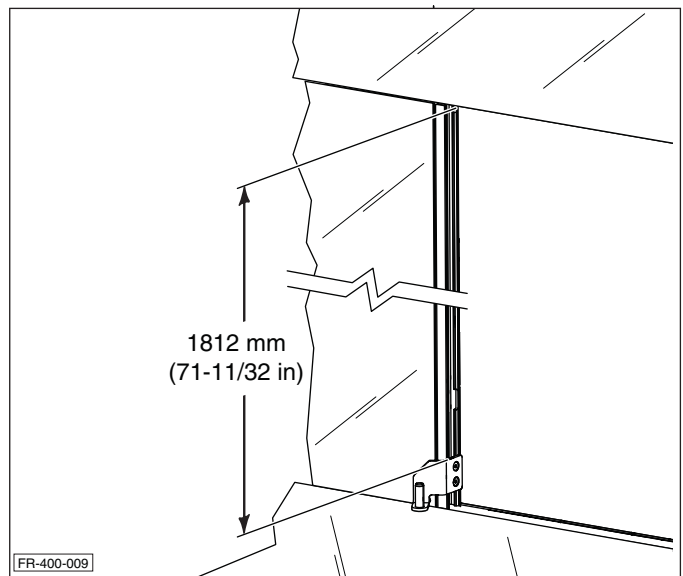

4. Remove the bolt, washers, lock washers, and nuts from the flange bearing.

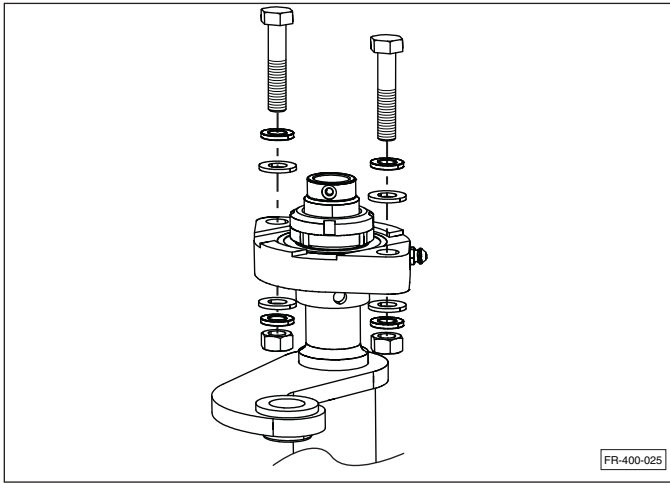

5. Slide the shaft and arm assembly onto the pin of the lower pivot bracket.

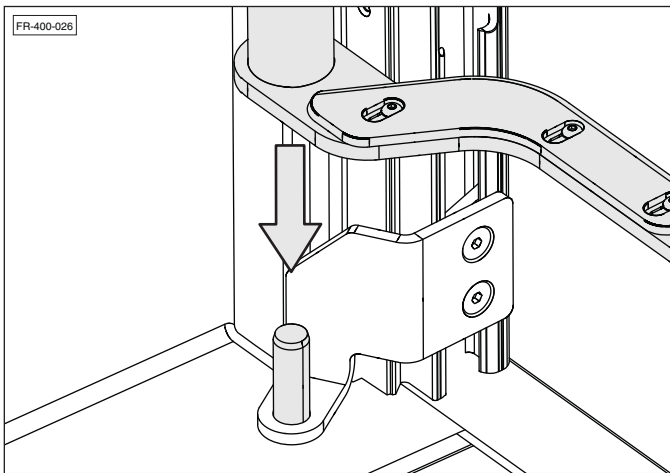

6. Insert the upper flange bearing into the slot in the base plate assembly.

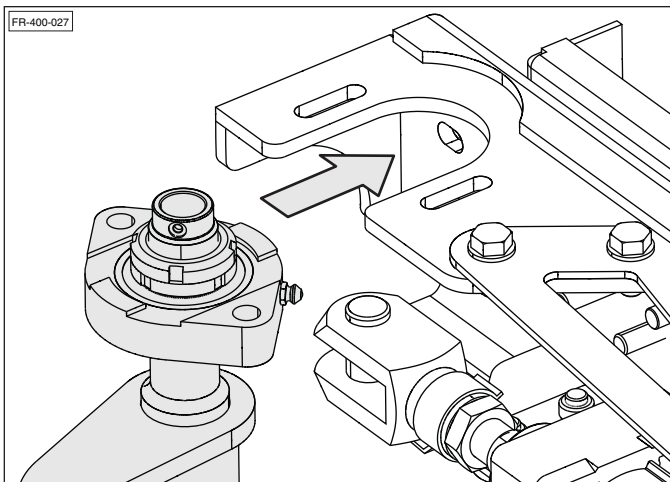

7. Align the two bolt holes and install the bolts, washers, lock washers, and nuts previously removed, as shown.

8. Tighten the bolts snugly, but do not completely tighten at this time.

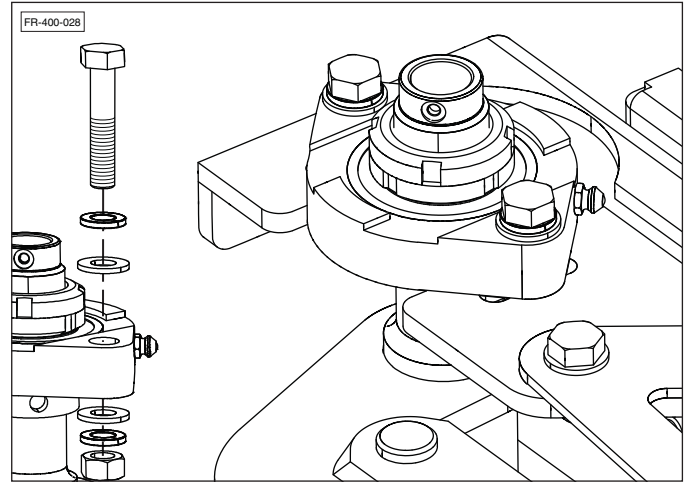

9. Repeat Steps 1 through 5 for the other shaft and arm assembly.

Door Panel Installation

Install the two door assemblies onto the shaft and arm assemblies.

51250232 Right-hand Door Assembly

51250232-01 Left-hand Door Assembly

CAUTION

Each door assembly weighs 23 kg (51 lbs.) and should be installed by two people due to its weight and overall size. Overhead installation by one person could result in personal injury.

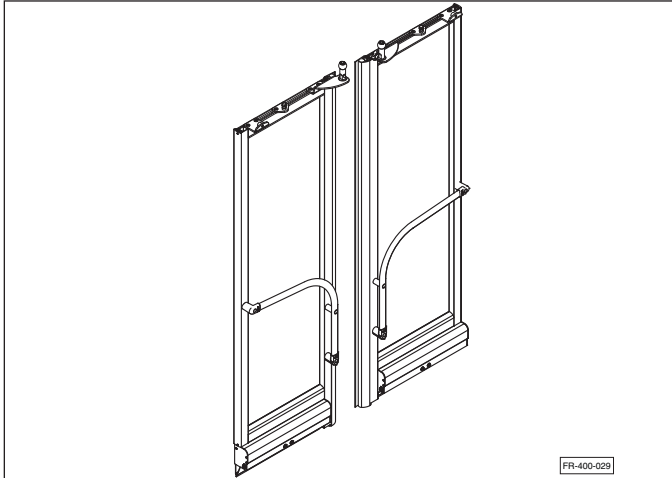

1. Remove the bolt and washer from the upper hinge bracket.

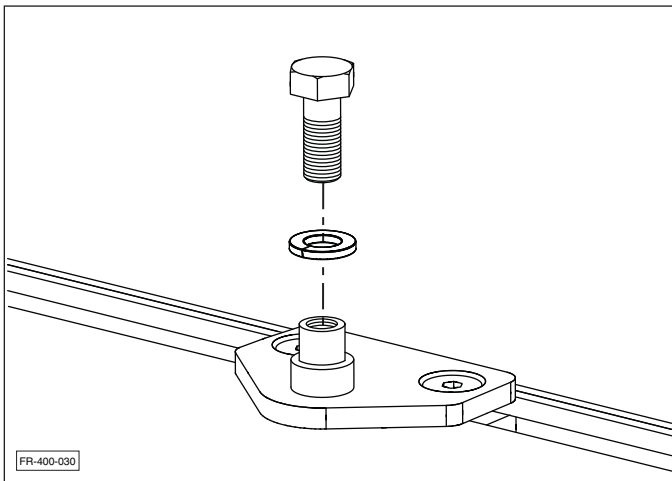

2. To make installation easier, mount the door perpendicular to the door opening. Lift the door panel assembly and guide the roller bracket assembly ball into the roller channel of the base plate.

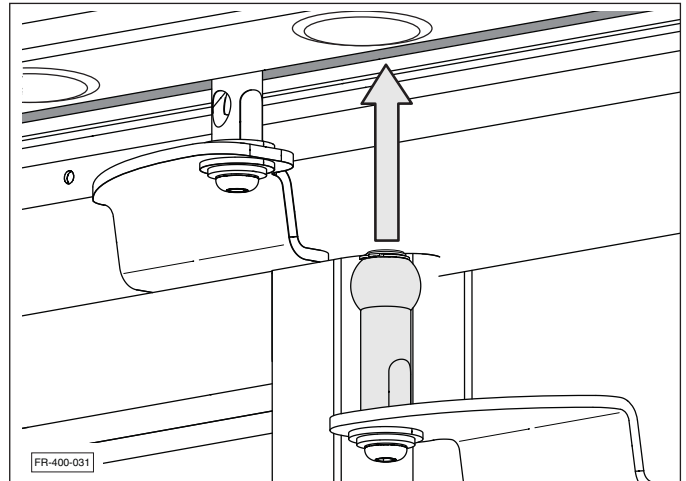

3. Lower the door onto the lower arm pivot ball.

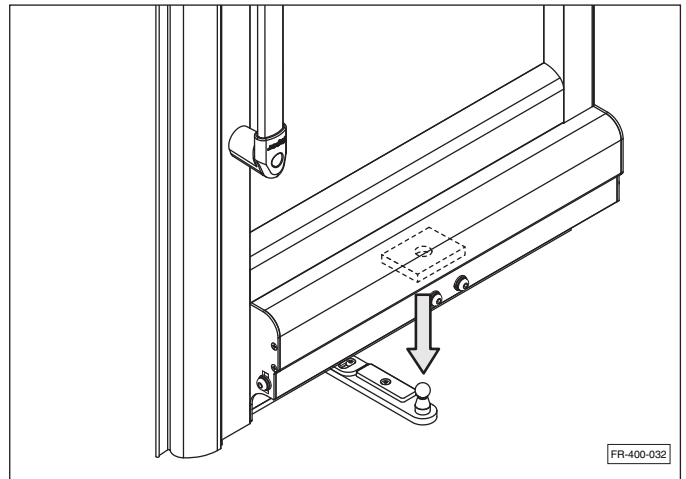

4. Align the hole in the upper hinge bracket with the hole in the upper arm. Apply 67110007-14 (Loctite #242) to the threads of the M10 hex bolt. Install the bolt and washer.

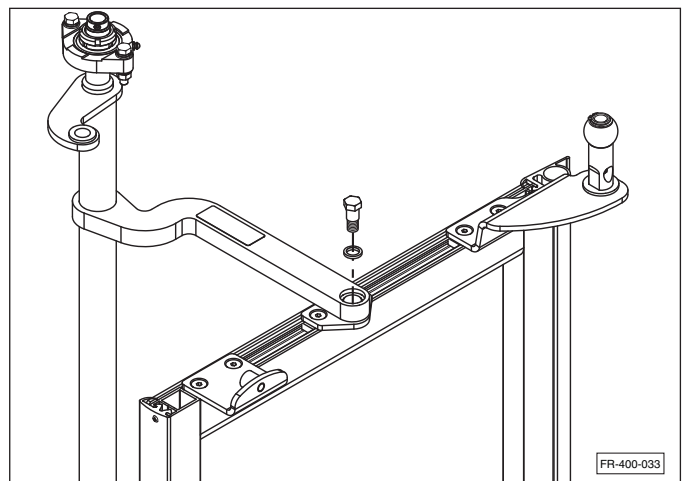

5. Close both doors to measure height. The top rail of the door should be 50 mm (2 in.) from the lintel, as shown.

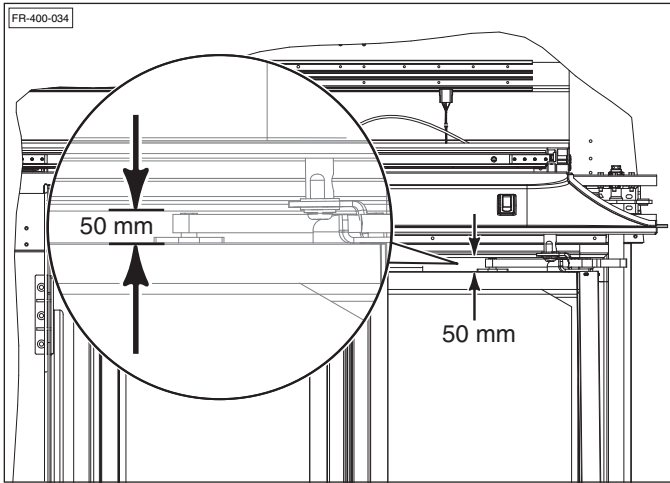

6. If the doors are equipped with the optional sensing edge, connect two wires from each door to these terminals.

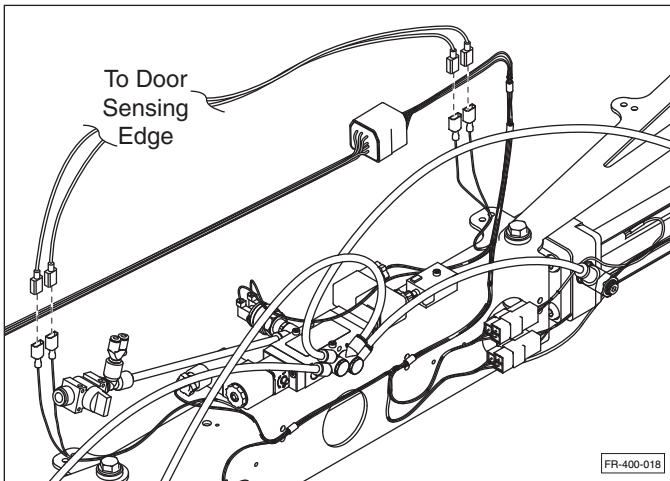

Door Alignment and Adjustment

Note: Make only one adjustment at a time because making an adjustment to one area of the door can affect another area.

1. Adjust the height of the doors.

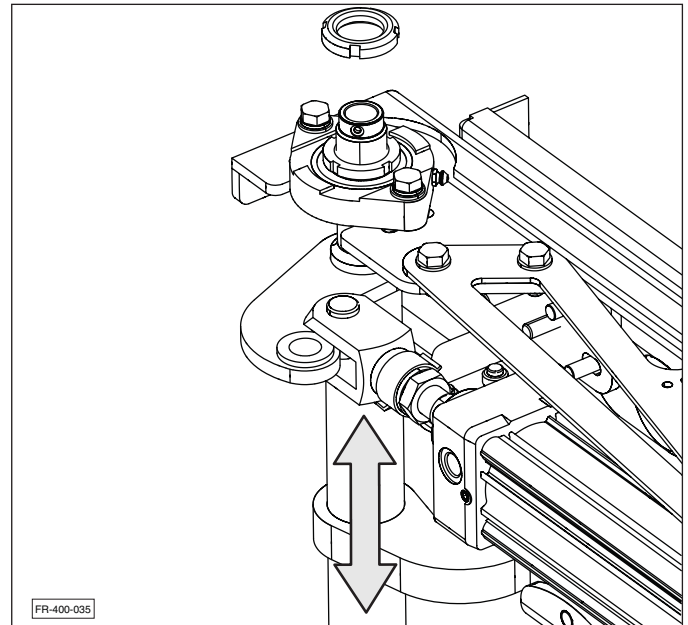

- a. Loosen the upper locking spanner nut sufficiently to make the necessary adjustment.
- b. Rotate the other spanner nut to either raise or lower the shaft and arm assembly along with the door assembly.
- c. Adjust the doors to the correct height and make sure the door assemblies are equal to each other.
- d. When the adjustment is complete, install and tighten the second spanner nut against the first. Tighten the lock nuts on the other shaft and arm assembly also.

Note: Adjusting the height of the door will require adjustment to the lower active seal bracket. Refer to the next step.

2. Adjust the lower active seal to make contact with the bus floor.

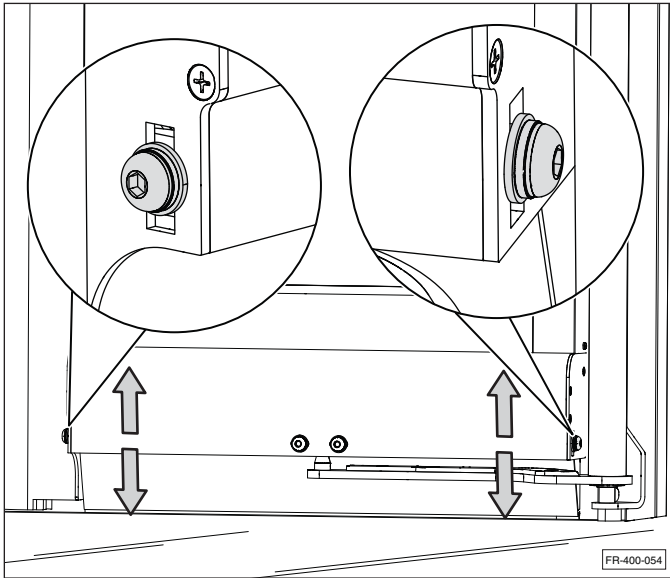

- a. Loosen the M8 hex socket button head cap screws on each side of the lower active seal bracket.
 - b. Raise or lower the seal to make contact with the bus floor.
 - c. Tighten the screws to 17 N·m (12.5 lb.ft.).
3. Adjust the inward/outward alignment of the doors to the bus frame.

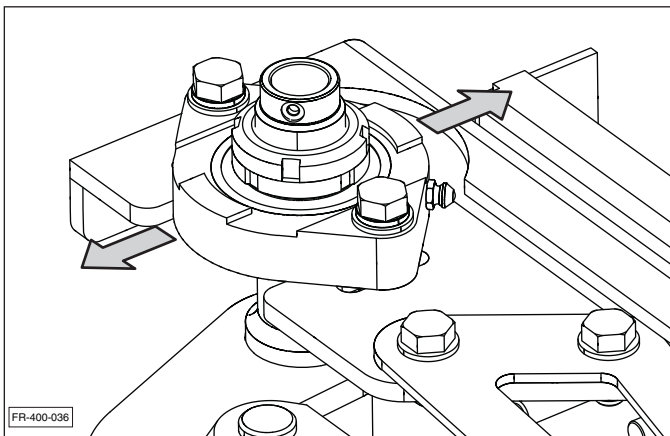

- a. Loosen the two flange bearing bolts.
- b. Adjust the shaft and arm assembly inward or outward until the doors are properly aligned with the bus frame.

Note: The door seal should apply even pressure to the door from the top to the bottom when the door is properly aligned.

- c. Tighten the nuts to 17 N·m (12.5 lb.ft.).

4. Adjust the side-to-side alignment of the doors. The end result of this adjustment procedure is for the doors to fit squarely into the opening and have the correct spacing between the two doors.

- a. Measure the distance between the two doors, as shown. This distance should be 105 mm \pm 3 mm (4-1/8 in \pm 1/8 in) when measured at the top of the door or at the bottom. This distance is the metal-to-metal measurement. Adjust the door for proper alignment.

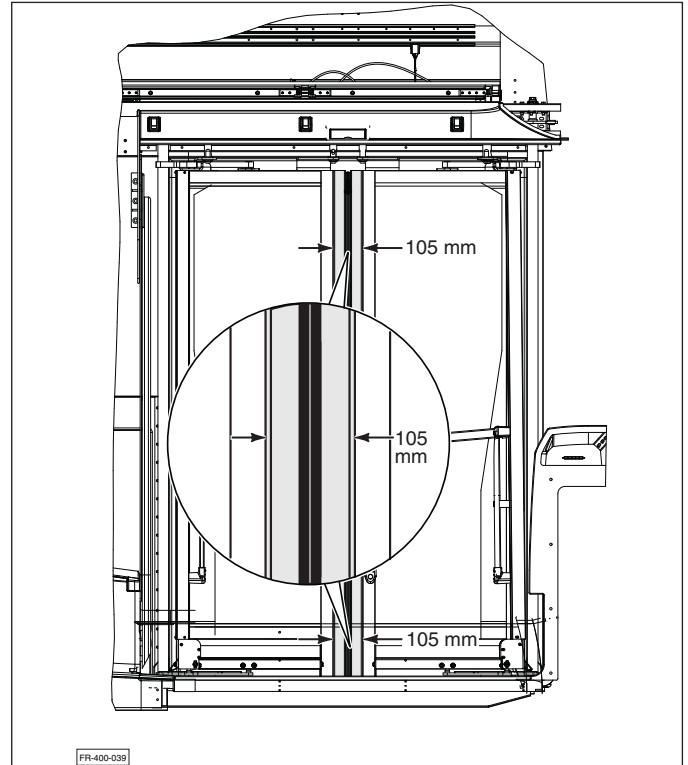

- b. Slightly loosen the two screws at the bottom of each door to allow the door hinge socket to move.

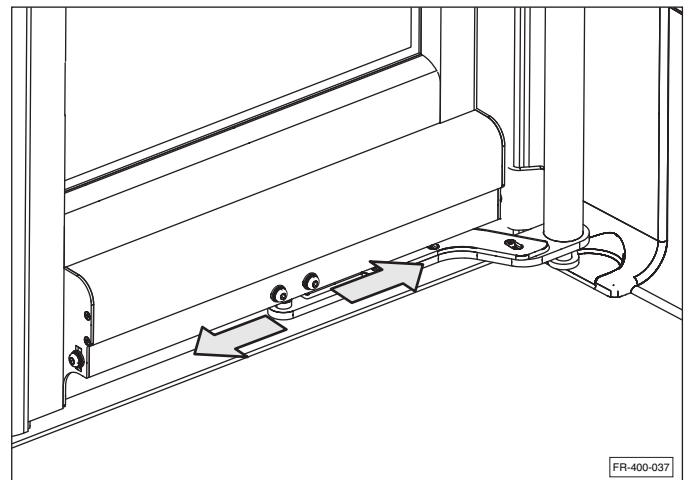

- c. Slightly loosen the two screws on the hinge plate at the top of the door.

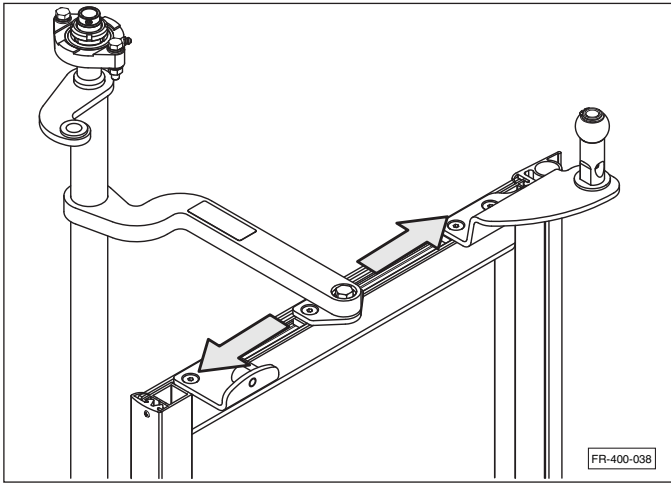

- d. Adjust the door for proper alignment so it fits in the opening with equal space on both sides while maintaining the 105 mm ± 3 mm (4-1/8 in ± 1/8 in) spacing in the center.

- e. Tighten all the screws to 17 N·m (12.5 lb.ft.).

5. Using an 8 mm hex socket wrench, adjust the roller pin. When correctly adjusted, the doors in the closed position, should be parallel with the outside surface. Retighten the screws to 107 N·m (79 lb.ft.).

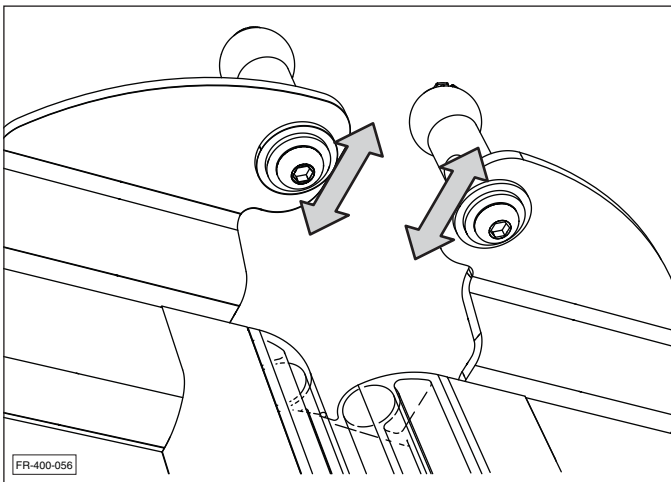

6. Fully open each door. If the doors do not open fully (90 degrees in respect to the step edge), adjust the respective roller brackets.

- a. Loosening the two hex socket screws and adjust the bracket until the door is perpendicular, as shown.

- b. Retighten the screws to 17 N·m (12.5 lb.ft.).

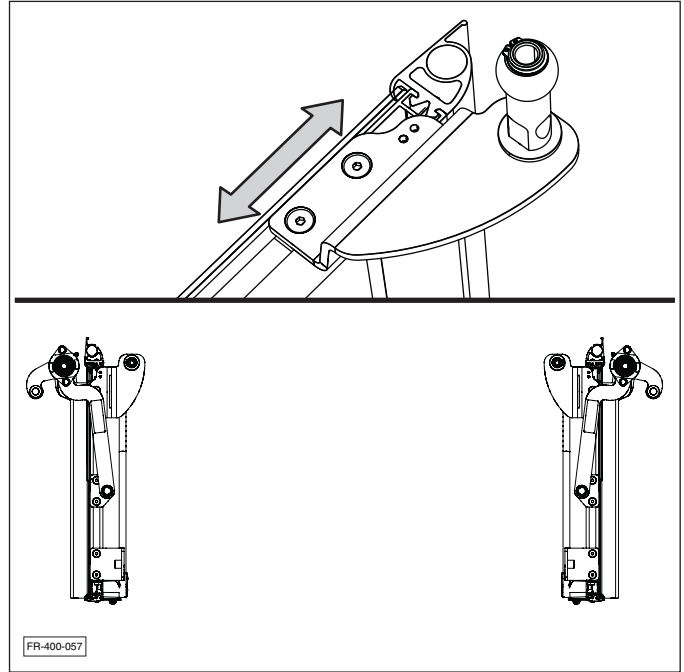

7. Move the doors independently from the closed to open position, verifying that no binding occurs.

CAUTION



PINCH POINT HAZARD

To prevent personal injury, do not place hands or fingers between moving and/or stationary parts.

Attach Cylinders to Shaft and Arm Assembly

1. Turn the main air valve to the OFF position to prevent unwanted movement of the cylinder rod.

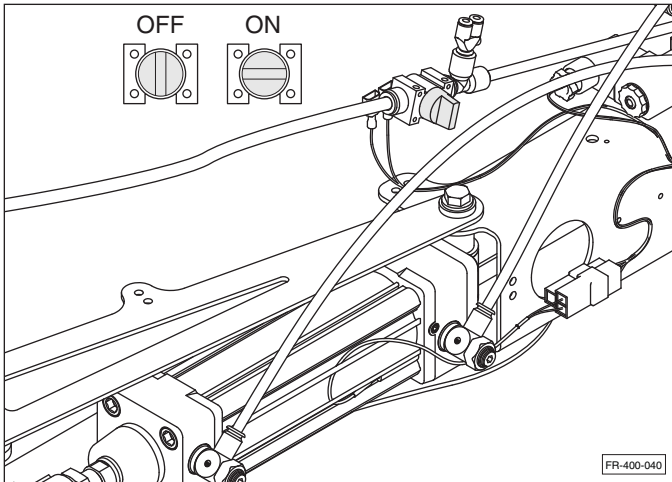

2. Remove the spring clip retainer pin from the clevis on the cylinder rod.

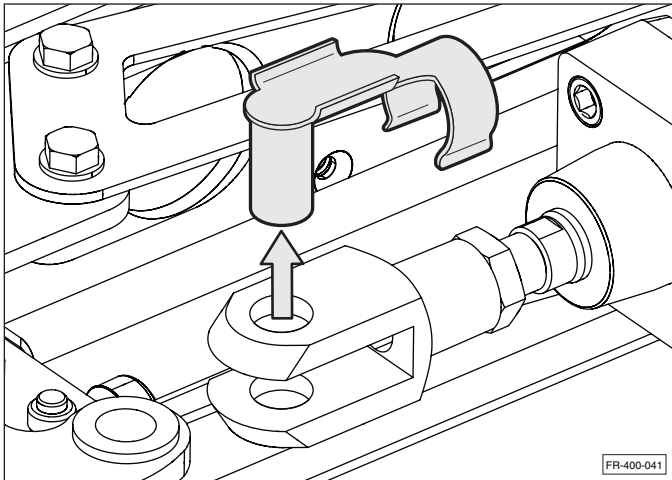

3. Align the cylinder rod with the hole in the shaft and arm assembly and install the spring clip retainer pin.
 - a. Close the rearward door panel, as viewed from the inside.
 - b. Position the cylinder rod with approximately 6 mm of exposed rod, as shown.

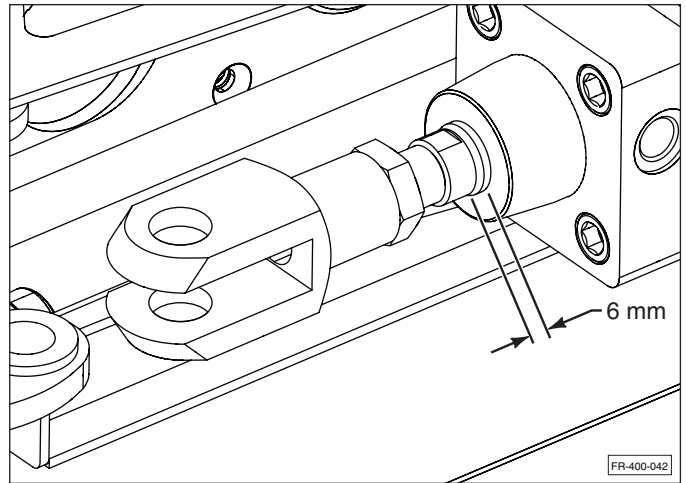

- c. Loosen the lock nut securing the cylinder rod clevis.
- d. Hold the cylinder rod with a wrench and rotate the clevis until the retaining pin will slip into the hole in the door shaft arm.
- e. Preload the cylinder by shortening each clevis one turn. It may be necessary to shorten it more during the final adjustment. Do not shorten the clevis more than two full turns.

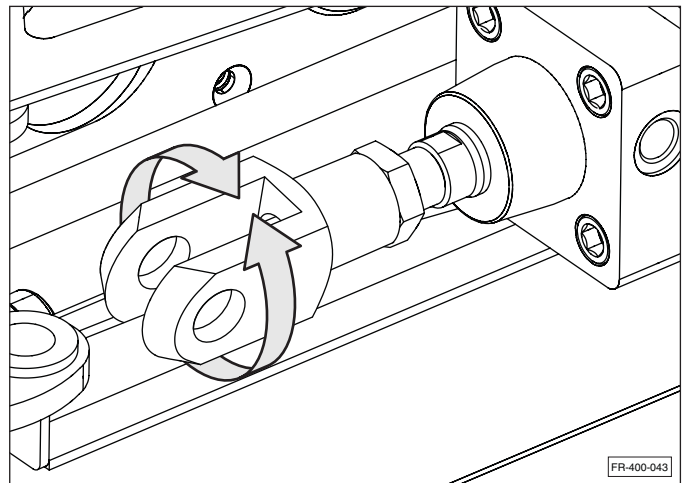

- f. Install the spring clip retainer pin. Make sure the spring clip is securely fastened around the clevis.
- g. The exposed thread length on the cylinder rod should be close to equal length.

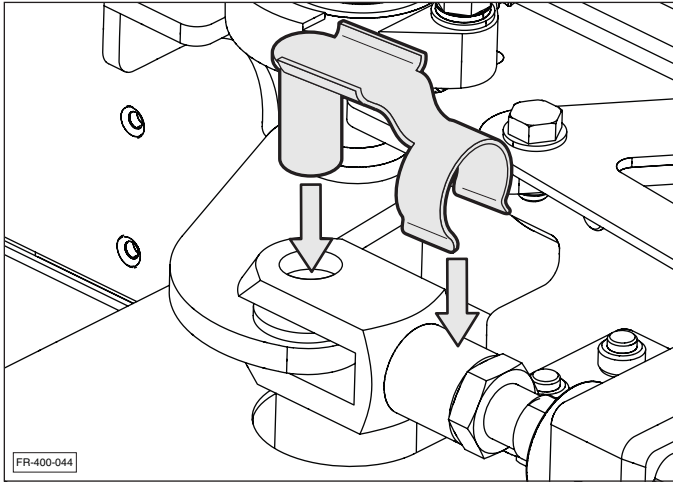

h. Repeat these steps on the forward door panel.

4. Open the main air valve (ON position).

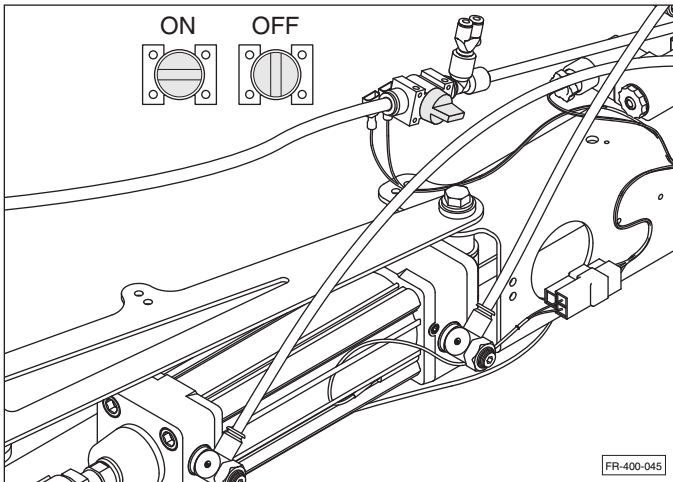

5. Open and close the doors one time. Proceed to the Preloading section for the final adjustments.

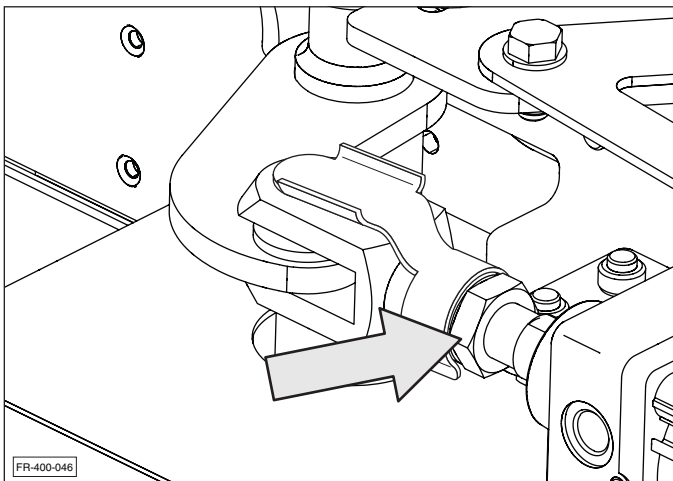

51250142 Door Portal Seal Installation

Install the one piece door portal seal into the door frame.

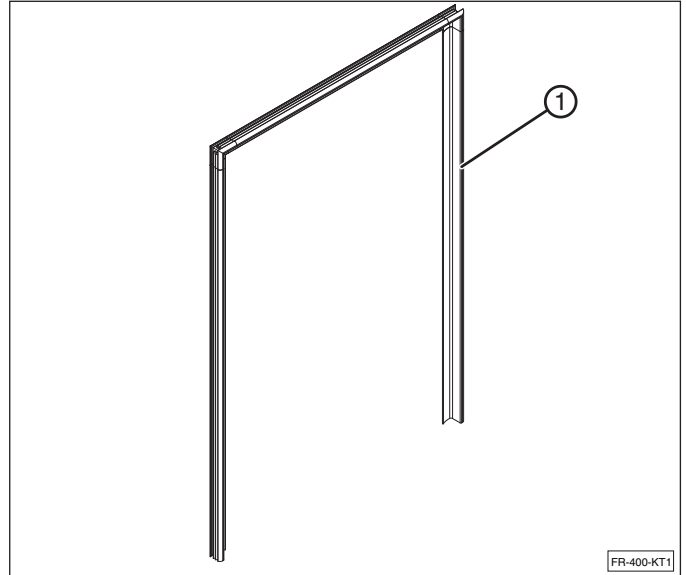

1. Press the tang of the seal into the groove in the door frame in the two upper corners first.

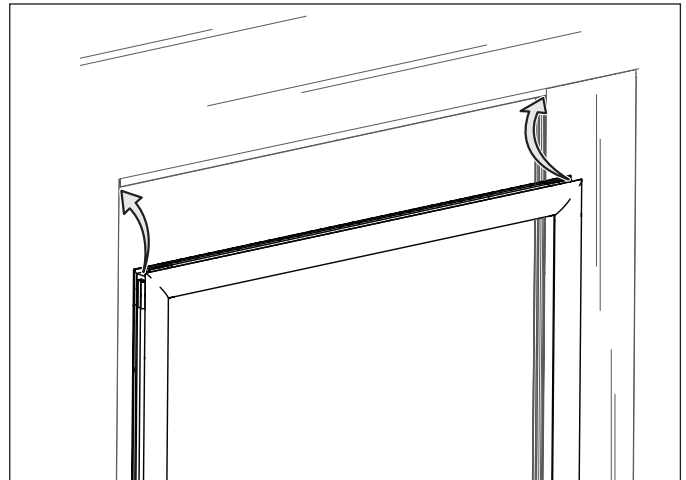

2. Continue pressing the seal into the upper door frame groove towards the middle of the opening. Make sure the tangs of the seal are completely interlocked with the door frame, as shown.

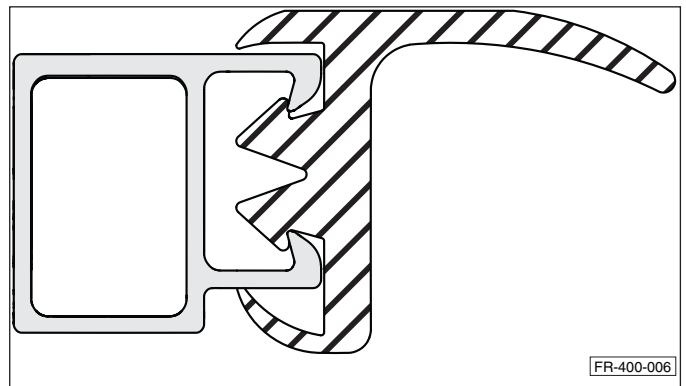

3. Press the seal into the groove on the sides of the frame. Mark and remove the door seal material so the seal will go around the lower pivot bracket assembly.

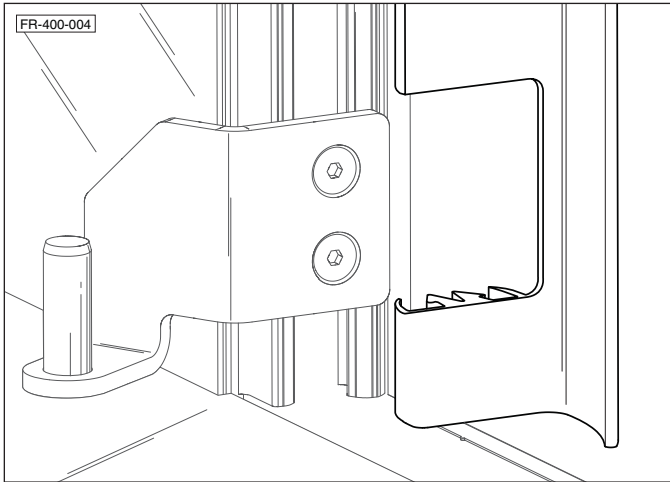

4. Repeat the steps for the opposite side.

Preloading and Door Stop Adjustment

The preloading adjustment is necessary to ensure the doors are securely closed and sealed. Preloading also helps eliminate rattling at higher speeds.

1. Make sure the doors mechanically open and close properly using the driver's door controller (pneumatically actuated).
2. Ensure the doors press against the door seals on the outside of the bus. To obtain a proper seal, it may be necessary to reposition the clevis, but no more than one additional turn.
3. Tighten the lock nut against the clevis to $18 \pm 3 \text{ N}\cdot\text{m}$ ($13 \pm 1 \text{ lb}\cdot\text{ft.}$).
4. Adjust the door open bumper. With the door in the correct open position (90 degrees or other desired angle), adjust the stop against the roller, as shown.

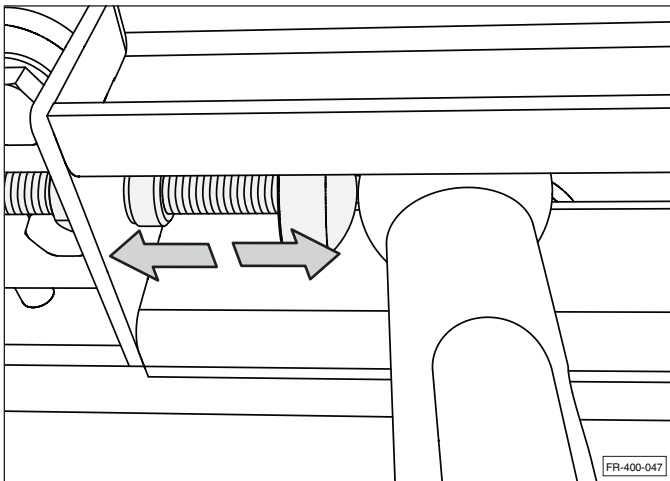

5. Set the door position sensor (reed switch) on the door cylinder towards the front of the bus.

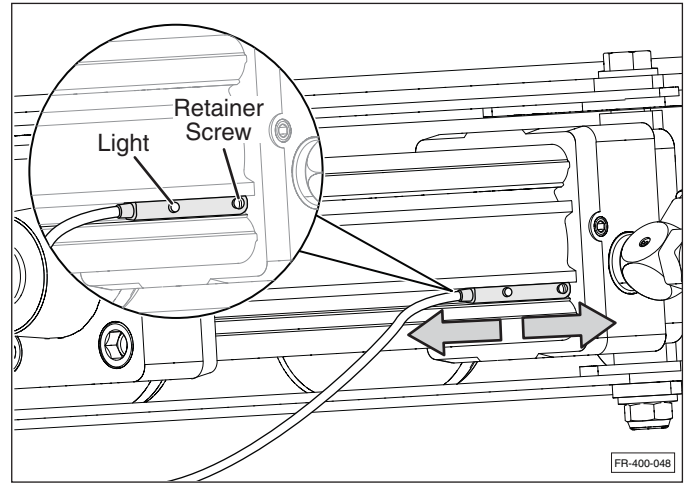

- a. Close the door.
 - b. If necessary, loosen the retaining screw in the upper right-hand reed switch.
 - c. Slide the switch inside the track until the yellow light illuminates.
 - d. Tighten the retaining screw.
6. Set the door position sensors (reed switches) on the door cylinder towards the back of the bus.

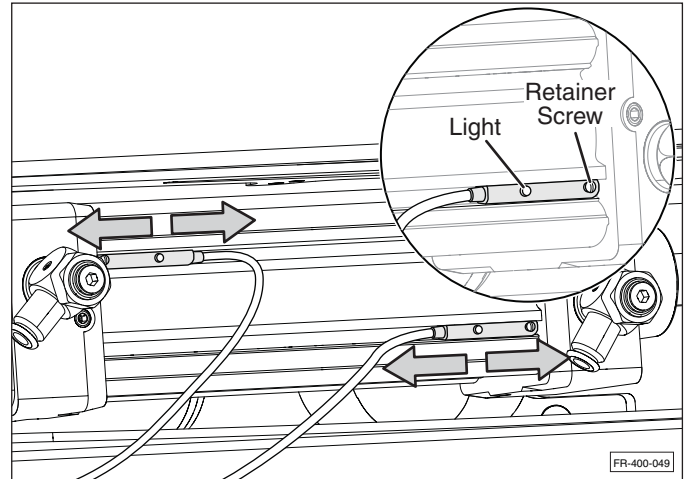

- a. With the door still closed, if necessary, loosen the retaining screw in the upper left-hand reed switch.
- b. Slide the switch inside the track until the yellow light illuminates.
- c. Tighten the retaining screw.
- d. Open the doors.
- e. If necessary, loosen the retaining screw in the lower right-hand reed switch.

- f. Slide the switch inside the track until the yellow light illuminates.
 - g. Tighten the retaining screw.
7. Check and set the opening and closing speed, if necessary. The recommended opening speed is 2 to 3 seconds. The recommended closing speed is 1-1/2 to 3 seconds.

SAFETY INSTRUCTIONS

Adjust the speed control using a 4 mm Allen wrench. An adjustment of 1/8 of a turn will make a significant change in the speed.

NOTICE

Do not overtighten (force) the adjusting screw when turning it in a clockwise direction. Excessive tightening pressure (metal to metal) could damage the cylinder.

- a. Adjust the speed control using a small 4 mm Allen wrench
- b. Use a stop watch and measure the door opening speed of the door towards the front of the bus and adjust it, if necessary. The initial (opening speed) setting is 1-3/4 turns counterclockwise (CCW) from a fully seated position. Turning the screw in the CCW direction increases the speed.

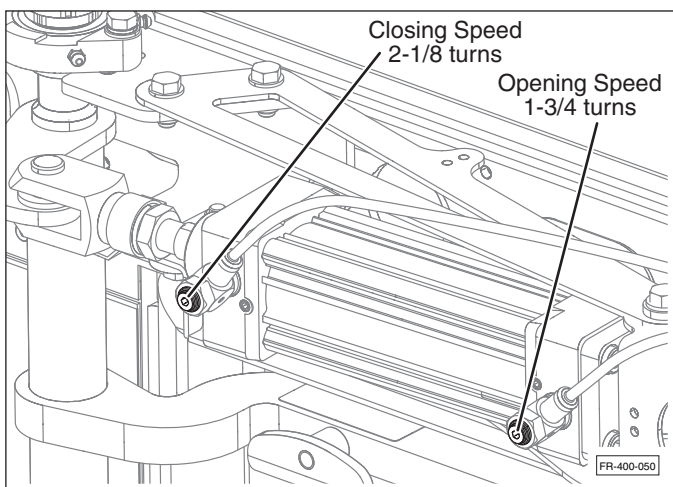

- c. Measure the door closing speed. The initial (closing speed) setting is 2-1/8 turns counterclockwise (CCW) from a fully seated position. Turning the screw in the CCW direction increases the speed.

- d. Measure the door closing speed of the door towards the back of the bus and adjust it, if necessary. The initial (opening speed) setting is 2 turns counterclockwise (CCW) from a fully seated position. Turning the screw in the CCW direction increases the speed.

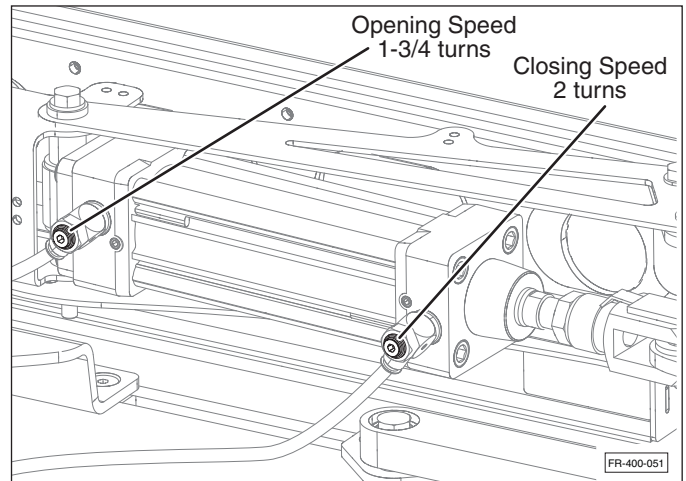

- e. Measure the door closing speed. The initial (closing speed) setting is 1-3/4 turns counterclockwise (CCW) from a fully seated position. Turning the screw in the CCW direction increases the speed.
8. Check and set the amount of cushion effect as the door closes. Cushion is when the door slows as it completely opens or closes.

CAUTION

FLYING OBJECTS HAZARD

Speed and cushion adjustment screws are not captive and may become projectiles if adjusted too far counterclockwise under air pressure. To prevent personal injury, do not place any body part in front of the adjustment port.

- a. The door towards the back of the bus should completely close first, followed by the door closest to the front of the bus.

SAFETY INSTRUCTIONS

Adjust the cushion speed control using a small straight blade screwdriver. A very slight adjustment of the screw will make a significant change in the cushion effect.

NOTICE

The adjustment screw is plastic and can be easily damaged.

- b. Check the door close cushion effect of the door towards the back of the bus and adjust it, if necessary. The initial closing (cushion) setting is 1/4 turn counterclockwise (CCW) from a fully seated position. Turning the screw in the CCW direction decreases the cushion effect.

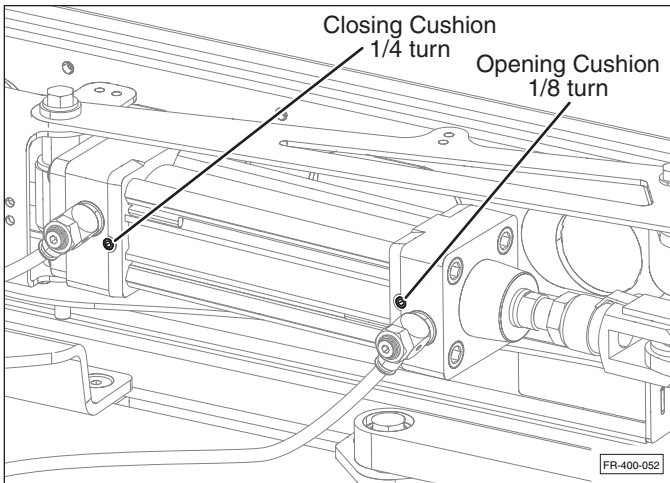

- c. Check the door open cushion effect. The initial opening (cushion) setting is 1/4 turn counterclockwise (CCW) from a fully seated position. Turning the screw in the CCW direction decreases the cushion effect.
- d. Check the door close cushion effect of the door towards the front of the bus and adjust it, if necessary. The initial closing (cushion) setting is 1/4 turn counterclockwise (CCW) from a fully seated position.

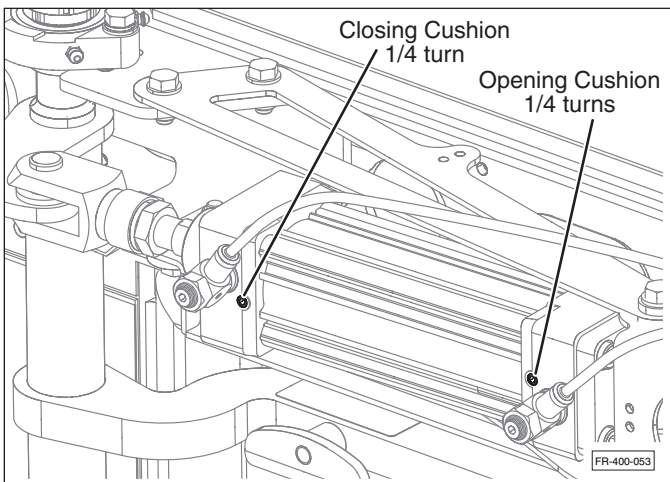

- e. Check the door open cushion effect and adjust, if necessary. The initial opening (cushion) setting is 1/8 turn counterclockwise (CCW) from a fully seated position.

9. Check all connecting hardware and tighten.

Testing the Emergency Door Open Switches

Test the interior and exterior emergency door open switches to make sure they function properly.

WARNING



TRAPPED INDIVIDUAL HAZARD

It is the responsibility of the installer to ensure that the emergency open buttons are installed according to local or national codes. Severe injury and possible death can occur to a rider that is unable to exit the bus.



Vapor Bus International

A Wabtec company