



# CONVENTIONAL

## Owner's Manual



BLUE BIRD

# TABLE OF CONTENTS

---

Introduction .....	3	Transpec Safety Vent .....	30
Foreword .....	4	Stop Arms .....	31
Reporting Safety Defects .....	4	Body Tie Down .....	33
Coach Identification .....	5	Doors .....	34
Inspection .....	5	Vandal Locks .....	36
Switch Panel .....	7	Keeping Your Vehicle Looking New .....	37
Destination Signs .....	7	Heaters .....	38
Seats & Seat Belts .....	8	Windows & Windshields .....	46
Electrical Systems .....	11	Windshield Wipers .....	49
Light Bulb Data .....	14	Lower Side Panel Repair Procedure .....	49
Doran Warning Light Monitor .....	15	Warning Light Door Switch Adjustment.....	50
Circuit Breakers .....	18	Drain Holes .....	50
Body Master Wiring Diagram .....	19	Spare Tire Location & Removal .....	51
Body to Chassis Wiring .....	20	Compressed Natural Gas .....	51
Visibility Equipment Required by FMVSS .....	24	Scheduled Maintenance .....	58
Mirrors & Mirror Adjustment .....	26	Quick Reference Maintenance Charts .....	60
Emergency Equipment .....	28	Body Component Maintenance Chart .....	60, 61
Emergency Exit .....	29	Wheelchair Lift Maintenance Chart .....	61
Wheelchair Lifts .....	30	Index .....	62



# INTRODUCTION

---

Thank you for selecting the Blue Bird Conventional bus body. This body/chassis combination is the result of mass transportation developments, which have been ongoing since 1927. The design and construction of the Conventional bus body reflects Blue Bird's concern for efficient, and above all, Safe Operation.

This manual has been prepared to acquaint you with various aspects of service, maintenance and operation. It explains the various features and controls which should be familiar to the operator before he/she attempts to drive the unit and will help keep your Blue Bird Conventional in top operating condition and help extend its service life.

Your Blue Bird Conventional may have all or some of the equipment described in this manual. Therefore, you may find maintenance data for equipment not installed on your bus. Text, illustrations and specifications in this manual are based on information available at the time of printing. We reserve the right to make changes at any time without notice. You are encouraged to contact your Blue Bird distributor, if additional maintenance information or assistance is needed. For chassis related service and maintenance information contact your local chassis distributor or representative.

The complete line of Blue Bird Service Parts is available from your Blue Bird distributor. The use of original Blue Bird replacement parts and components will help insure that the design features inherent in the Conventional remain for the life of the vehicle.

Proper operation, service and maintenance is important to the safety and reliability of all motor vehicles. The information contained herein is provided as a reference for systems and components that require periodic service. The intervals given are manufacturer's recommendations and should be considered maximum intervals. Actual operating conditions must be considered and maintenance intervals adjusted accordingly. Anytime a system does not perform satisfactorily, corrective service should be performed at once.

Familiarity with automobile operation and controls is not a prerequisite, but is assumed to be common knowledge to all who will be operating this coach. Basically, control and operation of both are the same, but some distinct differences must be recognized before operation of the coach is attempted.

**Remember:** The bus is 8 feet wide without outside mirrors and is 25 to 40 feet long. Therefore, it is 2 feet wider and 2 to 3 times as long as the average automobile. The driver sits in front of the wide track front axle, so the steering has a completely different feel. Acceleration will very likely be slower than that of an automobile. The feel of the brakes may differ from that which is familiar to the new operator. This makes it very important, from a safety standpoint, for him or her to become completely familiar with that function through experience before attempting passenger transit. The operator will observe other differences, but after acquiring basic familiarization and some practical experience, he will find the operation quickly becomes quite natural, comfortable and far from difficult.

**CAUTION: No one should attempt to operate this coach without a thorough knowledge of all instruments and controls, without having had actual driving experience in this or a similar vehicle under supervision, and without having the appropriate license or permit to operate it. Do not drive the coach until the space in front, on the sides and in the rear is unobstructed. Most accidents occur because the operator did not ensure that there was no one in the way before driving.**

**This manual should be read before the operator attempts to drive the unit.**

This manual provides you with the most current maintenance and operation information. We welcome your comments and suggestions regarding this manual. All correspondence should be directed to the Technical Services Department of Blue Bird Body Company, P.O. Box 937, Fort Valley, GA, 31030, Attn: TECHNICAL SERVICES.

## FOREWORD

---

This Operator's Manual provides some general, as well as specific, information regarding safe operation and maintenance of your Blue Bird bus. It does not address all items or situations that may arise and is not a substitute for proper driver and mechanic training. The exercise of care, common sense and good driving and working practices are required for safe operation.

If specific questions or concerns arise that are not adequately addressed in this manual, please contact your Blue Bird distributor. The distributor will answer your questions or put you in contact with the proper factory personnel.

Throughout this guide you will find **CAUTIONS** and **WARNINGS**. **CAUTIONS** are given to prevent you from making an error which could damage the vehicle and possibly cause personal injury. **WARNINGS** remind you to be especially careful to avoid personal injury.

Blue Bird Corporation offers many items as standard and optional equipment to meet state, federal and local specifications and individual customer requirements. Properly selected equipment can help insure reliable and safe transportation of passengers.

Some examples of this safety equipment are: stop arms, crossing guards, warning lights, warning light monitors, mirrors, first aid kits, fire extinguishers, warning reflectors, fuses, directional and brake lights, warning buzzers, vandal locks, emergency exits and seat belts.

It is the driver's responsibility to insure that the safety items are in proper order. Equipment relating to safety should be checked for operation on a daily basis. Safety equipment may vary due to state and federal specifications, and individual customer requirements.

In addition, the driver/operator must insure that the loading area around the bus is clear of pedestrians before stopping and that all unloaded passengers are a safe distance away from the bus before moving.

## REPORTING SAFETY DEFECTS

---

If you believe your vehicle has a safety defect which could cause a crash or could cause injury or death, you should immediately inform the National Highway Traffic Safety Administration (NHTSA) in addition to notifying Blue Bird Corporation.

If NHTSA receives similar complaints, it may open an investigation and, if it finds that a safety defect exists in a group of vehicles, it may order a recall and remedy campaign. However, NHTSA cannot become involved in individual problems between you, your dealer or Blue Bird Corporation.

To contact NHTSA you may either call the Auto Safety Hotline toll free at 1-800-424-9393 (or 366-0123 in Washington, D.C. area), or write to: NHTSA, U.S. Department of Transportation, Washington, D.C. 20590. You can also obtain other information about Motor Vehicle Safety from the hotline.

# COACH IDENTIFICATION

The **Vehicle Certification Plate** certifies that the vehicle conforms to all applicable Federal Motor Vehicle Safety Standards in effect at the date of manufacture. Do not remove or deface this plate. This plate is located over the driver's window.

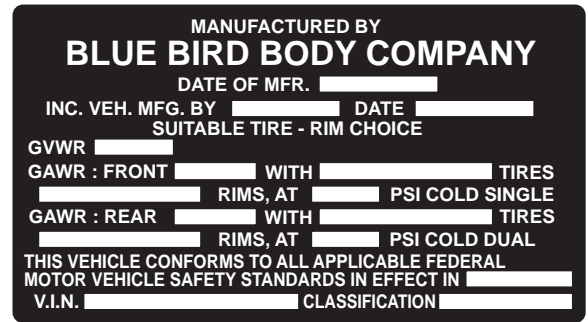

The **Body Serial and Service Number Plate** is located on the front upper inner panel above the windshield. Refer to the data on this plate for registration purposes or for replacement part information.

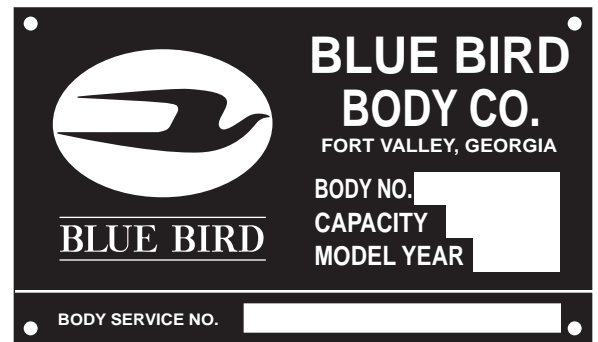

# INSPECTION

## PRIOR TO PLACING THE NEW BUS IN SERVICE, PERFORM THE FOLLOWING:

- Check body tie-down bolts torque.

## DAILY INSPECTION

In order to keep your bus in the best operating condition from the standpoint of safety, convenience, service and operating expense, it is recommended the following inspection procedures be followed on a daily basis. Any malfunctions or defects should be corrected before the next trip. Report needed services to responsible maintenance personnel.

### **Look outside the bus:**

- Windshield, mirrors, front windows, head, tail, directional, and stop lights - wipe clean.
- Exhaust - tailpipe clear?
- Rear emergency door, open and close, check warning buzzer operation.
- Tire pressure and tread, OK? Lug nuts in place?
- Drain air brake tank.
- Look under bus - all clear?
- General outside appearance, clean for school bus identification?
- Mirrors - clean and adjusted?

**Look inside the bus:**

- Seat, floor - housekeeping. Steps and aisle clear?
- Emergency exits open & close, rear door, windows.
- Emergency equipment.
- Fire extinguisher pressure.
- First aid kit.
- Driver's area - windshield, windows clean?
- Mirrors - clean and adjusted?
- Emergency doors/windows unlocked and operate freely?
- Do buzzers activate when exits are not fully latched?

**Starting the engine:**

- Be sure parking brakes are on.
- Put in Neutral.
- With key on, check: Fuel gauge OK? Check brake warning buzzer or light, neutral safety switch.
- Start engine - look, listen for trouble signs, check gauges.

**With the engine running, check (from driver's seat):**

- Mirrors, interior and stepwell lights, service door seal.
- Steering feel OK? Noise?
- Horn, defroster & heater blower, windshield wiper operation.
- Brakes - pedal height & feel, gauge reading OK? Parking brake release, reset.

**Outside checks required before you drive away:**

- Turn signals - right & left, front & rear - clean & flashing?
- Flasher warning lights - front & rear - clean & flashing?
- Stop arm (if used) - clean & working?
- Headlights hi-lo beams.
- Stoplights & taillights - clean & working?
- Hazard flasher working?

**Final check as you move the bus:**

- Seat belt fastened?
- Brakes - Stop & hold?
- Steering feel OK? Unusual noises? Bus under control- tracking straight?
- Brake to a stop. All gauges OK?

**Remember:** Safety on the road also depends on you. Observe weather and road condition and drive accordingly. Be physically and mentally alert. When backing in vicinity of congestion or pedestrians use outside monitor or director. Look around before driving away from where you are parked and observe all traffic rules and regulations.

**WEEKLY INSPECTION**

- Inspect seat cushion attachments for tightness.
- Inspect seat belts and buckles.
- Inspect outside lights for proper operation.

## SWITCH PANEL

1. Pilots - shows when red & amber warning lights are flashing.
2. Heater Switch - controls front heating system.
3. Defrost Switch - controls defrosting output.
4. Circulates air to driver's area or rear.
5. Circulates reheated or fresh air.
6. Right hand heater switches.
7. Underseat heater switches.
8. Manual Warning Light Starter - system may vary on different units.
9. Master Warning Light Starter.
10. Clearance Lights - located on outside of body.
11. Dome Lights.
12. Heater Fan Switches.
13. Accessories - These included lighted destination signs.
14. Left Windshield Wiper.
15. Right Windshield Wiper.
16. Heater Pump - auxiliary water circulating pump for heating system.
17. Panel Illuminating Lights.

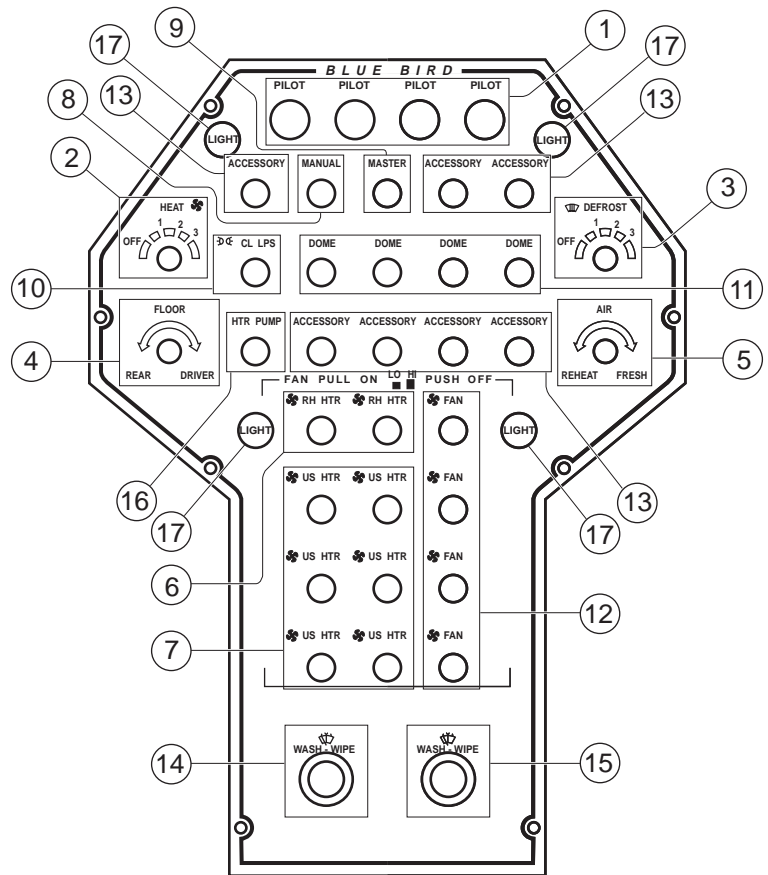

## DESTINATION SIGNS

**Hinged Sign Front** - Mounted on outside of front roof cap with internal control for changing sign. Periodically lubricate hinges and lever assembly with lightweight lubricating oil.

**Hinged Sign Rear** - Mounted on outside of rear roof cap, manually changed from outside. Periodically lubricate hinges with lightweight lubricating oil.

**One Station Lighted Curtain** - Replace bulbs as needed. May occasionally loosen and cause slack in the curtain due to vibration. To tighten curtain, loosen bolts, pull curtain tight, retighten bolts.

**Roller Destination Sign with Lighted Curtain** - Replace bulbs as needed. May occasionally require same adjustment as One Station Sign. Periodically lubricate roller gears with light grease, such as "White Lube," and hinges on access door with lightweight lubricating oil. To change sign, turn crank located on front upper inner panel above windshield to desired destination.

**Two Station Sign** - Front lighted, sign material masonite with lettering on both sides. Lubricate interior door hinge on front upper inner panel with lightweight lubricating oil.

**Lighted "School Bus" Sign** - Back lighted yellow plexiglass sign. Replace bulbs as needed. Lubricate interior door hinge on front upper inner panel with lightweight lubricating oil.

**NOTE:** All maintenance procedures to be done at 6 months or 6,000 mile intervals, whichever occurs first.



# SEATS & SEAT BELTS

## DRIVERS SEAT

The driver's seat may be adjusted fore and aft by pushing forward the release lever located beneath the seat at the center right side, adjusting the seat, and releasing the lever when the seat is in the desired position. To raise or lower the seat, release two height adjustment handles by turning counterclockwise. Raise the seat by lifting it to the desired position. Lower the seat by depressing the height adjustment pedal to release the latch mechanism. Retighten the adjustment handles after the seat is in the desired position.

**WARNING: Do not attempt to adjust seat while vehicle is in motion. Do not adjust height adjustment while sitting in driver's seat. Keep feet and other items away from height adjustment handles and pedals while vehicle is in motion.**

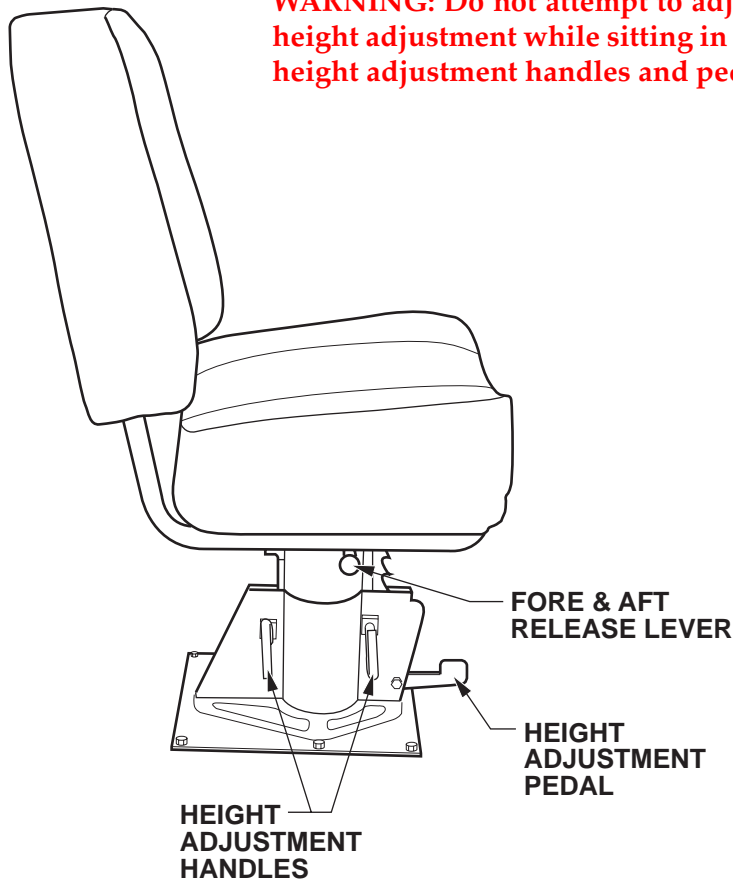

## DRIVER'S SEAT LUBRICATION

Moving parts of the driver's seat require lubrication for ease of operation, as well as, longevity of the seat and prevention of excessive wear.

Currently available white lithium-based grease in an aerosol can, gives excellent coverage, when carefully directed into moving part joints. The very light coating of lubrication provided by aerosol-carried solvent-type solution works very well for penetrating into a joint and cleaning away dirt, but should only be depended on for lubrication, if frequently applied. A common 10W30 or 10W40 motor oil will provide good lubrication.

Remember that all moving part joints, tilt pivots, slide forward/back adjustment and vertical motion pivots (4 total) require lubrication. This should be done every six months or 6,000 miles, whichever occurs first, with a lithium-based grease in aerosol form.

## DRIVER'S SEAT BELT OPERATION

Driver's seat belt should be worn at all times when the vehicle is being driven.

Blue Bird driver's seat belts have automatic locking retractors and are self-adjusting. They also have an anti-cinch device which prevents the belt from uncomfortable tightening as you drive. To use, withdraw ample length of belt from retractor or retractors to allow engagement of buckle halves. Engage buckle halves and allow retractor to withdraw belt to a snug fit. Attempt to pull belt from retractor after it has been withdrawn to assure the automatic locking mechanism is operating properly.

The buckle can be released by pushing button in center of buckle.

## DRIVER'S SEAT BELT WITH SHOULDER HARNESS (IF SO EQUIPPED)

Driver's seat belt should be worn at all times when the vehicle is being driven.

Driver's seat belt shoulder harness is emergency locking; lap belt may be either emergency locking or automatic locking depending on the option chosen. The emergency locking retractor used for all shoulder harnesses and specified lap belts is dual sensitive. Emergency locking retractor engages when the vehicle tips 15 degrees or more or if belt speed exceeds a preset rate. Automatic locking retractors for specified lap belts are self adjusting. If your unit is equipped with the optional adjustable D-ring shoulder harness bracket, adjust D-ring for maximum comfort.

To use, withdraw ample length of belt from retractor or retractors to allow engagement of buckle halves. Engage buckle halves and allow retractor to draw belt to a snug fit.

The buckle is released by pushing the button in center of buckle.

## PASSENGER SEAT BELT OPERATION (IF SO EQUIPPED)

Individual lap belts for passengers are retractable or non-retractable depending on option ordered. Insert the catch into the buckle, test for assurance of latch fit and pull loose end of strap until belt fits snugly across the lower hips. The buckle can be released, by pushing button in center of buckle. The adjustable end can be moved outward on its strap by turning 90 degrees to the strap and pulling.

## SEAT BELT INSPECTION & MAINTENANCE

Inspect seat belts and their attachments on a weekly basis. Check seat belt buckles and adjustability to insure proper operation. If necessary, lubricate buckle with a graphite lubricant. When buckle is found to be inoperable, replace immediately. If there are any defects in the webbing (i.e. torn or frayed), the seat belt must be replaced as soon as possible to ensure passenger safety. Hand wash webbing with warm water and mild soap. Rinse thoroughly and dry in the shade. Do not bleach or redye, because such processing may severely weaken the assembly.

**WARNING: Be sure the lap belt is fitted snugly around the hips, not the waist. Failure to do so may increase the chance of injury in the event of a collision. Do not bleach or redye, because such processing may severely weaken the assembly.**

## SEAT INSPECTION & MAINTENANCE

Blue Bird seats are built to meet Federal Motor Vehicle Safety Standards. In order to provide even safer passenger transportation, the following guidelines should be met.

1. Inspect and retighten seat leg and wall side mounting bolts every 90 days.
2. Inspect and retighten cushion attachments with a Phillips head screwdriver on a weekly basis.
3. Inspect upholstery for cuts and tears every 90 days. If torn, remove upholstery by removing the staples at the bottom front of seat back or bottom of cushion and remove cover. For installation of new cover, reverse this procedure.
4. School bus seats are equipped with a special foam back pad. Should this pad ever become damaged, it should be replaced with an approved replacement part. Aftermarket suppliers do exist and should be checked for compliance with federal standards.

## SEAT CARE AND CLEANING

It is imperative that the interior of the bus be kept clean and seats are an important part of this maintenance. Regular cleaning and care will prolong the life of the seats and improve the general appearance.

**Everyday dirt and soil** - Most everyday soil and dirt may be removed with a soap and water solution. If the stain is persistent, a stiff bristle brush may be used. Fabric covered seats should be rinsed with clean water after stain is removed.

**Paint, tar and asphalt** - Remove stain immediately using a damp cloth and kerosene. Rub the stain gently, using small strokes. Rinse thoroughly. **NOTE:** This type of stain may become permanent if not cleaned immediately.

**Nail polish and lacquer-based stains** - Soak up as much as possible with dry cloth immediately. Any remaining stain may be removed with a nonflammable cleaning fluid such as "Tuff Stuff" or "Armorall" cleanser. Rinse thoroughly with clean water.

**Gum, grease and shoe polish** - Remove as much as possible immediately. Shoe polish if left for any length of time will permanently stain. Clean any remaining stain with "Tuff Stuff" or "Armorall" cleanser.

**Ink** - Remove stain immediately using a damp cloth and alcohol.

## SEAT CUSHION REMOVAL & INSTALLATION - DOT SEATS

**WARNING: If seat cushions are removed for maintenance, they must be reinstalled using the following instructions. Failure to comply with these instructions could result in injury from unattached seat cushions in the event of an accident.**

### REMOVAL

1. Loosen the two front swivel type clamps at the front underside of the cushion with a phillips-tip screwdriver. **Caution: Do not remove clamps.**
2. Rotate the swivel clamps so as to clear the front retaining channel frame.
3. Lift the forward edge of cushion 2 to 3 inches and pull cushion forward to remove.

### INSTALLATION

1. Place the rear edge of cushion down on the base portion of the seat frame. Lifting the forward edge 2 to 3 inches, slide the cushion to the rear to engage the positive type clamp into the rear retaining channel.
2. Lower the forward edge to the frame, making sure the swivel clamps are inside the frame and the positive type clamps are secure on the rear retaining channel.
3. Rotate the swivel clamp to engage the forward retaining channel frame.
4. Tighten with phillips-tip screwdriver until clamps do not rotate.

## SEAT CUSHION REMOVAL & INSTALLATION - DOT SEAT BELT SEATS

### REMOVAL

1. Loosen the two front swivel-type clamps at the front underside of the cushion with a phillips-tip screwdriver. **Caution: Do not remove clamps.**
2. Rotate the swivel clamp located at the rear underside of seat cushion.
3. While lifting the rear edge of the cushion, pull the cushion to the rear and remove.

### INSTALLATION

1. Place the forward edge of the cushion 2 inches to the rear of the front retaining channel. Slide the cushion forward, engaging the positive clamps onto the forward retaining channel.
2. Lower the rear edge to the frame and rotate the swivel clamps so they engage the square tube crossmember.
3. Tighten screws in front and rear clamps with phillips-tip screwdriver until clamps do not rotate.

## TRACK MOUNTED PASSENGER SEATS

If your bus is equipped track mounted passenger seats and you relocate the seats or remove the seats to accommodate wheelchairs, you must follow rules of spacing and placement to comply with FMVSS 222 "School Bus Passenger Seating and Crash Protection" and FMVSS 217 "Bus Window Retention and Release".

The decal (as shown) which gives these rules is installed on the interior body panel above the windshield.

All passenger seats must have a seat or barrier in front of it to provide compartmentalization required by Federal Motor Vehicle Safety Standards. As you reconfigure your bus, you may need additional barriers. Barriers are available from Blue Bird Body Company Part Sales.

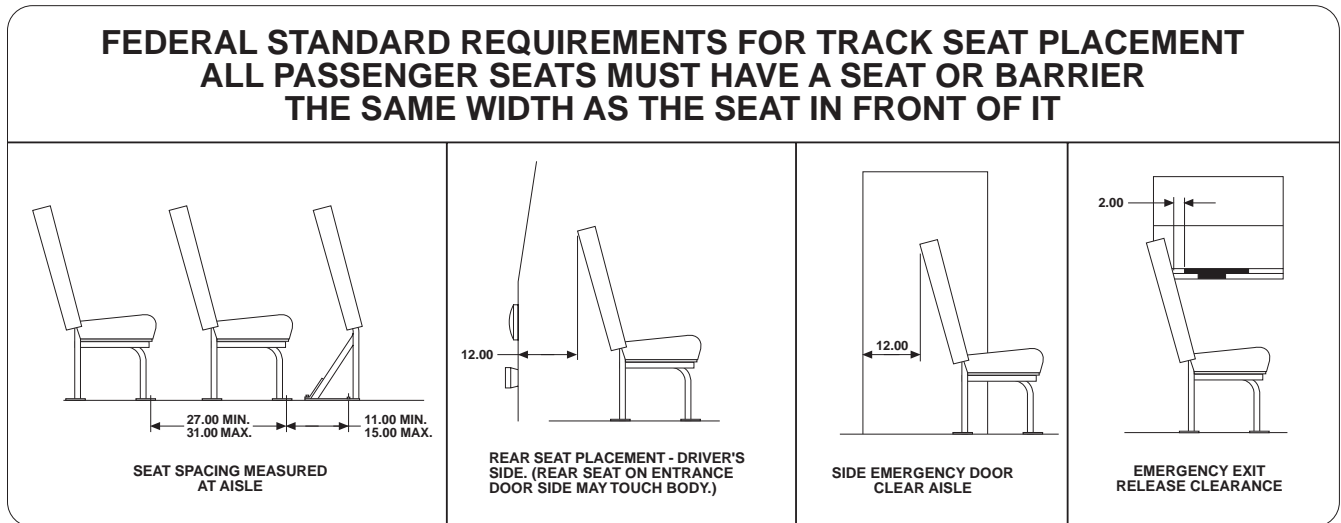

## ELECTRICAL SYSTEMS

The following guidelines must be followed when doing any work on vehicle electrical components or wiring.

1. Before beginning any electrical work, disconnect all batteries. Always remove all battery ground straps first and replace last to prevent accidental arcing.
2. Use only proper gauge wiring with high temperature insulation, such as, chemically cross-linked polyethylene, which meets SAE J-1128 (150 Degree Celsius).
3. Be certain any added circuit is protected by the use of a fuse or circuit breaker.
4. Any push-on terminal must be insulated.
5. When installing or replacing any wiring (other than ground straps), observe the following:
  - A. Always use clamps to secure wires away from any sharp metal edges or moving components.
  - B. Support wires at least every 30 inches with insulated clamps.
  - C. Where wiring is connected to moving component such as the engine, provide an adequate slack loop to allow for motion in all directions. Clamp at both sides of loop.
  - D. Be certain there is sufficient length in wires so no wires are pulled in tension.
  - E. Wires should be secured to remain four inches from exhaust pipes, manifolds or turbochargers unless components are shielded.
  - F. Use rubber grommets whenever wires must pass through holes.
  - G. Cover all full time hot or accessory and ignition hot wires with approved loom.
  - H. Avoid routing wires in contact with fuel lines or plastic components.

6. Always be sure ground straps are replaced when any work is done on engine components. The alternator must have at least a six (6) gauge strap. The engine must have one strap, engine block and transmission. (Use bolt that mounts transmission to rear face of engine block.) Allow slack loop for engine motion. Use external star tooth washer between cable and frame.
7. Do not "splice" into existing wires, instead route wire full length to appropriate source.
8. If accessories must be added, relays may be required; check installation instructions thoroughly. Use bank of circuit breakers in the electrical panel unless the accessory must be on during cranking, in which case the "hot bar" should be used.
9. Always use insulated rubber boots over hot six (6) gauge wiring on alternator, ammeter shunt or junction blocks.

**Quick Reference**

**Wiring Circuit Color Code Major Circuits**

FUNCTION	COLOR
Left Rear Directional Light	Yellow
Right Rear Directional Light	Dark Green
Stoplights	Red
Back-up Lights	Blue
Taillights	Brown
Ground	White
Ignition Feed, Primary Feed	Black

Refer to the master wiring diagram for wire colors for other circuits.

**NORMAL CURRENT USAGE**

**STANDARD EQUIPMENT**

**Constant Load**

Item	No. Items	Amps
Cluster Lamps	6	4.14
Clearance Lamps	4	2.76
Intermediate Side Mkr.	2	1.38
*Tail Lamp	2	1.18
Ignition	1	2.50
Instrument Panel		1.00
Headlamps (Dual Low Beam)	2	8.40
Parking Lamps	2	1.18
^90-FC & MB Heater	1	27.00
^90-Conv. Heater	1	31.50

**Intermittent Load**

Item	No. Items	Amps
Stepwell Light	1	.44
*Stop Lamp	2	4.20
Dome Lamps (each)	Varies	.58 ea.
Back-up Lamps	2	4.20
Electric Wipers	2	8.00
*Combined Stop and Tail Lamp		
^Use Applicable Heater		

**OPTIONAL EQUIPMENT**

**Note:** To figure current draw, add constant load and 35% of intermittent load.

**Policy**

1. Warning light options include lights, standard flasher and pilot light. If optional flasher unit is desired, add current draw of that option.
2. Directional light options include lights and standard thermal flasher.

**Constant Load**

Item	Opt. No.	Amps
Auxiliary Fan	0525	3.0
	0530	6.0
	0532,0546	3.0
Exhaust Fan	0552	2.0
Heater	1145	31.5
	1153	9.0
	1230	2.5
	1325,1330	4.5
	1336,1342	9.0
Heater Pump	1416	6.75
Clearance Light	1576	2.16
	1581	1.08
	1591	.54
Cluster Light	1642	1.62
Door Light	1878-01	.59
	1878-02	1.18
	1878-03	1.77
P.A. System	2525,6404	.40
Radio	2532,2535	.60
Radio & P.A.	2534,6406	1.00
Dest. Sign	3052,3053	4.06
Dest. Sign (Roll)	3059	4.06
School Bus Sign	3064	4.06
Frnt. & Rear School Bus Sign	3065	8.12

**Intermittent Load**

Item	Opt. No	Amps
Directional Lights	1676,1681,1686	2.10
	1697,1701,1707,	
	1719,1723,	
	1727,1731,	
	1740	.27
	1788,1790	
	1796,1798	4.20
	1820	.27
Dome Lights	1825,1828,	
	1831**,1832**,	
(**Per Lamp)	1840	.58
7" Stop Lights	1931	4.79
	1940	4.20
	6728	4.20
Warning Lights	1987,1990,1992,	
	2013,2016,2017	12.50
	2025	10.00
Solenoid Switch	2130,2131	.75
DOT Buzzer	3001-01	1.00
	3001-02	1.50
	3001-03	2.00
Emergency Door	3020	.94
Pilot Light & Buzzer	3025	.94
Chime System	3040	1.00
Stop Arm w/Lights	3135,3148,	
	3155,3162,	1.80
Stop Arms Dual w/Lights	3149,	3.60
Pushout Windows w/Buzzer	3343	.50
Sanders	4015,4475	1.50
56" Wheelchair Lift	0467	48.00
35" Wheelchair Lift	0469	48.00
42" Wheelchair Lift	0465,0466	90.00

**BODY WIRING IDENTIFICATION**

4 GA Blk/Red w/o SAE	11	14 GA Brown	35	14 GA Yellow	73
4 GA Blk/Wht w/o SAE	12	14 GA Brown/Tan	37	14 GA Yellow/Black	74
4 GA Blk/SAE Stamp	13	14 GA Brown/White	41	14 GA Yellow/Green	75
6 GA Black	14	14 GA Green	42	16 GA Black	111
6 GA Red	15	14 GA Green/Black	43	16 GA Black/White	112
6 GA White	17	14 GA Green/White	44	16 GA Brown	113
8 GA Black	21	14 GA Lt. Blue	45	16 GA Brown/Orange	114
8 GA Red	22	14 GA Orange/Black	47	16 GA Gray	115
10 GA Black	23	14 GA Orange/Brown	51	16 GA Green/Black	117
10 GA Black/Yellow	24	14 GA Purple	52	16 GA Lt. Blue	121
10 GA Red	25	14 GA Red	53	16 GA Orange	122
10 GA Yellow	27	14 GA Red/White	54	16 GA Pink	123
10 GA Yellow/Black	1	14 GA Tan/Black	55	16 GA Red/Black	124
14 GA Black	32	14 GA White	57	16 GA Tan	125
14 GA Black/Yellow	3	14 GA White/Black	71	16 GA Tan/Orange	127
14 GA Blue/Black	34	14 GA White/Orange	72	16 Ga White/Green	131

# LIGHT BULB DATA

---

Lamp Description	Trade Name	Trade No.	Color	Bulb No.
<b><u>INTERIOR LIGHTS</u></b>				
Dome	Weldon	8005	(Standard)	89
	Weldon	8010	(Deluxe)	93
Stepwell	Arrow	35		67
Emerg. Door Light	Weldon	8025		67
Switch Panel Pilots	Cole Hersee	PL19		53
	Dial	41204-1211		68
Switch Panel Illum.		1791300		53
<b><u>EXTERIOR LIGHTS</u></b>				
Directional	KD	772-9105		1156
	Weldon	1010 Series	Red & Amber Plain & w / Arrow	1156
	Signal Stat	1604		1156
Warning Light	Weldon	1020-Series	Red & Amber	4636
Cluster & Marker	Weldon	5050	Amber & Red	409
	Peterson	122	Amber & Red	194
Side Directional	Peterson	122		194
	Arrow	059-9900021CP		1073
Stop-Tail/Tag	Dominion	70-6128-71		1157
	Signal Stat	2103		1157
Back-UP	KD	854-5301		1156
	Weldon	7-1010-1		1156
Stop	Weldon	1010	Red	1156
	Arrow	438		1157
	Signal Stat	1605		1156
	KD	772-9105		1156
Destination Sign				89
School Bus Sign				TS93



# DORAN WARNING LIGHT MONITOR

The Doran monitor is a current-monitoring device; therefore, if current is flowing through one of the bus lamp circuits, the monitor senses this and lights the corresponding monitor bulb. If the bus lamp burns out, current ceases and the corresponding monitor bulb goes out indicating a fault. (See schematic illustration Page 18 showing A Typical Monitor Circuit).

The Doran monitor is a reliable, long-life device, but as with most electrical instruments, it can be overheated and damaged if an overload occurs in a bus light. Such overloads can exist if a bus light circuit becomes shorted, forcing current through a coil in the monitor which exceeds its rated capacity. Short circuits can occur if improper connections are made during installations, during bus repairs, etc. If the monitor has an optional thermistor overload protection, the tail light circuits are overload protected (thermistors are located on the bottom of the component side of the P.C. Board).

This repair instruction is intended to assist qualified repair personnel to diagnose, remove, repair and reinstall monitors, which have become inoperative due to a variety of conditions.

## REPAIR PROCEDURE

**NOTE:** Field repair is not intended for monitors covered by Blue Bird Body Company warranty. Inoperative monitors under warranty should be returned to Blue Bird Body Company for repair or replacement under the terms and conditions of warranty for electrical parts.

- Step 1: MOST IMPORTANT! Carefully note and record exactly which monitor lamps are not operating properly. Include this information on a tag to be attached to the monitor after removal from the bus panel.
- Step 2: Disconnect bus battery.
- Step 3: Remove mounting screws, which attach the monitor to the bus panel, being careful not to accidentally pull any connecting wires loose.
- Step 4: Remove one connecting wire at a time from monitor terminals, tagging EACH WIRE with the terminal number shown on the monitor.
- Step 5: If a spare monitor is to be installed at this point, record the monitor serial number for your future reference. The number is shown on both the protective fiberboard back plate and on the monitor printed circuit board.
- Step 6: With the monitor removed from the bus and to a repair bench, remove the four nuts to remove the monitor PC board from the face plate. Pull the protective fiberboard backing from the terminals, being careful not to bend or tear it; retain for later use.
- Step 7: Locate the components to be replaced by referring to Diagram of Coils and Reed Switches on Page 16. Locate the solder points for these components.
- Step 8: Replace the inoperative coil/reed switch assembly as follows:
  - a. With wire clippers cut the reed switch leads (2) and the coil leads (2) as close to the board surface, as possible. (If a tail lamp monitor is to be replaced, pull the protective shield loose and retain for reuse later).
  - b. With soldering iron, CAREFULLY melt-out the remaining coil and reed switch leads from the solder side of the board, pulling gently on the leads with tweezers. With the lead stubs removed, touch the holds in the PC board with soldering iron to "clear" them for replacement lead insertion.
  - c. Insert replacement coil and reed switch leads, guiding them into proper holes with index finger and thumb. Hold coil snug to the board while leads are bent over the solder side of the board. It is recommended that excess leads not be clipped until after soldering is completed. This will help to minimize shock or vibration on the reed switch, when leads are later trimmed. (Reed switches are encased in a fragile envelope and should be handled carefully to avoid chipping of envelope or distortion of leads).



- d. Place a bead of solder on the remaining lead ends, being careful not to interfere with other nearby solder points or PC paths.

Step 9: If a tail lamp has been replaced, clean the original sealant from the protective shields and reinstall with new Silicone rubber sealant as recommended.

Step 10: Visually examine all other components, leads, PC paths and LED's for any remaining problems to be corrected. Reinstall monitor in bus, making sure battery is disconnected and that wires are reconnected to the monitor in the same order as shown in chart on page 18.

If additional instructions are needed after following the above procedure, contact Blue Bird Body Company.

## **DIAGNOSIS**

### **Condition A**

If ALL lights on the monitor are inoperative, even though the exterior lights on the bus operate properly, and all connections are still intact, the causes may be:

1. Overloading or physical damage has burnt or broken a path on the printed circuit board. (It is not considered practical to attempt field repair of printed circuit board paths, and a replacement monitor is recommended).

### **Condition B:**

If a particular light is inoperative, even though the corresponding exterior bus lamp operates properly, and all connections to the monitor are intact, the cause may be:

1. A burned-out coil or inoperative reed switch. Burned-out coils can usually be visually detected by a blackened appearance, when the monitor is removed from the bus. If a burned-out coil has not scorched the board and distorted a PC path, a replacement coil/reed switch kit can be installed. (Available through your usual Blue Bird service parts source).
2. A loose connection in one or both leads of the light emitting diode (LED) on the monitor. LED's seldom fail unless they are installed with incorrect polarity or have suffered physical damage. The LED recessed design of face plate protects against normal usage. (LED's CAN be ruined by Ohm meters, and care must be taken to avoid the use of such meters).

The cause of an inoperative LED will generally be found in monitor and bus circuits other than at the LED; however, if an LED itself is known to be inoperative, contact your usual Blue Bird service parts source for special handling of replacement LED's.

### **Condition C:**

If a monitor light stays on even when the exterior light of the bus is turned off, the reed switch located inside of the monitor coil is not operating properly. This can be repaired in the field by replacing the coil and reed switch (available in a preassembled unit from Blue Bird Body Company) - see Condition B, Item 1, above.

**Condition D:**

If the tail light monitor and exterior tail lights fail to operate, the cause may be:

1. Tail light bulbs may need to be replaced.
2. An over current situation. In this case, the thermistor has protected the entire circuit. Remove power from the circuit and monitor, repair over current and reconnect.

Some causes of over current:

- A. Dead short,
- B. Wrong tail light bulb, and
- C. Parallel wiring of additional tail lights.

**TOOLS AND SUPPLIES REQUIRED FOR REPAIR**

- Hand tools as required to remove mounting screws at bus panel.
- Tags suitable for use in marking connecting wires, and also for recording the monitor problem.
- A 30 or 40 watt soldering iron for electronic repair (do not use a 100-watt “shop” iron).
- Small wire clippers.
- Pointed tweezers (Claus #225, or equivalent).
- 60/40 resin core solder, .031 or .062 thick (Kester “44” or equivalent).
- Replacement coil/reed switch kits. (Note that coils for bus warning lights are 10-turn coils; those for tail lamps are 50-turn coils, and those for back-up lights, turn signals, and stop lights are all 16-turn coils. The proper coil MUST be used in replacement.

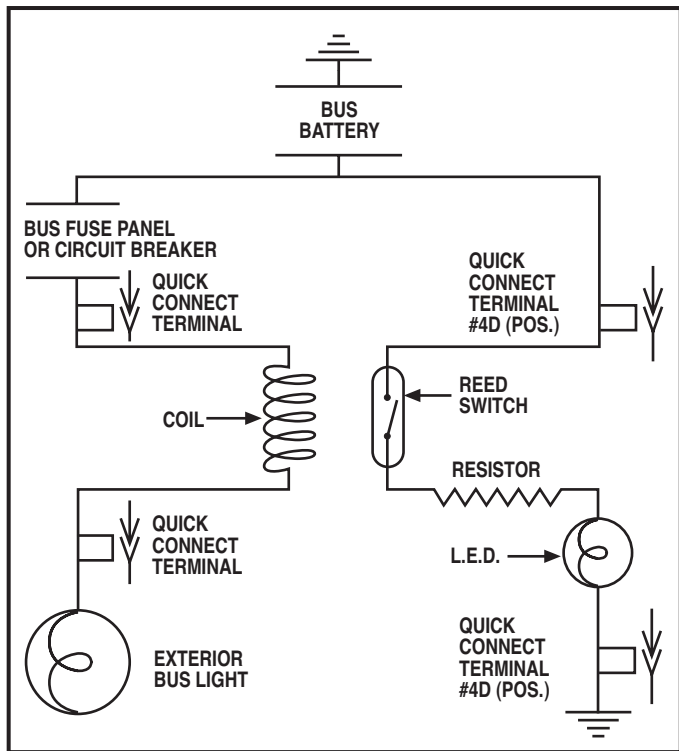

DORAN EXTERIOR LIGHT MONITOR  
(A Typical Circuit)

Connection	Lamp Function	Model:	Monitor				
			A	B	C	D	E
4A	RED WARNING LAMP RIGHT INPUT		X	X	X	X	
1A	RED WARNING LAMP RIGHT FRONT OUTPUT		X	X	X	X	
6A	RED WARNING LAMP RIGHT REAR OUTPUT		X	X	X	X	
2A	AMBER WARNING LAMP RIGHT INPUT			X	X		
3A	AMBER WARNING LAMP RIGHT FRONT OUTPUT			X	X		
5A	AMBER WARNING LAMP RIGHT REAR OUTPUT			X	X		
4B	RED WARNING LAMP LEFT INPUT		X	X	X	X	
1B	RED WARNING LAMP LEFT FRONT OUTPUT		X	X	X	X	
6B	RED WARNING LAMP LEFT REAR OUTPUT		X	X	X	X	
2B	AMBER WARNING LAMP LEFT INPUT			X	X		
3B	AMBER WARNING LAMP FRONT			X	X		
5B	AMBER WARNING LAMP LEFT REAR OUTPUT			X	X		
3C	TURN SIGNAL LAMP RIGHT REAR OUTPUT				X	X	X
4C	TURN SIGNAL LAMP RIGHT REAR INPUT				X	X	X
2D	TURN SIGNAL LAMP LEFT REAR INPUT				X	X	X
3D	TURN SIGNAL LAMP LEFT REAR OUTPUT				X	X	X
1C	STOP LAMP - INPUT				X	X	X
2C	STOP LAMP RIGHT - OUTPUT				X	X	X
1D	STOP LAMP LEFT - OUTPUT				X	X	X
7D	TAIL LAMP - INPUT				X	X	X
7C	TAIL LAMP RIGHT - OUTPUT				X	X	X
8D	TAIL LAMP LEFT - OUTPUT				X	X	X
6C	BACK-UP LAMP - INPUT				X	X	X
8C	BACK-UP LAMP RIGHT OUTPUT				X	X	X
5D	BACK-UP LEFT - OUTPUT				X	X	X
CONNECT LAST:							
4D	12 V DC POWER		X	X	X	X	X
6D	GROUND		X	X	X	X	X
5C	OPEN		X	X	X	X	X

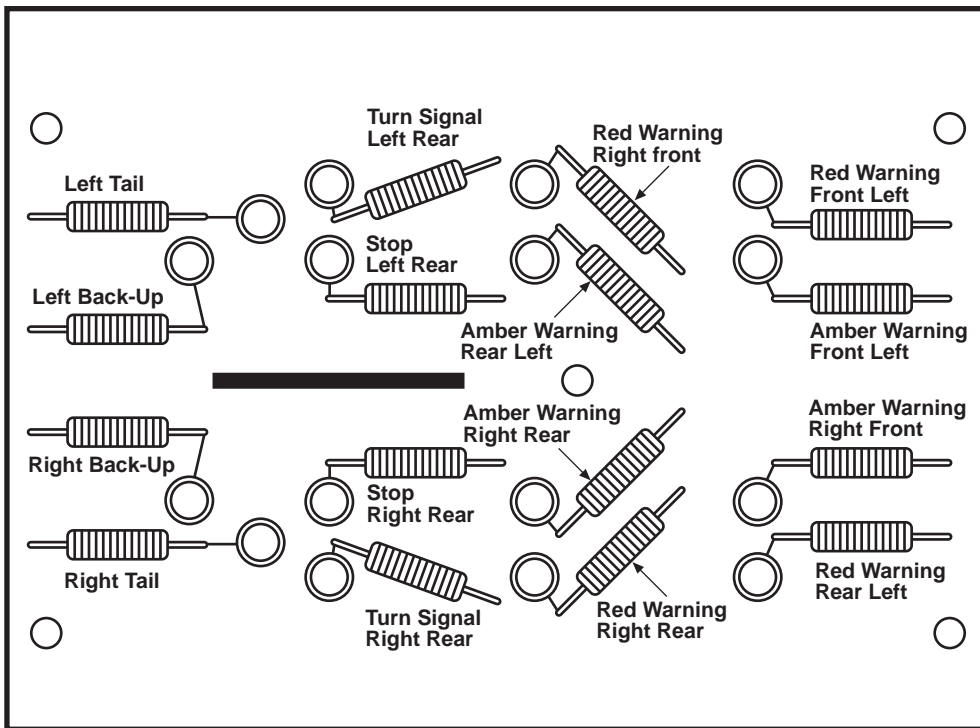

DORAN EXTERIOR LIGHT MONITOR  
 Diagram of Coils and Reed Switches with Indication of the L.E.D.'s they Control

## CIRCUIT BREAKERS

Blue Bird uses circuit breakers instead of fuses. The circuit breakers are a quick resetting type. The advantage of this type circuit safety device is that no replacement (as with fuses) is required. When the breaker opens a circuit, follow standard electrical troubleshooting procedures within the circuit to determine the cause of overload. Exposed wires and electrical shorts are the most common causes. Breakers can be accessed by removing the access and switch panel as highlighted in the photo below.



# **BODY MASTER WIRING DIAGRAM**

---

# BODY TO CHASSIS WIRING

GMCV

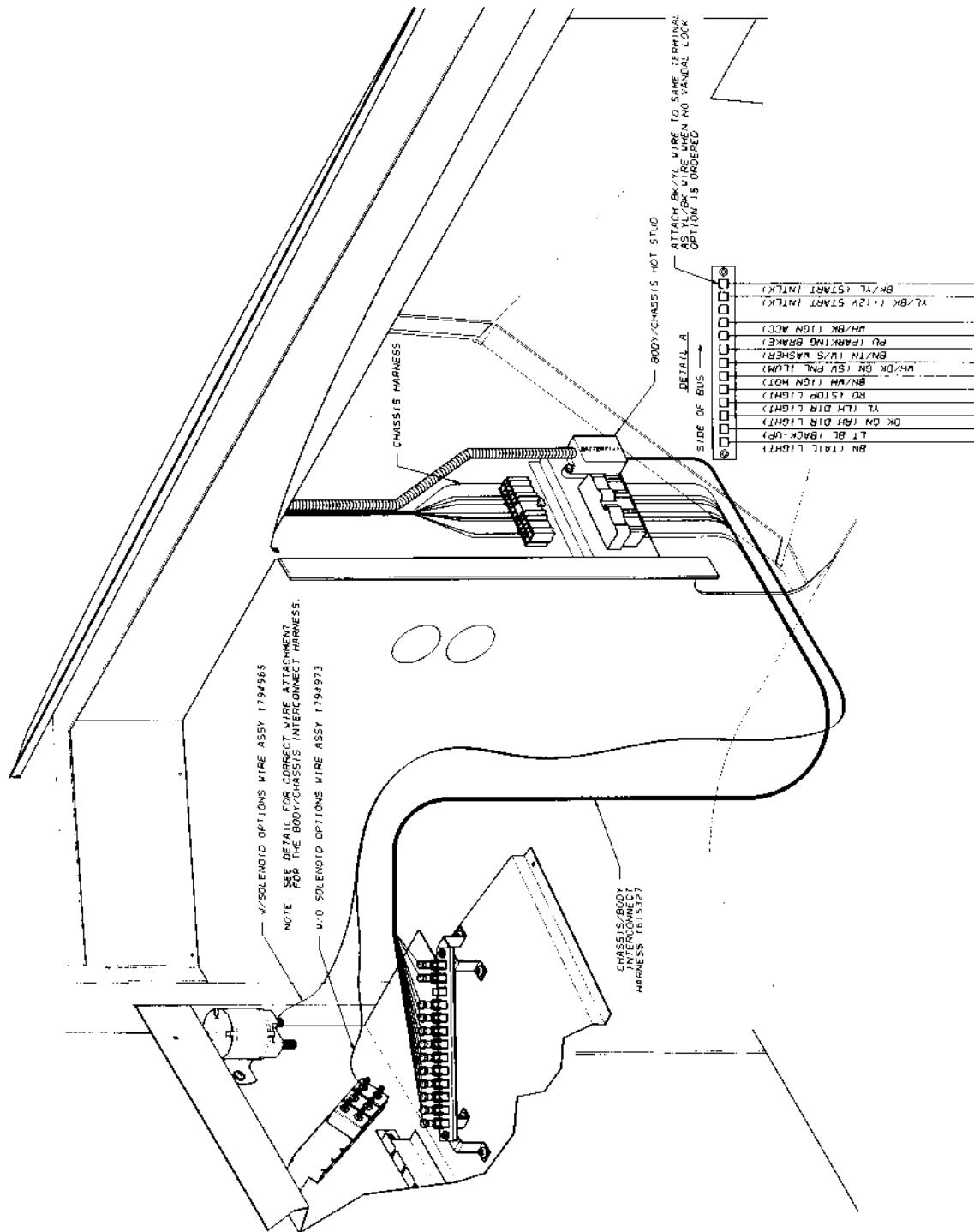

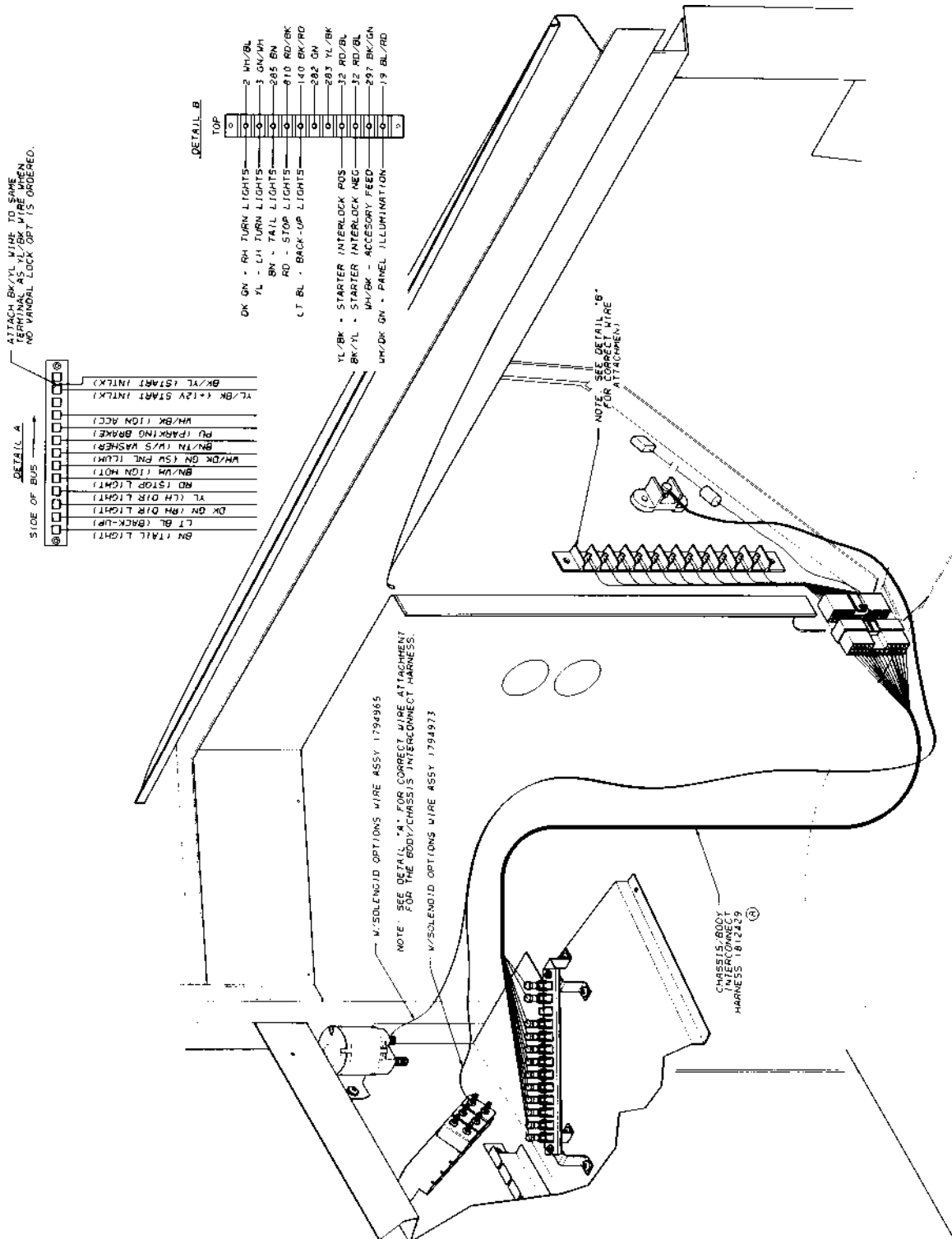

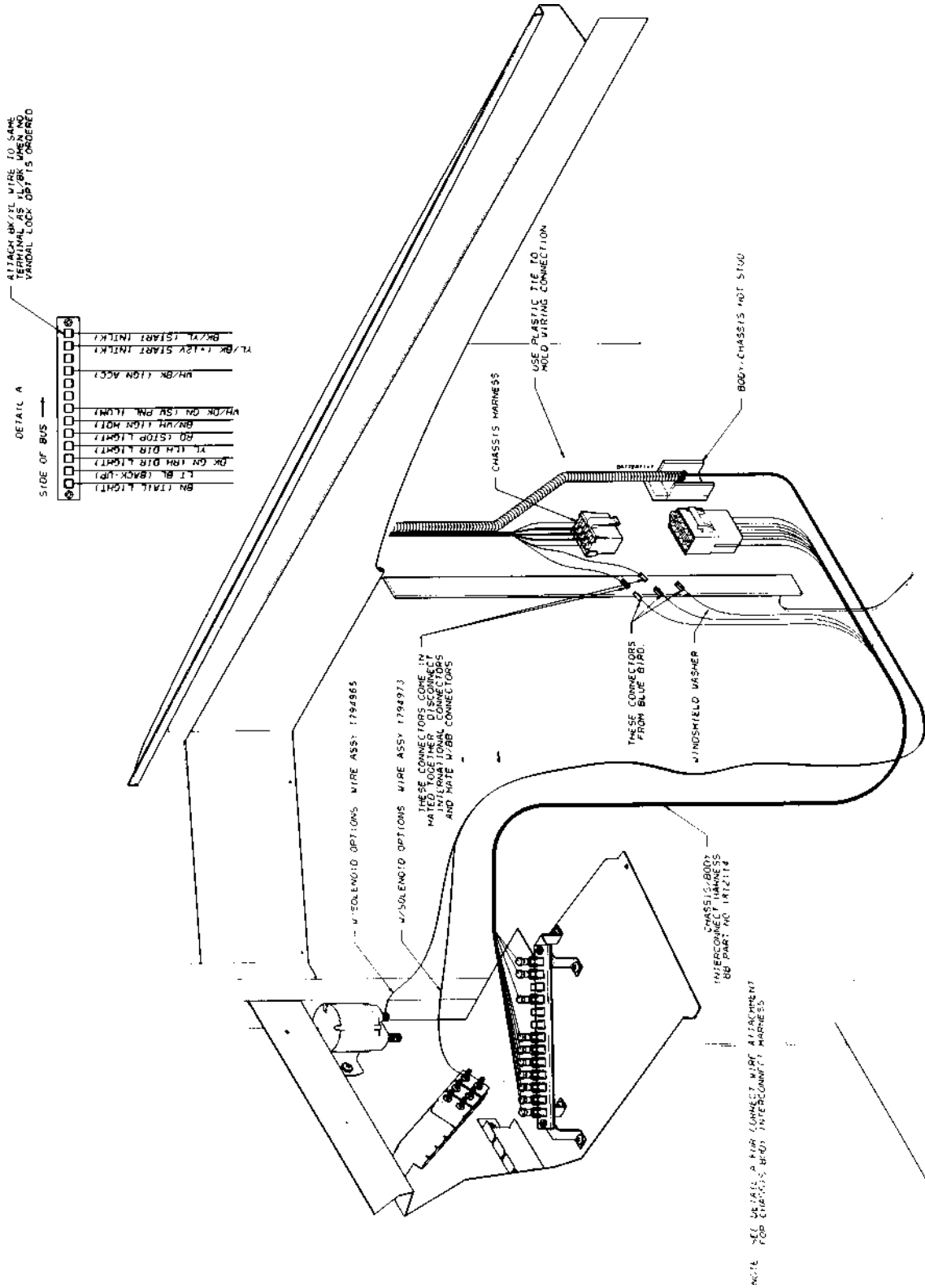

STANDARD WIRE TO BODY  
TRAINING AND TANK WIRING  
VARIABLE LOCK CIRCUITS

WIRE NO.	DESCRIPTION	WIRE NO.	DESCRIPTION
1	12VDC	10	12VDC
2	12VDC	11	12VDC
3	12VDC	12	12VDC
4	12VDC	13	12VDC
5	12VDC	14	12VDC
6	12VDC	15	12VDC
7	12VDC	16	12VDC
8	12VDC	17	12VDC
9	12VDC	18	12VDC
19	12VDC	19	12VDC
20	12VDC	20	12VDC
21	12VDC	21	12VDC
22	12VDC	22	12VDC
23	12VDC	23	12VDC
24	12VDC	24	12VDC
25	12VDC	25	12VDC
26	12VDC	26	12VDC
27	12VDC	27	12VDC
28	12VDC	28	12VDC
29	12VDC	29	12VDC
30	12VDC	30	12VDC
31	12VDC	31	12VDC
32	12VDC	32	12VDC
33	12VDC	33	12VDC
34	12VDC	34	12VDC
35	12VDC	35	12VDC
36	12VDC	36	12VDC
37	12VDC	37	12VDC
38	12VDC	38	12VDC
39	12VDC	39	12VDC
40	12VDC	40	12VDC
41	12VDC	41	12VDC
42	12VDC	42	12VDC
43	12VDC	43	12VDC
44	12VDC	44	12VDC
45	12VDC	45	12VDC
46	12VDC	46	12VDC
47	12VDC	47	12VDC
48	12VDC	48	12VDC
49	12VDC	49	12VDC
50	12VDC	50	12VDC

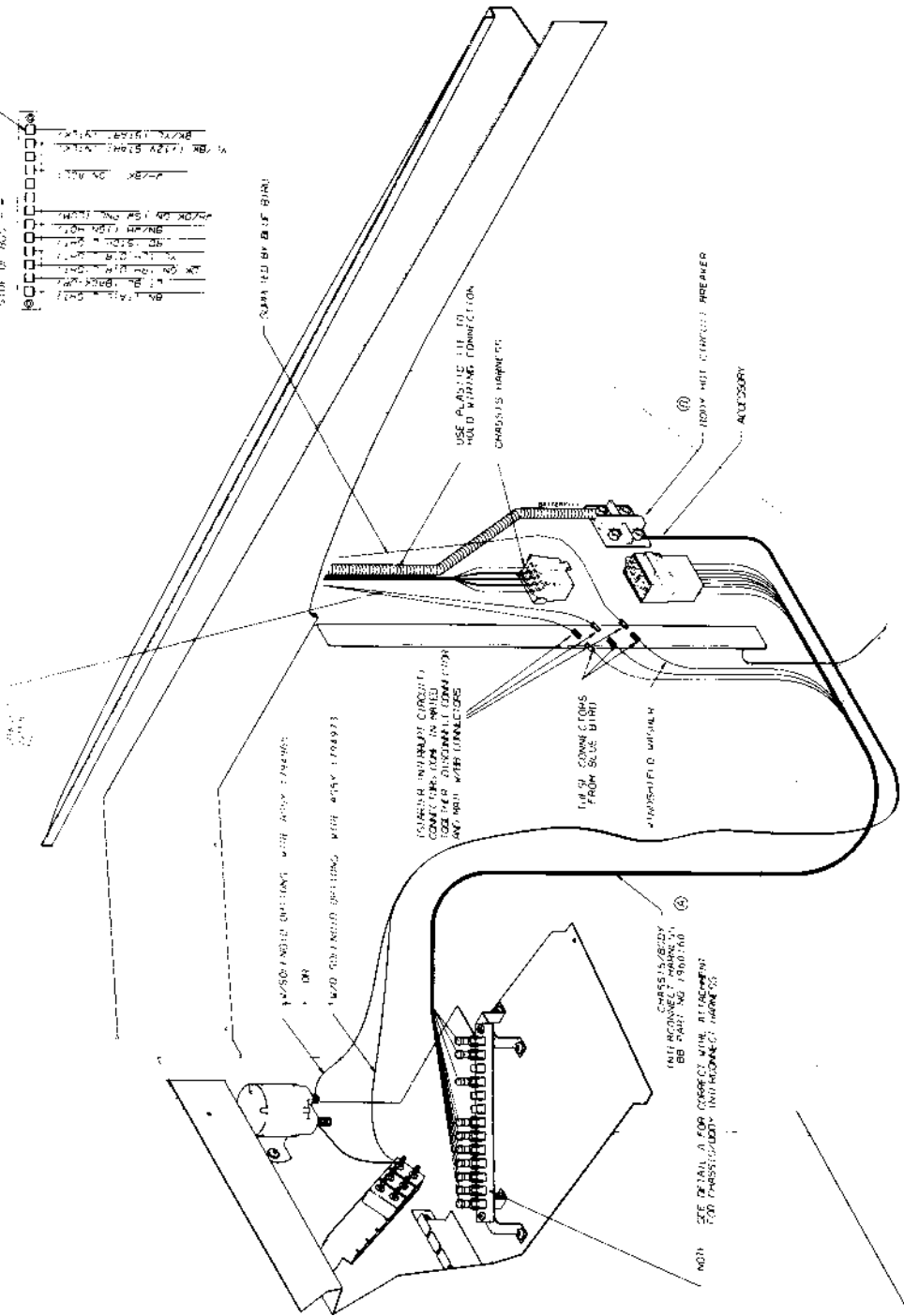



# VISIBILITY EQUIPMENT REQUIRED BY FMVSS

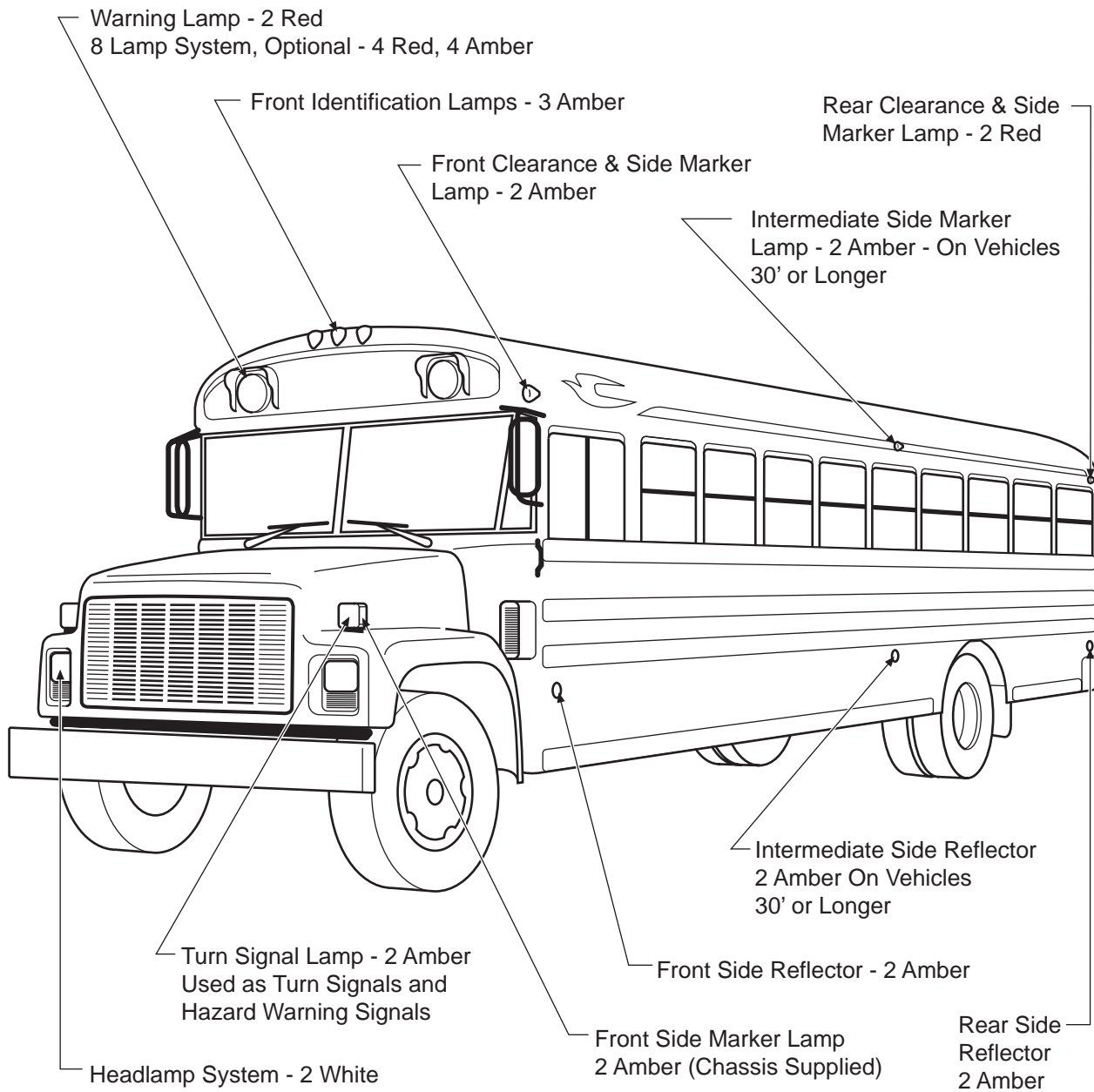

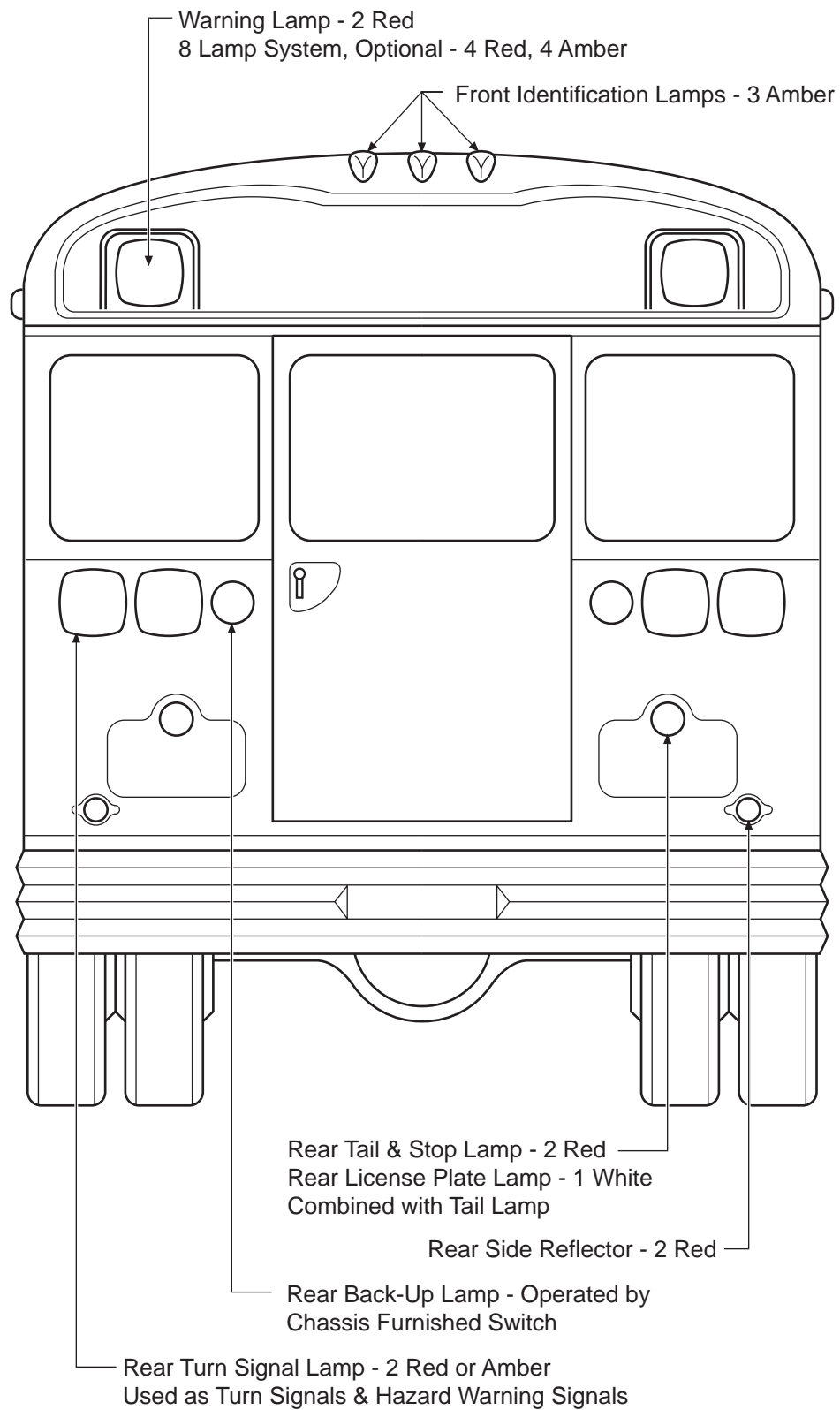

# MIRRORS & MIRROR ADJUSTMENT

**WARNING:** The vehicle's mirror system has been designed to comply with all field of view requirements, but it is the owner's responsibility to adjust the mirrors properly before placing the vehicle in service and to maintain the adjustment during the service life of the vehicle. Mirrors provide additional driver visibility on buses. To be effectively used mirrors must be properly adjusted for each driver and the driver must be aware of the limitations on viewing area that exists even when mirrors are properly used. Mirrors are not a substitute for proper driver training and the exercise of driver care in operating the vehicle and loading and unloading of passengers. Do not move the bus until you have accounted for each passenger that has disembarked and have confirmed that the passenger is clear of the bus. Failure to follow these procedures could cause serious injury or death.

Left and right front fender mounted convex crossview and left and right front fender mounted rearview mirrors are required equipment on all Conventional, Type (C), buses.

## INTERIOR MIRRORS

Inside rearview mirrors are adjustable by loosening the bolts and nuts in slotted holes. Adjust the mirror to afford the operator a good view of bus interior and roadway to the rear.

**WARNING:** Many school bus passengers are energetic children who are small and playful and do not understand the hazards of buses. After unloading, some children could be outside the field of vision of your mirrors or could quickly dart into such a place. Do not move your bus after unloading passengers until you have confirmed the location of every child who got off and have confirmed that each child is completely clear of the bus. Failure to follow this procedure could cause serious injury or death.

## 8" DIA. SUPPLEMENTAL EXTERIOR REARVIEW MIRROR

Some units may be equipped with two (2) 8" elliptical mirrors, one on the LH side and one on the RH side, which are designed to supplement the view provided by the outside rearview driving mirrors. The RH 8" elliptical mirror is attached to the RH outside rearview mirror mounting bracket as illustrated, and is viewed through the RH windshield. The LH 8" elliptical mirror is attached to the bus body and is located so as to be viewed through the LH windshield.

Proper adjustment is necessary for any mirror system to perform as designed. The following adjustment should be used to allow the driver to obtain the maximum viewing area with the mirror system.

Position the RH 8" elliptical mirror in the location illustrated. Adjust the 8" elliptical mirrors on both the RH and LH side to provide the seated driver a view of the ground directly below the outside rearview driving mirrors, and rearward to overlap the view provided by the outside rearview convex driving mirrors.

**CAUTION:** A convex mirror has a curved surface and is designed to provide a wide view with minimum distortion. However, persons or objects seen in a convex mirror will look smaller and appear farther away than when seen in a flat mirror or viewed di-

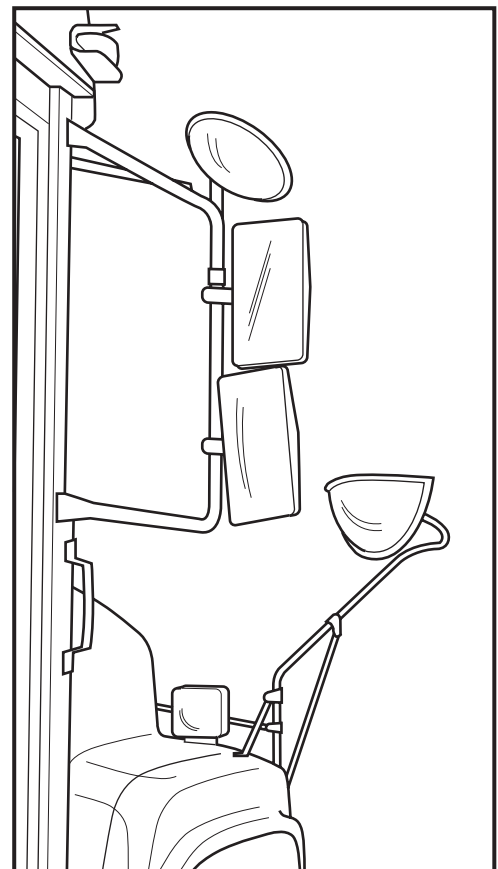
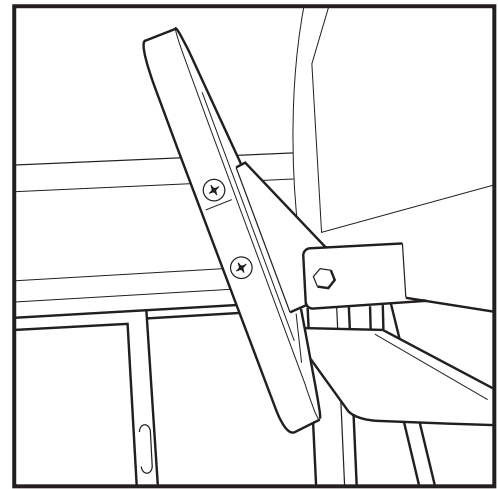

rectly. Therefore, use care when judging the size or distance of a person or object seen in a convex mirror. Wait until you can view the person or object in a flat mirror or direct view to determine their size and distance.

## EXTERIOR REARVIEW

Standard equipment on all school buses is comprised of 4 outside rearview driving mirrors. (2 per side), and 2 elliptical crossview mirrors, (1 per side). The outside rearview driving mirrors include (1) 6.5"x 10" flat mirror and (1) 6.5"x10" convex mirror each side. The outside rearview driving mirrors are designed to provide the seated driver a view of the roadway to the rear and to the sides of the bus. The elliptical crossview mirrors are designed to provide a seated driver a view of all areas around the front of the bus not directly visible to the driver. The elliptical crossview mirrors are designed to be used to view pedestrians while bus is stopped. **DO NOT USE THE ELLIPTICAL CROSSVIEW MIRRORS TO VIEW TRAFFIC WHILE BUS IS MOVING. AS IMAGES IN SUCH MIRRORS DO NOT ACCURATELY SHOW ANOTHER VEHICLE'S LOCATION.**

Proper adjustment is necessary for any mirror system to perform as designed. The following adjustment sequence should be used to allow the driver to obtain the maximum viewing area with the mirror system.

1. Adjust the driver's seat to the desired position.
2. Adjust the RH flat driving mirror so that the tops of the side windows are visible in the upper edge of the mirror, and so that the RH side of the bus body is visible in the inside edge of the RH flat mirror.
3. Adjust the RH convex driving mirror so that the view in the top of the convex mirror overlaps the view provided by the RH flat driving mirror, and so that the RH side of the bus body is visible in the inside edge of the RH convex mirror.
4. Adjust the LH flat driving mirror and the LH convex driving mirror following the same procedures described for the RH mirrors. Refer to steps #2 and #3 above.
5. Adjust the elliptical crossview mirrors by positioning each mirror head so that the center of the mirror is approximately flush with the side of the bus body.
6. A final adjustment should be made to the mirror system so that the seated driver can view the areas required by FMVSS 111, including the entire top surface of cylinders M and N when located as illustrated and rearward a

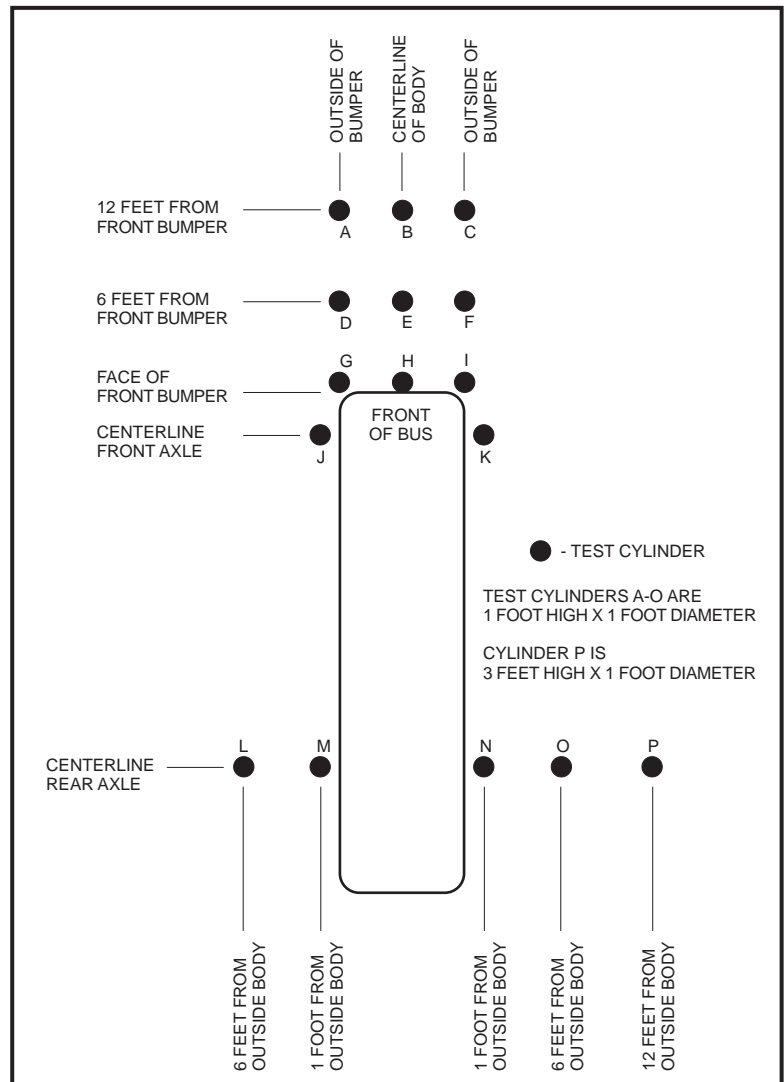

minimum of 200 feet (measured from the mirror surface) using the outside rearview driving mirrors. The elliptical crossview mirrors should be adjusted to provide the seated driver a view of the entire surface of any cylinder A thru P (when located as illustrated) not visible by direct view of the driver. The view provided by the elliptical crossview mirrors must overlap the view provided by the outside rearview driving mirror system.

**Maintenance:** All mirrors should be cleaned weekly or more often if conditions warrant. Cleaning should be done with an ammonia solution to insure that mirrors are not obstructed. Be sure that mounting fasteners are kept tight so that mirrors will not vibrate. Check weekly and retighten, if necessary.

## EMERGENCY EQUIPMENT

The fire extinguisher is located in the right front corner of the bus body near the floor. Your unit may be equipped with a 2 3/4, 4 1/2, 5 or 6 pound extinguisher. Check quarterly to make sure it is fully charged.

If your unit is supplied with triangular reflectors and fuses, they are located near the fire extinguisher.

The first aid kit is mounted above the windshield on the right hand side of the bus body. Different size kits are supplied in various bodies because of different state specifications. Check quarterly to see if fully equipped.

In units with an optional locking emergency equipment compartment in the front upper panel above the windshield, all emergency supplies are located behind a door which is labeled with a list of compartment contents. To meet state regulations, the door locking mechanism is connected to a buzzer system that sounds if the compartment door is locked when the ignition is turned on.

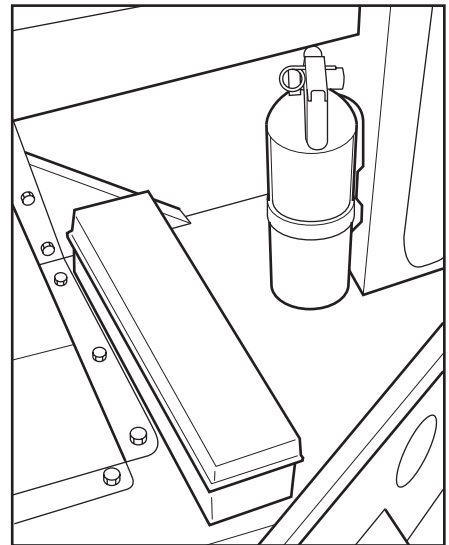
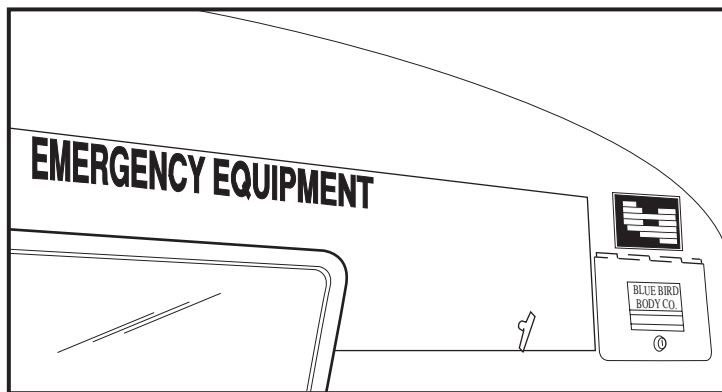

## RECOMMENDED WARNING DEVICE POSITIONING

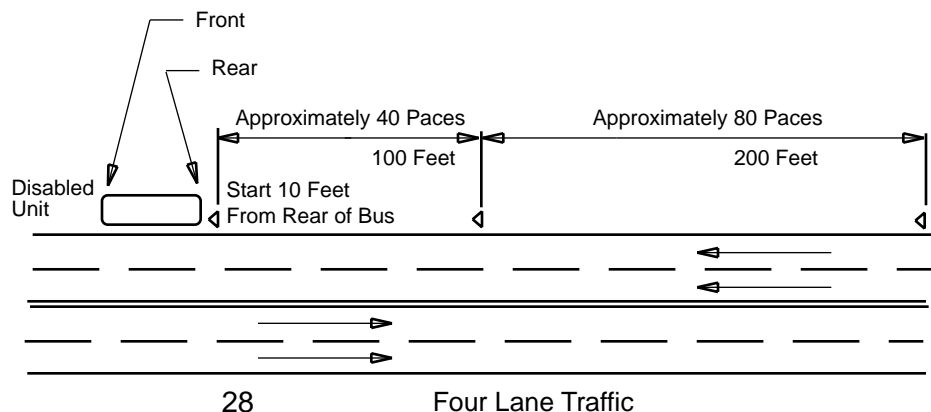
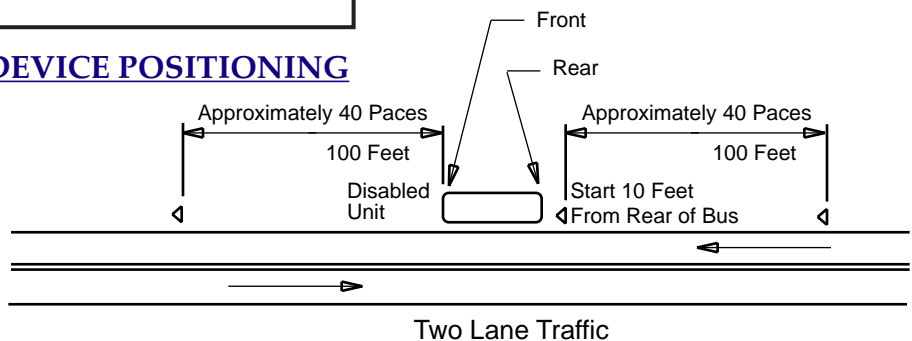

# EMERGENCY EXITS

Emergency exits are clearly identified by the words “Emergency Exit.” Operating instructions are written close to each exit. Some units are equipped with an audible alarm device signifying an emergency exit is unlatched or open. If, when turning the ignition switch on, a buzzer sounds, check emergency exits to see that they are completely closed. All emergency exits meet Federal Motor Vehicle Safety Standard 217 “Bus Window Retention and Release.” These illustrations show various types of emergency exits.

All emergency exits should be inspected and operated daily to insure they are labeled and operate properly per the instructions provided.

Also see Transpec Safety Vent.

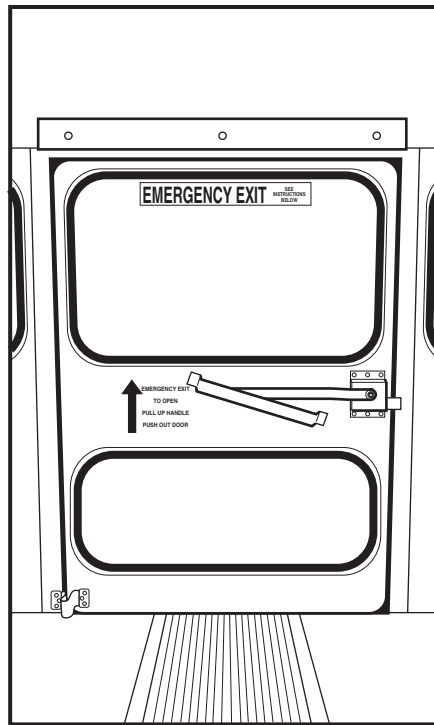

Rear Emergency Door

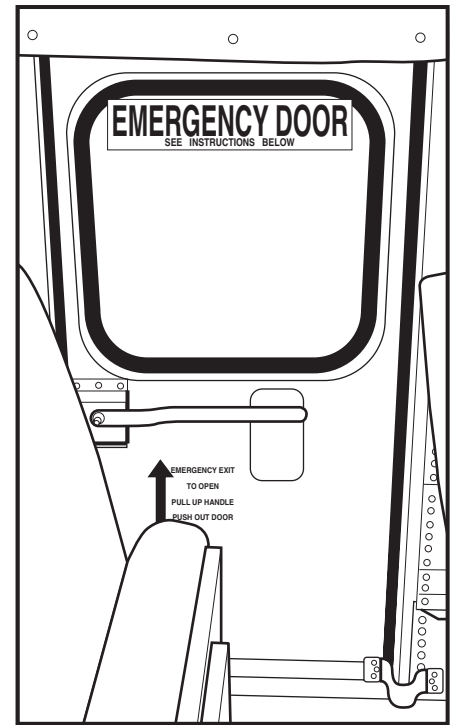

Side Emergency Door



Split Sash Pushout Window

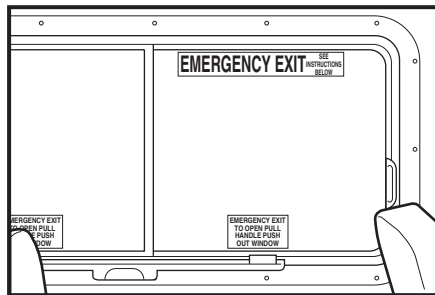

Transit Sliding Pushout Window

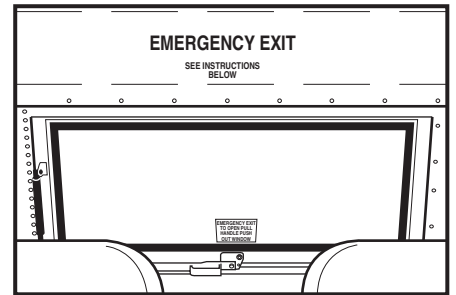

Rear Emergency Window

# WHEELCHAIR LIFTS

For the Conventional, Blue Bird supplies lifts from Braun and Collins. Each vendor provides its own publication for information on maintenance, lubrication, troubleshooting and other important items that are imperative to the smooth operation and safety of wheelchair lifts. These publications are supplied with vendor maintenance documents per order.

Illustrated is the wiring diagram of the buzzer circuits for the wheelchair lift door. The buzzer indicates whether the door is unlatched, opened part of the way, or opened completely (at which time buzzer does not sound).

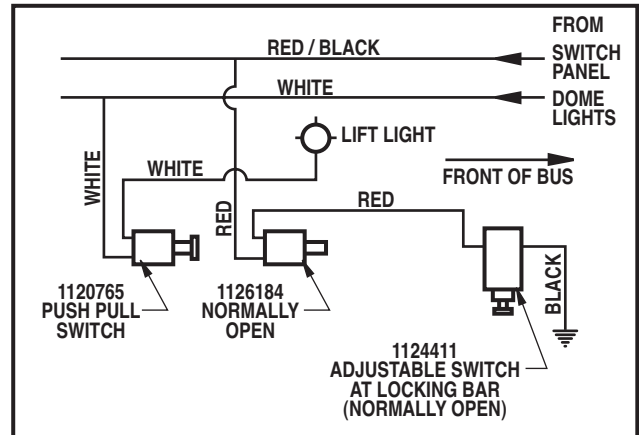

# TRANSPEC SAFETY VENT

## MAINTENANCE CAUTIONS

Transpec Safety Vents are designed to provide years of reliable service with a minimum of maintenance. All components are rust proof with life time finishes, and moving parts are Teflon coated to eliminate need for lubrication. Use of lubricants, paints, or other coatings-such as graffiti deterring spray-is not recommended.

Suggested maintenance includes periodic inspection of attaching fasteners for evidence of loosening due to tampering, and regular cleaning with mild soap and water. Although there are other cleaning solutions available, some of them contain solvents and other chemicals that can attack the high strength materials used in the production of safety vents.

It is the customer's responsibility to ensure that cleaning solutions are compatible with the materials used on safety vents.

Graffiti removing cleaners often contain acetone, ether, lacquer thinner, or other solvents known to destroy the high strength properties of many engineering plastics and use of these cleaners must be avoided.

Graffiti resisting coatings often leave a sticky residue that interferes with smooth up / down movement of the ventilator mechanism. Some of these coatings also contain solvents that will reduce the strength of certain components. Use of these coatings on safety vents is at considerable risk and should be avoided.

## SERVICE AND REPAIRS

All components used in the production of Safety Vents are available as service parts, except for one hinge that represents a possible hazard when improperly reattached to a hidden tapping plate that is often damaged, whenever the hinge is damaged. The tapping plate is permanently laminated between the inner and outer cover assemblies and can neither be inspected nor replaced. It is, therefore, necessary to replace the entire assembly following damage to the hinge.

**CAUTION: Hinge assembly is critical and hinge should never be removed from cover assembly. Fasteners used in this assembly are special and have critical torque requirements and tamper resistant heads to discourage tampering.**

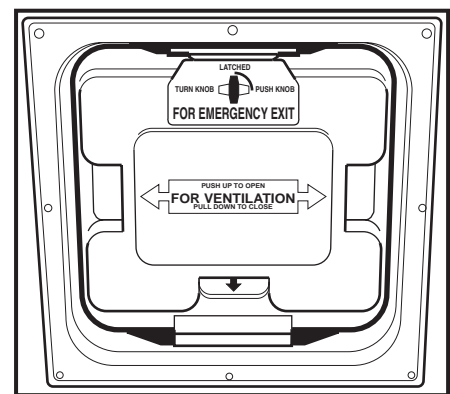

Roof Hatch



# STOP ARMS

Stop arms are required on Conventional school buses per FMVSS 131. Stop arm assemblies are purchased as a kit; many different kits are available with blades to meet all state requirements. The stop arm is located on the left-hand side of the body under the driver's window. Stop arms are most commonly operated by a manual switch located in the switch panel.

For air stop arms the manual switch activates an electric solenoid valve controlling the flow of air. Optionally, the solenoid valve may be activated by the warning lamp system. This system works in conjunction with the air system on the chassis. No preventive maintenance procedures are required with these systems.

With the electric stop arms the manual switch activates the control relay of the stop arm. Optionally, the stop arm may be activated by the warning lamp system. The following preventive maintenance procedures should be followed for the electric stop arm.

## Monthly

- Oil the dual-action breakaway hinge at four (4) pivot points with a high performance, penetrating lubricant. Tri-Flow™ (DuPont) with teflon is recommended.
- Check and make sure breakaway portion of hinge is free and movable.
- Check fasteners for tightness.

## Quarterly

- Remove front and rear covers of base and check internal fasteners for tightness.

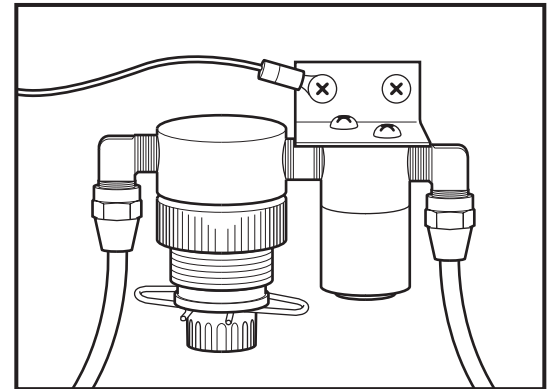

AIR REGULATOR

On units equipped with air stop arms, the air pressure may occasionally require adjustment to insure proper opening and closing of the stop arm. Air regulator is accessible by opening the access panel adjacent to the switch panel. Regulator is identified as shown. To regulate the air pressure, remove the wire retaining clip below the regulator knob and pull the red lock ring out. Turn the knob counterclockwise to decrease the pressure, then slowly increase the pressure (turn knob clockwise) until the stop arm hinge is extended to approximately 90 Degrees. Relock knob by pushing in the red lock ring and reinstalling wire retaining clip.

The "STOP" sign must extend and if equipped with lights, the lights must be operating at anytime the red lights of the warning light system are flashing. There are some unique, state-designed warning light/stop arm systems that permit the stop arm to be withdrawn while warning lights are in operation. For those situations an audible alarm sounds to alert the driver of the condition.

## AIR STOP SIGNS AND CROSSING ARM TROUBLESHOOTING

### AIR STOP SIGNS AND CROSSING ARMS

#### Problem:

Signs won't open to 90 Degrees.

#### Areas to Check:

1. Faulty diaphragm - same as above.
2. Faulty solenoid valve - same as above
3. Air pressure regulator - air pressure regulator must precede the solenoid to prevent damage to the solenoid or to the diaphragm. Excessive pressure may cause damage to both the solenoid and the diaphragm. Pressure should not exceed 12 lbs.



4. System leak - check to make sure that the air pressure supplied to the solenoid valve or the diaphragm is equal to 10 to 12 lbs. Again - **CAUTION - not to exceed 12 lbs. of pressure is very important. Excessive pressure will cause damage to the diaphragm and the solenoid valve.**
5. Loose fasteners - same as above.

**NOTE:** Solenoid valves must be checked under pressure while activation of the electric solenoid is taking place.

### **ELECTRIC STOP SIGNS AND CROSSING ARMS:**

In order to troubleshoot an electric stop sign or crossing arm it is important to first understand how to install the stop signs and crossing arms. The electric installation can be accomplished in two different manners.

#### **Example #1:**

- A. Dark blue to a switched 12V terminal. Red to a constant 12V terminal. Green to a proper ground. This example would use the blue wire to activate the stop sign and to deactivate the stop sign.

#### **Example #2:**

- B. Dark blue and red to a constant 12V terminal. Green to a grounded switched terminal. Example #2 would use the green wire or the ground to activate and deactivate the stop signs or crossing arms.

One of the major features of the electric stop signs and crossing arms is that all of the works are in the base. You can troubleshoot the electric stop sign by first:

- (A) Determining if the proper wiring installation has been achieved and that 12V and ground are available where required.
- (B) Remove the rear cover of the base.
- (C) Remove the red wire from the relay (wires lead to terminal on motor).
- (D) Remove red wire from the limit switch.
- (E) Replace the red wire on the limit switch with the red wire from the motor.
- (F) With a battery charger or any other 12V source ground the motor terminal (black wire) and attach the positive 12V to the red wire terminal on the motor. The motor should begin to activate and run continuously until you remove the red wire.
- (G) With a probe attached to the 12V positive side of the battery charger identify the black and light blue leads on the limit switch at the motor base and with a 12V positive probe select either the black or the light blue terminal and attach the probe to the lead of the limit switch. One of two conditions will occur - either the motor will begin running or it will not. If the motor runs it should proceed until the CAM circles and deactivates the limit switch causing the motor to stop. At that time switch terminals with the limit switch to either the black or light blue depending on where you started and again the motor should begin to run until the CAM positions itself to deactivate the limit switch. If both these points prove to operate the motor then the limit switch, CAM and motor assembly are functioning. If you have verified that you have the proper wiring installation as identified in the opening paragraph then your problem rests with the relay. Replace the relay. This should render the sign operational again.

### **STOP SIGN BLADE FAILURE**

#### **Problem:**

Lights do not function.

#### **Areas to Check:**

1. Check to insure that the light bulb is working.
2. Check to insure that the ground strap is secure.
3. Check to see if 12V is being supplied to the light bulb.

It is important to note that there have been improvements made to the socket and pigtail. The improvements are as follows:

- A. Screws versus rivets make replacement possible with a common nut driver.
- B. A two-wire socket and pigtail eliminated the braided wire ground strap which on occasion failed in the field. This will help insure that the ground is intact throughout the operation and life of the sign.
- C. Lower temperature protection (minus 40-wire and vinyl tubing) have been added to insure a broader temperature range in northern and southern climates.

**Problem:**

Fading to the blade surface.

**Areas to Check:**

- 1. Steel blades are painted with a red paint, which are prone to bleaching due to the pigments. If the blade becomes faded possible solutions are to repaint or replace the blade. Specialty recommends the replacement of the blade due to the labor savings and cost efficiency. Approximate cost of replacement blades on a steel blade is \$8-10 depending on the quality.
- 2. Aluminum reflective signs have improved in technology to the point where blades in southern exposures are now lasting five to seven years. This is due to ink improvements where the pigmentation in the inks actually darkens over the life of the sign. Replacement now is due to sub-straight failures on Engineering grade versus ink failures as in the past. Decals are available for Engineering grade and high intensity sign runs you approximately twice as much as a steel blade. All of our products; air, vacuum and electric are available with a high intensity face.

## BODY TIE-DOWN

Tighten the tie down clamp bolts and the body shear bolts at 1000-2000 miles and quarterly thereafter.

Shear bolts should be tightened to 22-28 ft. lbs. and body tie down bolts should be tightened to 37-41 ft. lbs. of torque. The two shear bolts are located under the body at the rear of the chassis near the rear bumper. Tie down clamp bolts are located at the front floor, on brackets around the radiator and at the chassis firewall.

The body is mounted with pads of high-durometer rubber between the floor and chassis frame rails. The rubber absorbs shock, deadens sound, and maintains tension on the tie down clamps. Be sure the pads are in place when tightening down the tie down clamps.

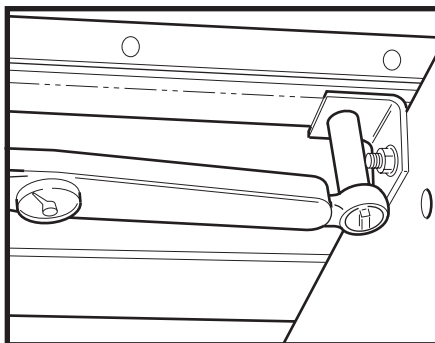

TIE DOWN ANGLES

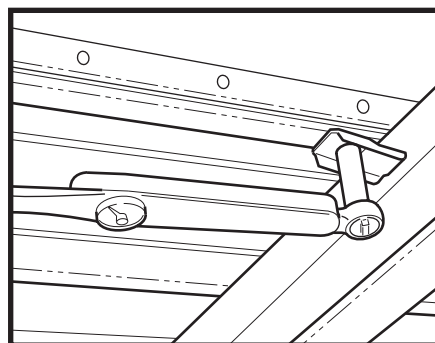

TIE DOWN CLAMP BOLTS

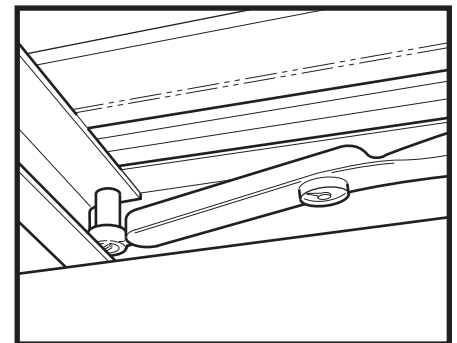

MOUNTING BOLTS AT REAR NEAR BUMPER

**WARNING: Failure to follow the procedures for tightening bolts, either by failure to tighten on schedule or by failure to conform to the torque poundages, could create a danger of separation of the body and chassis, thereby causing possible personal injury or death.**

# DOORS

---

## CONTINUING MAINTENANCE REQUIREMENTS

1. Keep working parts of control tightened.
2. Lubricate all working parts periodically, including hinges and overhead controls. (See Body Component Maintenance Chart)
3. Repair or replace worn seals.
4. Maintain proper door opening and closing adjustment. (See Body Component Maintenance Chart)

## OUTWARD OPENING

Doors are mounted in a prefabricated framework which eliminates effect of body construction variations on door and seal operation. Doors are suspended completely on scaled ball bearings located at the top corners of the framework, inside the body. The interlink connection between the doors is a single assembly with oppositely threaded spherical bearing rod-end connectors on each end providing simple link length adjustment without disassembly. Simply loosen the lock nut, turn the tube, and retighten the nut when satisfactorily adjusted. The geometry of the mechanical link between the doors causes the rear door to close well ahead of the front door, so that the front nosing seal rubber always overlaps the rear. Oil impregnated bronze bearings serve as pivots, not supports, in the lower corners of the framework. All controls and mechanisms and the complete lower step tread are sealed inside the bus and out of the weather when the door is closed.

In the interest of safety through maximized driver visibility, the doors have been designed to have as much clear glass opening as possible. A four inch wide pad is mounted to the header cover over the opening.

The manual control is the Blue Bird cover over center locking type with built-in saf-latch. The door ease-of-operation facilitates use of a short handle arm, so the handle is six inches closer to the driver in the open position than with the jack-knife door.

The electric operator is also the linear motion type with a ball-screw drive. It is connected to a lever off the front door. Mechanically operated switches control automatic stop positions as well as stepwell and warning lights.

## OUTWARD OPENING (AIR DOOR)

The air operator is a simple linear cylinder connected to a lever on each door and located inside the header cover. An interconnecting link between the doors controls their operation sequence. A safety release valve is located over the door and stepwell lights are operated by air pressure switches inside the header cover. Door operation by the driver is managed by a simple two-way manually operated valve, and air pressure holds the door either open or closed depending on the position of the valve. The operation speed is adjustable by use of flow control valves at cylinder inlet and outlet.

## JACKKNIFE DOOR - (If so equipped)

1. Loosen the roller bracket at the top of the rear door.
2. Adjust the length of rod (between the door control and the door) and the location of the rod end bracket on the door for proper open and closed position.
  - a. Lengthen the rod if the door opens too far and does not close against the top seal.
  - b. Shorten the rod if the door closes too hard and does not open far enough.
  - c. Move the rod end bracket forward if the door does not close against the seal and does not open far enough.
  - d. Move the rod end bracket rearward if the door opens and closes too far.
3. Attach the roller bracket to the rear door and adjust.
  - a. If the rear door hangs in the track when starting to close the door, move the bracket to the rear.
  - b. If the rear door does not open to the front enough, move the roller forward.

4. Perform the following adjustments and maintenance for ease of operation. The top of door should be approximately 3/8 inch below door header.
  - a. Move door upwards so that rubber door sweeps do not drag on stepwell treads. Adjust door height by loosening bolts and nuts that attach front door panel to front hinge. Holes in hinge are slotted. This permits vertical adjustment of door.
  - b. Assure that top edge of door nosing rubber does not drag on door stop header rubber. Remove the first three upper screws in the inner and outer nosing rubber retainer strips and force the nosing rubber downwards. Replace screws after the rubber nosing has been adjusted.
  - c. The rear upper corner of the rear door panel should not drag on rubber door stop on the header. To provide the required clearance, move the door roller bracket towards the rear of the bus. This effectively will move the door panel away from the door stop rubber.
  - d. Clean stepwell rubber treads and lower door rubber sweeps regularly. Cleaning these surfaces will reduce friction as the door is operated.
5. Assure that the door control rod end bracket is mounted squarely on door. If bracket is not square to the door, the yoke end pivot pin will bind. Adjust by loosening screws and tighten after bracket has been squared up.
6. Inspect the pivot nut on rod end bracket for burrs or other surface irregularities. Grind or file pivot nut so that its upper and lower surface is smooth.
7. Lubricate door hinge pin with a spray type lubricant (LPS No. 1). Lubricant should penetrate behind each hinge lug. Door hinge will operate quietly if properly lubricated.

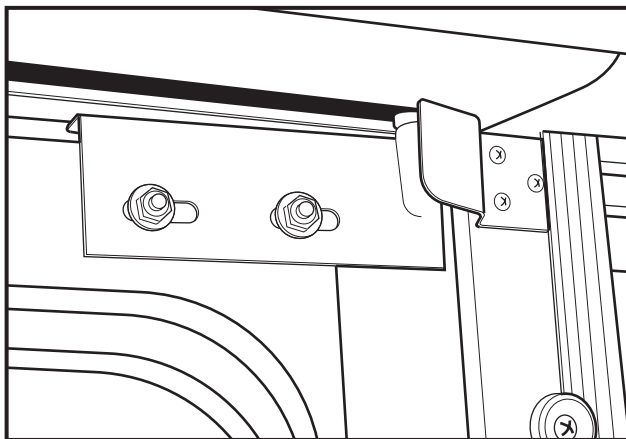

ROLLER BRACKET

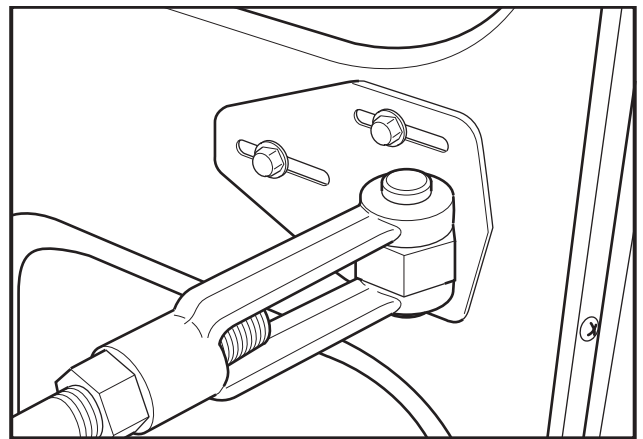

ROD END BRACKET

## **ELECTRIC OUTWARD OPENING DOOR**

The electrically operated outward opening door has a linear actuator that moves a lever attached to the front door. To open the door, hold the spring loaded switch in the driver's area in the "open" position until the door stops moving. An automatic switch stops the action of the door. To close the door move the switch to the "close" position and the door will stop automatically when fully closed. There is a keyed switch on the outside of the body on the cowl panel by the door that parallels the operation of the interior switch.

### **Emergency Release**

With the door in the fully closed position, pull the release lever in the header panel rearward as far as possible. You will feel the linkage release and then feel the lever snap into a "park" position so it will not return

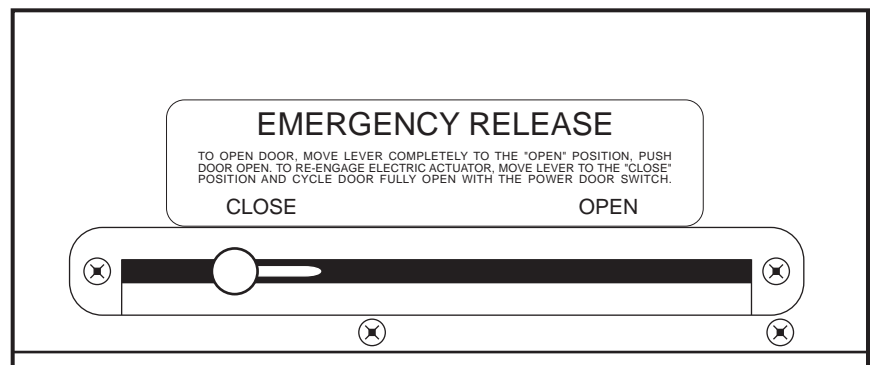

EMERGENCY RELEASE LOCATED IN HEADER ABOVE DOOR

forward when released. Push the door open to exit the bus. To reengage the release mechanism, move the lever in the header back to its forward position, and hold the driver operated spring loaded switch in the "open" position until engagement is obvious or until door is in fully open position.

### **SECURITY LOCK (Outward Opening Door)**

A key operated "bolt" slides into a hole in the header when the door is in the closed position and locked. This option also requires use of the hinged stop on the door control. If the lock becomes difficult to operate, remove access plate on the inner door panel and channel and lubricate with No. 2 lithium grease. (Access plate shown removed in illustration.)

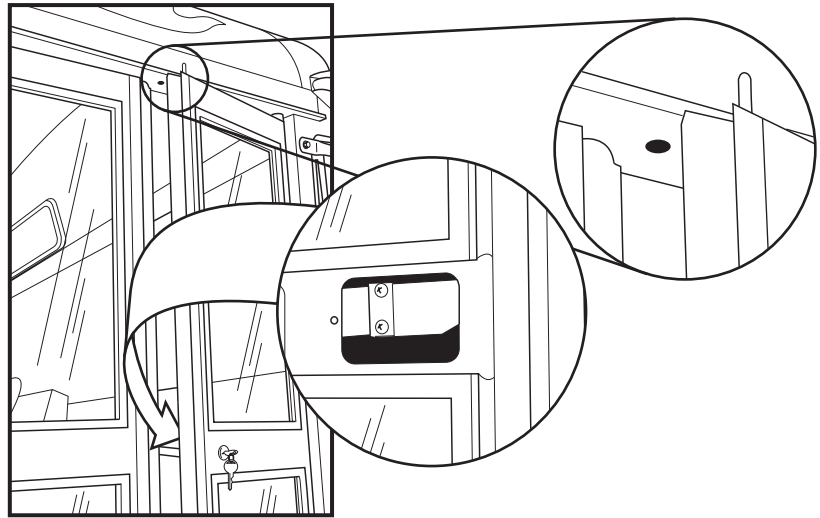

## **VANDAL LOCKS**

---

### **ENTRANCE DOOR**

The **Entrance Door Vandal Lock** release handle is located in the rear half of the entrance door. The handle rotates counter-clockwise to the latch position or 180° clockwise to the unlatched position. It can be key locked in either position. The latch engages a bracket on the front door.

Before using this vandal lock, the hinged stop on the door control cover must be flipped down to keep the door control from travelling over center when closing the door.

Lubricate vandal lock every 6 months or 6000 miles, whichever occurs first. Use LPS-1 or "Apply"™ type lubricant and spray into the bushing and shaft in the center at the base of the lock handle. Also spray lubricant into key lock mechanism. Rotate the lock handle to insure smooth operation.

### **EMERGENCY DOOR**

The emergency door vandal lock has a lock cylinder which is placed in the lock to make the emergency door inoperable. When the cylinder is in place in the lock, the coach cannot be started. To complete the ignition circuit, the lock cylinder must be removed from the lock and placed in the receptacle at the side of the door. When this is done, the circuit is completed and the coach can then be started.

No lubrication is required with this system.

### **SLIDING BOLT VANDAL LOCK**

The sliding bolt vandal lock, for the rear center emergency door, is an interior latch that prevents the door from being opened from the outside when engaged. The bolt is connected to an interlock assembly which prevents engine starting when the door is locked. If the lock is activated after the engine is running, an audible alarm is sounded in the driver's area.

Lubricate sliding bolt mechanism every 6 months or 6000 miles, whichever occurs first with LPS-1 spray lubricant.

# KEEPING YOUR VEHICLE LOOKING NEW

---

## WASHING YOUR VEHICLE

The best way to preserve your vehicle's finish is to keep it clean by frequent washings. Wash the vehicle in lukewarm or cold water. Do not use hot water or wash in the direct sunlight. Do not use strong soap or chemical detergents. All cleaning agents should be promptly flushed from the surface and not allowed to dry on the finish.

**CAUTION: Pressure washing may cause damage to finish. Pre-test pressure washer on similar surface prior to applying pressure and chemicals to your vehicle. Pressure washers using recirculated water should filter the water to remove abrasive grit.**

## POLISHING AND WAXING YOUR VEHICLE

Polishing with nonabrasive wax is recommended to remove accumulated residue and eliminate any "weathered" appearance.

## FOREIGN MATERIAL DEPOSITS

Calcium chloride and other salts, ice-melting agents, road oil and tar, tree sap, bird droppings, chemicals from industrial chimneys and other foreign matter may damage vehicle finishes if allowed to remain on painted surfaces. Prompt washing may not completely remove all of these deposits. Additional cleaners may be needed. When using chemical cleaners developed for this purpose, be certain they are safe for use on painted surfaces.

## FINISH DAMAGE

Any stone chips, fractures or deep scratches in the finish should be repaired promptly. Exposed metal will corrode quickly and may develop into a major repair expense.

## FLOORS AND FLOORCOVERING

It is imperative that the interior of the bus be kept clean and floorcovering is an important part of this maintenance. Regular cleaning and care will prolong the life of floorcovering and improve the general appearance.

Floorcoverings should be swept daily and mopped weekly with a mild detergent and water. Do not use floor sweeping compounds. Be sure that dirt, pencils, paper etc. that may cause the emergency door to improperly seal are removed. Do not use harsh detergents and excessive amounts of water. Do not use a water hose to wash out the bus, deterioration and damage to the wood floor could occur.

**WARNING: Petroleum products, such as oil and grease, quickly deteriorate the floorcovering. These type products should be removed, as soon as possible.**

Continuous care must be exercised in the step well area where foreign objects can create a safety hazard. Soil and debris cannot be permitted to build up as this not only creates a hazard for passengers but hinders door operation and door sweeps. Insure that screws for floor trims and aisle trims are seated tightly, so as not to loosen and create a safety hazard.



# HEATERS

---

## GENERAL INFORMATION

Blue Bird heaters are hot water type which depend on heat generated by the engine for their function. Heat from the engine is picked up by the engine coolant which is pumped through the heaters inside the body and back into the engine. A typical heater inside the body is made of a heat exchanger coil and fans which move air across the coil. Air moving across the coil picks up heat from the engine coolant and transfers it into the body.

Satisfactory performance of the body heaters is basically dependent upon:

1. Adequate engine (coolant) temperature - this can be altered by thermostat rating (which should never be higher than recommended by the engine manufacturer) and/or shutters.
2. Adequate coolant flow - this varies with engine speed and can be increased if necessary by the use of an auxiliary water pump. The heaters are rated at six gallons per minute.
3. Proper fan operation - all motors have multiple speeds, and can most easily be checked for function by operating the motor switches individually and listening for the speed variations.

Many other factors affect performance, but the three mentioned are most basic.

## HEATER OPERATION

Be sure the engine radiator is full and all coolant flow valves are open. **For your own safety, do not leave the engine running while opening or closing valves.** Warm up the engine to operating temperature with the engine at fast idle, if possible, and turn on the heater fans and the auxiliary water pump if unit is equipped with one. Under extremely cold weather conditions, turning on the heater fans will cause the engine temperature to drop noticeably as heat from the engine is being transferred into the body, but as air temperature inside the body rises, engine temperature also rises. More heat will also be generated by the engine when it is caused to work in moving the vehicle. Once the engine is warm, heater fan motor speeds and subsequent air volumes across heater coils can be controlled at the discretion of the driver for best defrosting and ultimate passenger comfort. **NOTE:** See Heater Bleeding Instructions for completely filling cooling system.

The main front heater has a single motor, dual fan, high volume blower assembly. Internal baffling and controls allow the operator to direct essentially all the air from the blower to the viewing glasses, driver, or passengers as required. The controls on the switch panel marked "rear" and "defrost" at the extreme positions, direct total output to the defrost outlets, or the underseat duct, or proportionally between the two as positioned. The handle on the side of the heater housing under the driver's seat controls a sliding door that allows air to pass from within the heater into the driver's area, regardless of the switch panel control position. As the driver's outlet is opened, there will be a reduction in the air volume that can be directed toward defrosting or other passengers. The best balance if needed can be determined and controlled by the operator.

FOR MAXIMUM DEFROST AIR OUTPUT, the fan switch should be in the #3 position or high-speed position, the rotary control knob should be turned to "DEFROST" and the driver's outlet should be "CLOSED".

As the windshield is cleared, the driver's outlet can be opened as necessary and then some air directed toward passengers. The driver's comfort level should be controlled by position of the driver's outlet rather than fan speed, until the comfort level is adequate within the bus.

## DEFROSTING

Windshield fogging and frosting is caused by warm, humid air coming in contact with a cold windshield which causes the moisture in the air to condense and possibly freeze if the windshield is cold enough. The warmer the windshield, the less moisture will condense on it. During initial warm up, the controls should be set at maximum defrost air output to heat the inside of the windshield glass as much as possible. If the defrosters are not turned on until the condensation starts, it is more difficult to heat the glass and overcome condensation.

During warm-up, without passengers, the heater intake air should be set on the "recirculate" or "inside air" position. As passengers are loaded onto the bus, the moisture content of the air inside the bus increases. The heater air intake should always be set on the "fresh air" or "outside air" position when passengers are on board. The most difficult conditions will be encountered when there is a large passenger load which must remain on the bus for extended periods of time, such as on a charter or over the road activity trip. Travelling at highway road speeds causes accelerated heat dissipation through the windshield glass, and each passenger continually adds to the moisture content of the air within the bus. After a period of time the moisture concentration can become quite high. This condition can be improved by slightly opening the forward driver's window, allowing the moist air to escape into the low pressure area outside the bus at that location and by operating the heater blower at high speed with output air directed toward the windshield. If bus is equipped with adjustable static air vents in the roof, they should be kept open, and exhaust fans, if so equipped, should be used.

Auxiliary fans mounted on the dash or overhead may be helpful in windshield defrosting when used to force warm air from inside the body against the glass to warm it and evaporate moisture. They should not be directed to oppose the flow of air from the defroster outlets but to assist that flow if possible. Many different variations of auxiliary fan directions have been found to be effective under different conditions and their use on your unit can probably best be determined by trial.

Air distribution for defrosting in the entrance door area can be adjusted by rotating the diffusers.

## **ANTIFREEZE**

Your bus is equipped with a 50-50 solution of antifreeze and water. This solution protects to -20 degrees Fahrenheit. Driver should check antifreeze before taking unit into cold climate. For protection to -50 degrees Fahrenheit and below, the mixture should be 70 percent antifreeze to 30 percent water. Never have more than 70 percent antifreeze.

## **CARE AND CLEANING OF DEFROSTER FANS**

Defroster fan motor bearings are lifetime lubricated and do not require maintenance. Occasional cleaning of the blade and guard with a soft bristle brush and a vacuum cleaner or compressed air will help to maintain efficiency. As with any other fan, if the blade is damaged or imbalanced, vibrational damage can occur to the motor or surrounding components, so the blade should be replaced immediately.

**WARNING: Do not operate a defroster fan without the fan guard properly installed.**

### **Procedure:**

1. Remove front half of fan guard by gently separating plastic tabs with a screwdriver or other hard instrument. Be careful not to damage tabs, as these connect the front half of the fan guard to the rear half. Removing the guard will provide access to the fan should it need to be replaced.
2. To remove the fan blade, use a 3/32" Allen wrench in the set screw located directly behind the fan. This should loosen the fan blade for removal.
3. The rear half of the fan guard can also be removed if necessary. After removing the fan, remove the two nuts and washers on either side of the center point and lift guard off.

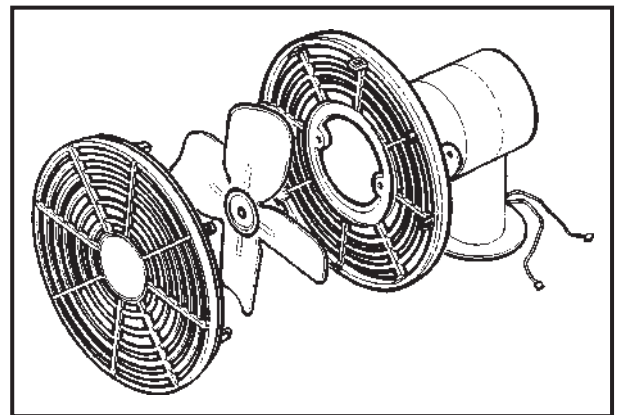



## HEATER DEFROSTER LOCATION

The blower in the front main heater contributes to keeping the driver's area glass clear of fog and frost. See OUTLET LOCATION diagram. Defrosting performance is enhanced greatly by the use of fresh air into the heater. Open front access panel and observe fresh air intake on driver's side of bus to verify the proper functioning of the fresh air intake.

Satisfactory performance of the body heaters is basically dependent upon:

1. Adequate engine (coolant) temperature - this can be altered by thermostat rating, which should never be higher than recommended by the engine manufacturer and/or shutters.
2. Adequate coolant flow - this varies with engine speed and can be increased if necessary by the use of an auxiliary water pump. The heaters are rated at six gallons per minute.
3. Proper fan operation - the three speed motor can most easily be checked for function by operating the motor switch and listening for the speed variations.

Many other factors affect performance, but the three mentioned are most basic.

## DRIVER/PASSENGER COMFORT

When defrosting requirements have been satisfied, the other openings can be set as necessary for comfort. The adjustable outlets on the rear surface of the dash can be directed toward the driver and/or passengers as desired. The auxiliary unit under the driver's seat has a two-speed electrical switch and it directs air upward for the driver's left side and forward around the steering column area.

## HEATER BLEEDING INSTRUCTIONS

Use of antifreeze (ethylene glycol type only) is recommended for summer or winter operation because of its corrosion inhibition and lubrication properties. A 50-50 solution of antifreeze and water (50% antifreeze) is preferred and it gives freeze protection to about 30 degrees Fahrenheit below zero. Ultimate protection is obtained at 68% antifreeze (about 92 degrees Fahrenheit below zero), a higher concentration of antifreeze should never be used.

If it becomes necessary to completely refill the chassis coolant system, the following procedure must be followed to insure adequate heater bleeding. During the bleeding process, it will be necessary to remove the radiator cap and refill cooling system several times to insure adequate coolant is available to replace purged air and coolant lost when bleeding.

**WARNING: Extreme care must be used when removing radiator cap. As coolant becomes hot, pressure is built up in the cooling system. Rapid venting and/or removal of radiator cap will cause coolant to boil up and spray out and can result in serious burns. Slowly vent off pressure before removing radiator cap.**

## PROCEDURE

1. With the engine off, shut all engine heater return gate valves or clamp closed heater return hose as close to engine as possible. Close heater hose supply line gate valve located on left hand front heater.
2. Fill cooling system completely, including surge tank with coolant and run engine for a few minutes to bleed air from cylinder block and heads.
3. Open the heater hose supply line gate valve located on left hand front heater. Turn on heater water pump, if equipped.
4. Using a suitable container to catch the coolant, run the engine between 2,000 and 3,000 RPM, loosen bleeder valve located in heater hose return line in engine compartment. Bleed air and coolant through bleeder valve until air is eliminated from heater system. (Stop bleeding when continuous stream of coolant comes from bleeder valve.)

**Note:** It will be necessary every few moments to refill the radiator or surge tank.

5. When all of the air has been purged from the heater system, open gate valve in heater hose return line or unclamp return hose.
6. Run engine between 2,000 and 3,000 RPM until thermostats open. To assist in deaerating the entire cooling system, accelerate the engine a few times before and after the thermostats open.  
**Note:** Thermostats have opened when upper radiator tank and radiator hose becomes hot.
7. Refill cooling system including radiator and coolant surge tank.

**WARNING:** Never idle engine in closed areas. Never sit in a parked vehicle for an extended period of time with the engine running. Exhaust gases, particularly carbon monoxide may build up. These gases are harmful and potentially lethal. Carbon monoxide is colorless and odorless, but can be present with all other exhaust fumes. Therefore, if you ever smell exhaust fumes of any kind inside your vehicle, have it inspected immediately by your dealer and have the condition corrected. Do not drive with exhaust fumes present.

**WARNING:** Extreme care must be used when removing radiator cap. As coolant becomes hot, pressure is built up in the cooling system. Rapid venting and/or removal of radiator cap will cause coolant to boil up and spray out and can result in serious burns. Slowly vent off pressure before removing radiator cap.

### **REMOVAL OF UNDERSEAT FAN AND MOTOR ASSEMBLY**

1. Remove screws securing outlet to heater, front and rear.
2. Lower outlet panel and move it toward aisle to clear end of heater.
3. Rotate outlet panel toward rear, away from heater, exposing fan and motor assemblies. Remove screws securing fan and motor to heater for service.

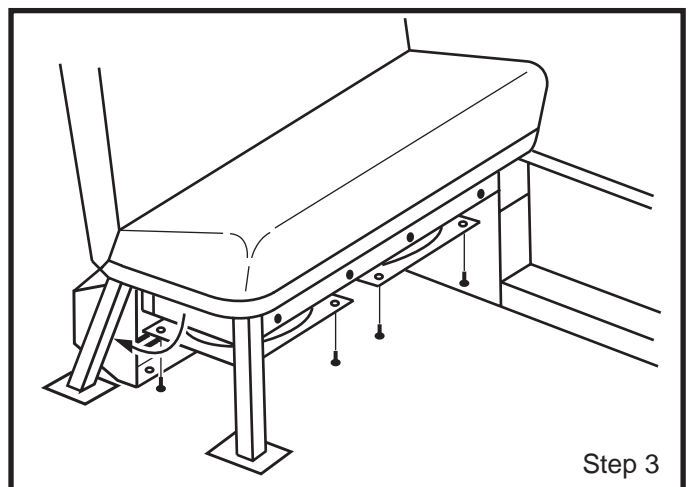
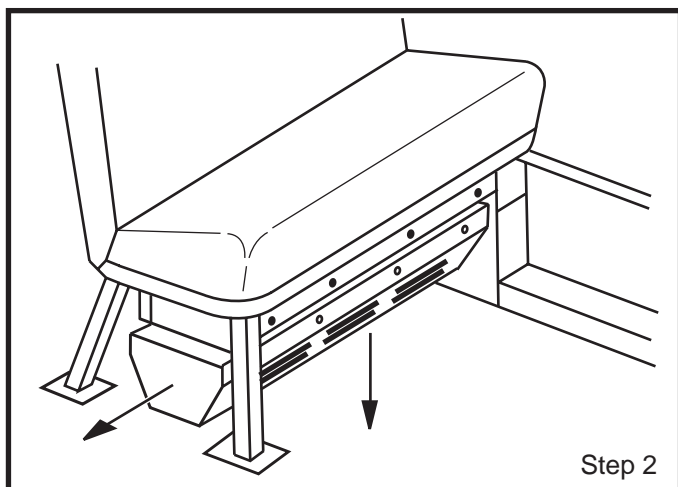
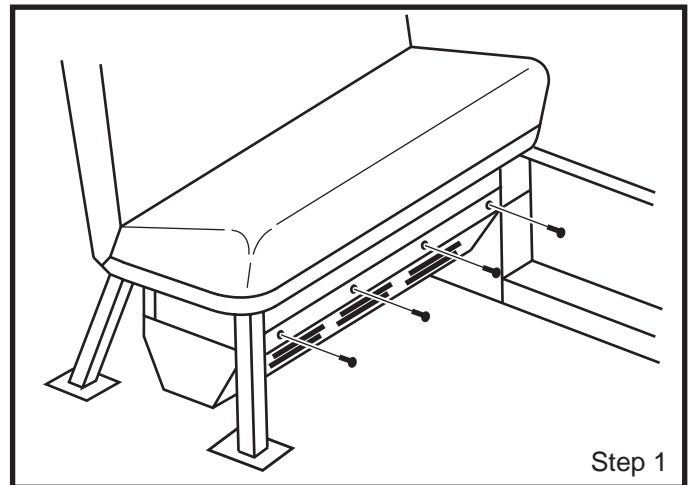

## **REMOVAL OF UNDERSEAT HEATER COIL**

1. Remove fasteners that secure seat cushion and remove seat cushion.
2. Remove screws securing heater to seat frame.
3. Slide heater toward aisle and remove heater to wall trims.
4. Remove hose cover trims at floor, exposing hoses.
5. Be sure to clamp the hoses shut in order to reduce spillage.
6. Loosen hose clamps and remove hoses from coil.
7. Move heater out from under the seat. Remove end caps and four (4) screws retaining the coil.

## **PREVENTIVE MAINTENANCE - to be performed annually**

### **Hoses**

Check all water hoses for kinks that can prevent water flow or chafing that can cause failure. Look and feel for hardening of rubber or cracks that result from aging. Hoses should be replaced when external cover tube cracks first appear. Hoses exposed under floor and in the engine area will deteriorate faster than those inside the body due to their exposure to the elements. Therefore, these hoses need to be checked more frequently.

### **Coils**

The heater will be most efficient when the coil and fins and air flow passages are kept clean and free from dust and dirt. The coil should be cleaned carefully with compressed dry air or vacuum, and a soft bristle brush. Damaged fins should be straightened with a fin comb to prevent air flow restrictions. The heater coil can be accessed through the right front inside access panel, or, for underseat heaters, removal of passenger seat cushions.

### **Motors, Switches, Blowers and Fans**

Motors are essentially maintenance free and do not require lubrication or cleaning, but excessive vibration caused by damaged blower wheels or fans can cause motor damage. Check wheels and fans for obstructions or damage by running each fan alone, then listening and feeling for irregularity. Replace damaged wheels or fans to prevent vibratory damage to surrounding and supportive housing parts and fasteners as well as motors.

Switches are also maintenance free, but loose wiring connections to switches or motors can cause excessive resistance and overheating damage. Wires to switches can be checked or repaired by removal of the switch mounting panel next to the driver.

### **Panels and Housings**

Fasteners which connect and retain structural and access panels should be checked and tightened as necessary. A loose screw can allow panel vibration, resulting in excessive noise, additional fastener failure, or metal fatigue cracks.

## **HOSE REPAIR**

Hoses are installed with as few joints as possible so as to prevent the possibility of leaking joints. If a portion of hose becomes damaged, a new piece of hose can be spliced in by use of 4 inch brass tube (Blue Bird part #1701903), and hose clamps. If hose must be replaced due to aging, the entire length of hose should be replaced. Air duct hose can be repaired with a good brand of wide PVC tape or duct tape.

## HEATER WATER CAPACITY CHART

**Note:** Water capacity of heaters includes tubing within heater enclosure.

Description	Capacity (Quarts)
90 Front Heater	4.30
50 R.H. Front Heater	1.56
50 Underseat Heater	1.50
80 Underseat Heater	2.34
1 Foot of Connecting Line	.17

**Example:**

60 passenger with a 50 R.H. front heater and 80 underseat heater located in overhang.

90 Standard Front Heater	4.30
50 R.H. Front Heater	1.56
80 Underseat Heater	2.34
76 Ft. of Heater Pipe with 0.17 quarts per foot	<u>12.92</u>
<b>Total Capacity</b>	21.12 Qts. (5.28 Gals.)

**NOTE:** Total capacity of complete system in this example is 21.12 quarts plus capacity of engine and radiator  
Refer to chassis manufacturer operating manual for engine and radiator capacity.

## HEATER SERVICE

Use the following two diagrams as guides in helping to perform service on the heater components.

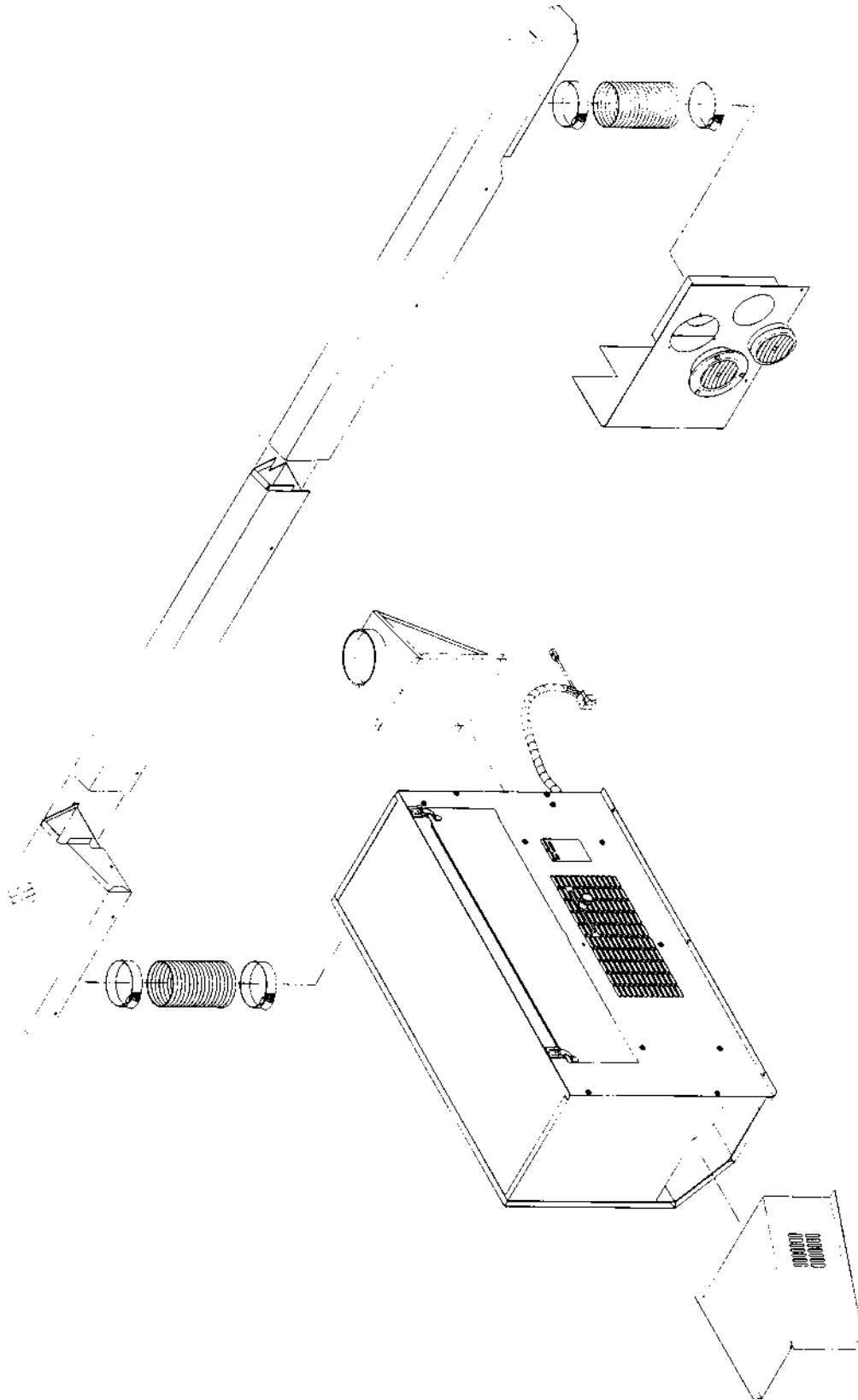

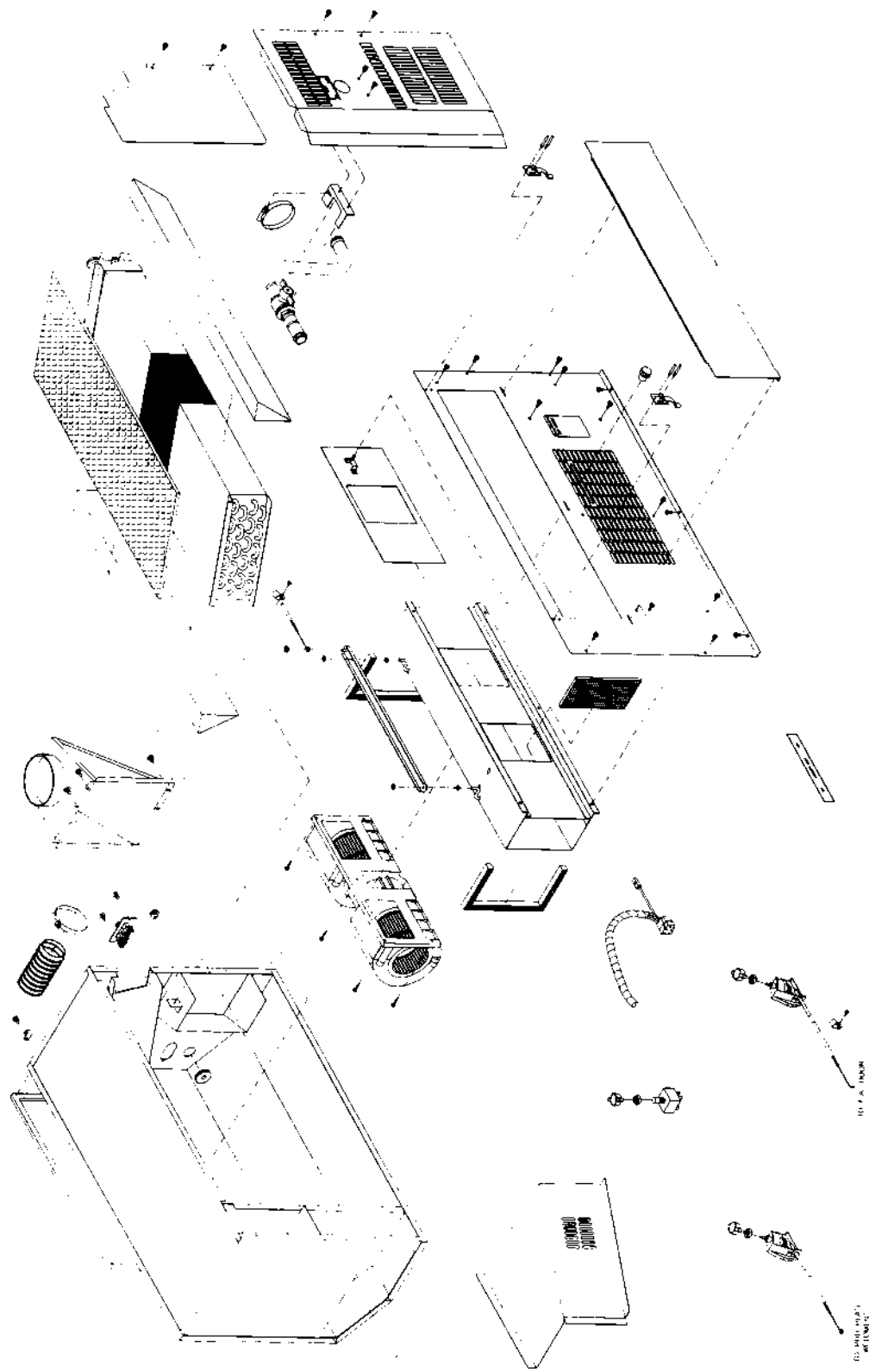

# WINDOWS AND WINDSHIELDS

## WINDSHIELD GLASS REPLACEMENT

The windshield is four-piece flat.

1. Remove vertical filler strip in glazing rubber on each side of broken glass; remove horizontal filler strip in glazing rubber on top and bottom of broken glass. It will be necessary to cut the horizontal filler strip after it is pulled past the glass.
2. Starting at a corner, push glass free of glazing rubber from inside of bus outward and remove.
3. Position new glass in glazing rubber.
4. Using installation tool, work glass into glazing rubber.
5. Seal glass to glazing rubber from outside of the bus with an adhesive sealant such as, Silastic 732 RTV Adhesive/Sealant.
6. Apply soapy solution to filler strip channel on glazing rubber to act as a lubricant for easier installation of filler strip.
7. Using filler strip tool, insert fillet strip into channel on glazing rubber.

## SPLIT SASH WINDOW & GLASS REPLACEMENT

**NOTE:** The glass used in our bus meets FMVSS 205 and 217. Therefore, when a glass is broken, it should be replaced with identical glass.

1. Remove four screws securing window frame to bow.
2. Pull window to inside of body and remove.
3. Remove 6 screws (3 on each side of window) holding assembly together.



Step 1



Step 2



Step 3



Step 4

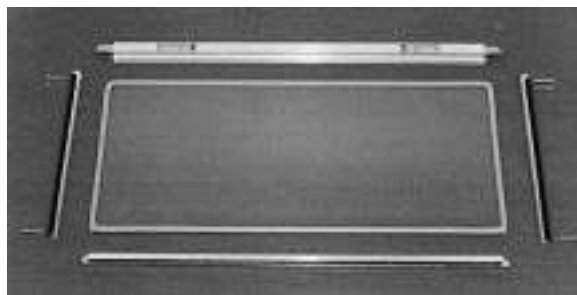

Step 5



4. On bottom glass, simply pull aluminum channel off top and bottom of glass.
5. To remove glass from top part of window, remove 6 screws holding frame around glass.
6. Reassemble window by reversing above procedure.
7. Apply weather seal caulking around window frame to prevent leaking.



Disassembled Window

**WARNING: When replacing broken or damaged glass, use extreme care at all times to prevent personal injury. This includes the use of proper replacement parts, tools and personal protective equipment, such as gloves and safety goggles.**

### WINDOW LATCH REPLACEMENT

1. Remove screw and block located in side channel directly above stationary glass.
2. Lower sliding sash so that latch enters large notch covered by block removed in Step 1.
3. With latch in large notch, push finger holds outward until inside edge is exposed. Pull latch out of finger hole opening.
4. Finger latch is pried off attached metal latch with any tool that provides leverage. Latch may now be removed and replaced.
5. Reassemble by reversing procedure.

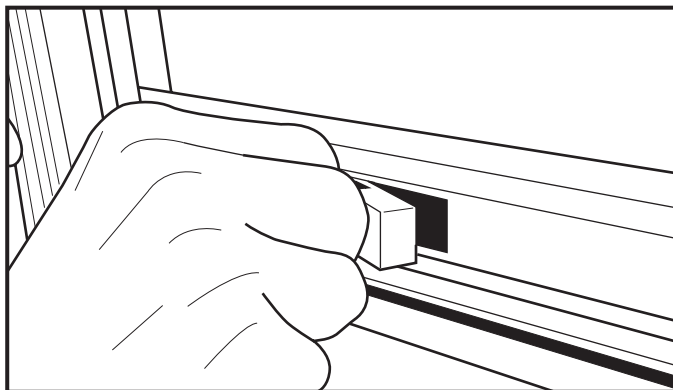

Step 3

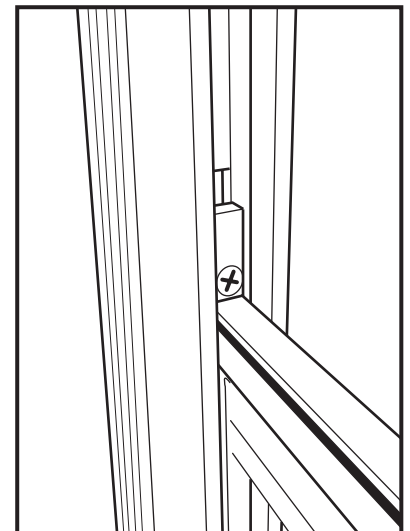

Step 1

**NOTE:** Lubricate latches and sliding seal of top window with silicone spray every 30 days. See decal on driver's window.

### ENTRANCE DOOR GLASS REPLACEMENT

1. Apply pressure against glass from the outside of the bus, starting at a corner and push glass and glazing rubber off of metal flange.
2. Remove glazing rubber from around glass.
3. Put glazing rubber on new glass.
4. Wrap a cord around the glazing rubber and rest the glass on the bottom flange of the opening from outside the bus.
5. Pull cord slowly and work glazing rubber onto metal flange.
6. Apply pressure to glass from inside of bus to assure proper seal.

**WARNING: When replacing broken or damaged glass, use extreme care at all times to prevent personal injury. This includes the use of proper replacement parts, tools and personal protective equipment, such as gloves and safety goggles.**

### **REAR VISION GLASS REPLACEMENT**

1. Remove filler strip from channel in glazing rubber.
2. Apply pressure against glass from the outside of the bus starting at a corner and push glass and glazing rubber off of metal flange.
3. Remove glazing rubber from glass.
4. Put glazing rubber on new glass.
5. Apply a soapy solution to the flange on the bus body and to the filler strip channel on glazing rubber. This acts as a lubricant for easier installation. Wrap a cord around the glazing rubber and rest glass on bottom window flange from the inside of the bus body.
6. Apply pressure from the inside of the bus body to insure glass is seated properly. Pull cord slowly and work glazing rubber onto the window flange.
7. Using filler strip tool, insert filler strip into channel on glazing rubber. (Filler strip tool is available from your distributor.)
8. Apply clear caulking around glass and window flange on the outside of bus body to insure that no leaks occur.

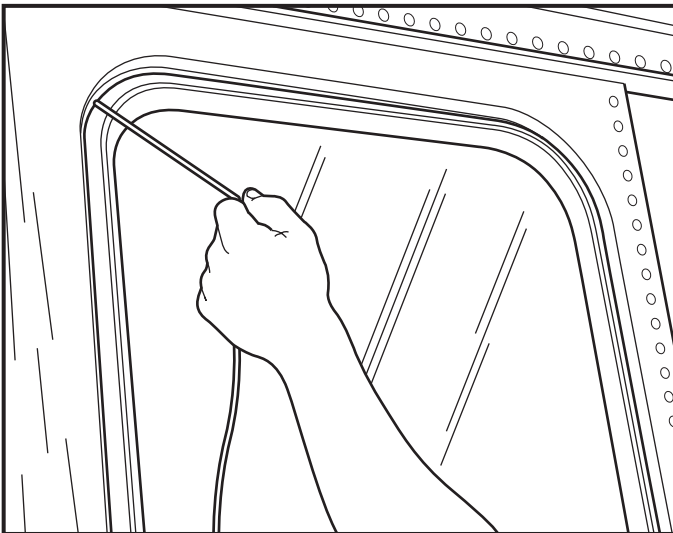

Step 6

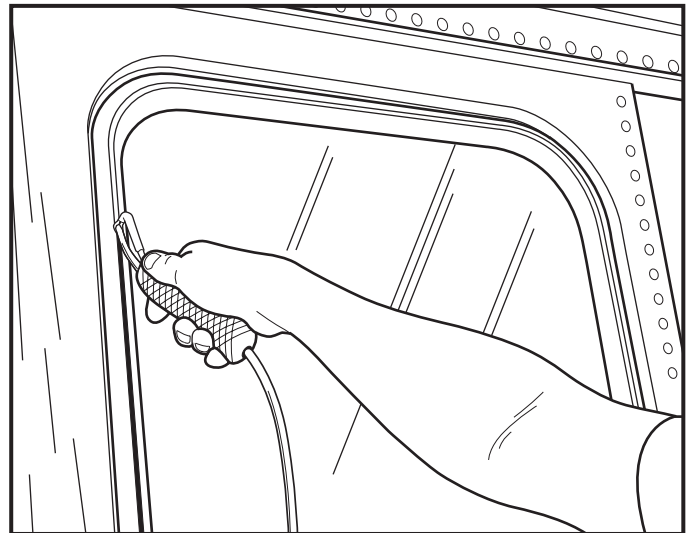

Step 7

# WINDSHIELD WIPERS

## WIPER ASSEMBLY REPLACEMENT

To replace wiper assembly (Blue Bird No. 0348144), loosen lock nut, remove screw and pull wiper assembly loose from wiper arm. Replace the wiper assembly and use original screw and lock nut. Tighten lock nut securely, but do not tighten enough to compress the saddle. Blade must be free to move on axis (machine screw) and within the saddle. Threading the lock nut until flush with machine screw end will give a secure and serviceable installation.

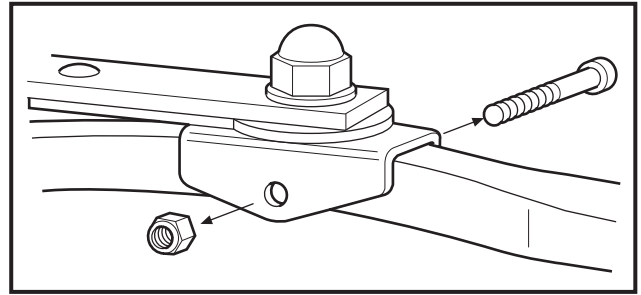

## WIPER REFILL REPLACEMENT

To remove wiper refills, follow the procedure outlined below.

1. Lift end clip with screwdriver as shown in. This releases locking indentations (A) and allows end clip retainers (B), to be removed through blade claw.
2. Repeat procedure to remove retainer clip on opposite end of wiper.
3. New end clips are provided with replacement Anco refills. To install, remove one clip and slide the refill through all claws until end clip locks into place.

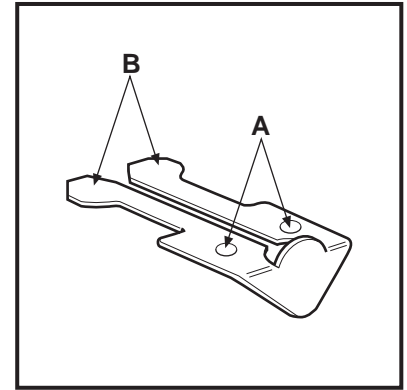
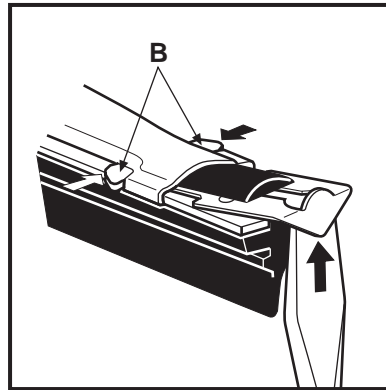

4. Install second end clip, snap-locking devices A and B into place to secure refill.

# LOWER SIDE PANEL REPAIR PROCEDURE

1. Remove the lower portion of the side panel by carefully drilling out the vertical rows of rivets on each side of the panel from the bottom of the floor line rub rail to the bottom of the skirt and the rivets attaching the bottom rub rail to the panel to be removed. Cut the panel not less than one inch below the floor line rub rail and remove.
2. Clean to bare metal the one-inch wide section of panel left below the floor line rub rail and apply a one-inch wide bead of Amicon two-component epoxy, TX-4009 or equivalent, following directions and recommendations of the adhesive manufacturer.
3. Insert the replacement panel between the rub rail and the original side panel far enough to insure a minimum of 1/2 inch of the replacement panel is under the rub rail. Install Cherry SSPV 86 blind rivets, Blue Bird P/N 0888222 on 3 1/2 inch centers through the rub rail lower flange and the new and old side panel.
4. Replace the vertical rows of rivets and the rivets attaching the bottom rub rail with the same type, size, and quantity of fasteners as was used in the original construction or with Cherry SSPV 86 blind rivets, Blue Bird P/N 0888222, as necessary.
5. Allow the adhesive to cure the proper amount of time (fourteen days at room temperature for the Amicon TX-4009) before returning the vehicle to service.

## DRAIN HOLES

There are two drain holes located in each floor section. One right hand side under window and one left hand side under window. These holes should be cleared of all debris quarterly to allow for water drainage.

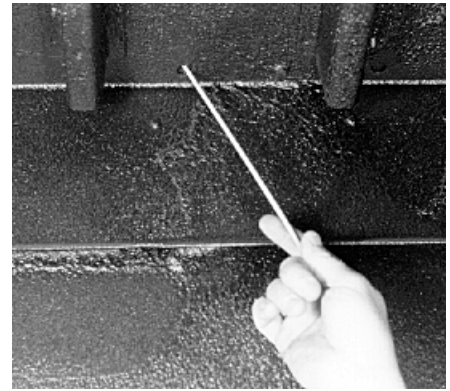

## WARNING LIGHT DOOR SWITCH ADJUSTMENT

Warning light door switches should be checked at least once a year to see if they are securely tightened and adjusted correctly.

Remove four screws securing cover. Adjust switches so that when the door is closed the switch button in depressed position should extend no more than .06 past the bezel surface as shown but never flush with the bezel surface.

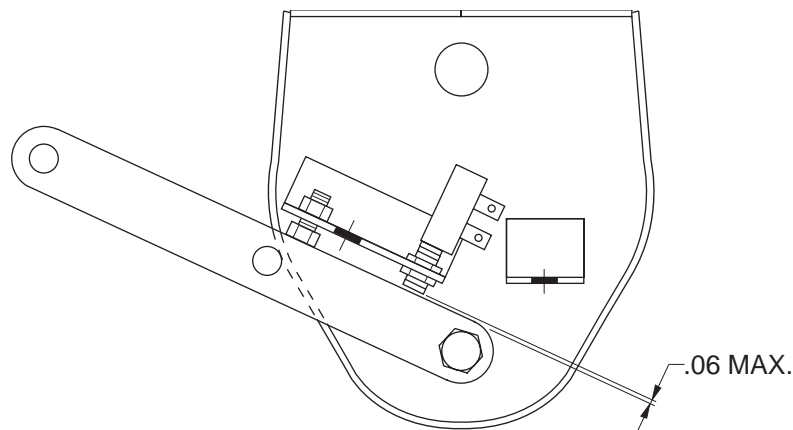
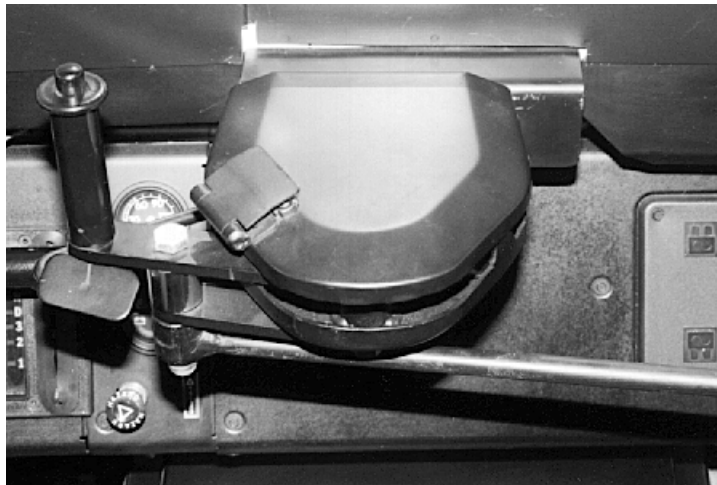

## SPARE TIRE LOCATION & REMOVAL

If your unit is equipped with a spare tire compartment, the following procedure should be used to remove and replace spare:

1. Unlatch the tire compartment door and secure in the open position with the chain and hook.
2. Pull out the rack.
3. Remove the wheel hold down clamp and lift off the wheel. Reverse the procedure above to replace the wheel.

**WARNING: At all times stay from beneath tire.**

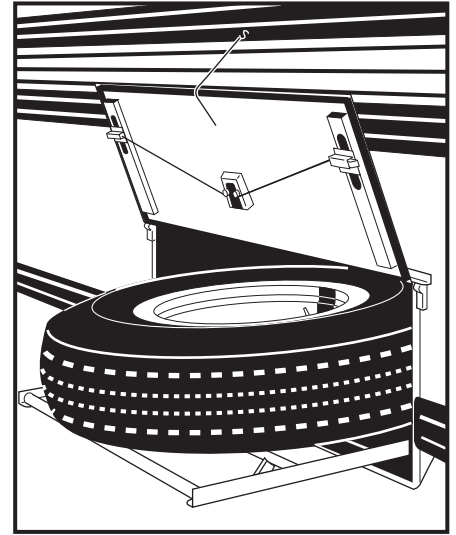

## COMPRESSED NATURAL GAS

### INTRODUCTION

The compressed natural gas (CNG) fuel system consist of DOT certified storage tanks that store CNG at up to 3600 psi that replace the fuel tank, a structure to hold and protect the tanks, metallic fuel lines to deliver the fuel, high and low pressure regulators to reduce the pressure entering the throttle body, a fuel shut-off solenoid and the throttle body which delivers the CNG/air mixture to the engine. The regulator includes an integral heater to preheat the CNG for anti-icing control.

A pressure relief system is part of the fuel system. This system is designed to vent the tank contents when pressure and temperature become excessive.

A fill connection is located near the entrance of the bus.

If so equipped, the engine powering this bus is engineered specifically for use with CNG. Operation and maintenance procedures are similar to those used on gasoline or diesel engine vehicles. Differences identified are obvious.

### OWNER / OPERATOR RESPONSIBILITIES

The owner/operator should be aware of the code requirements and be familiar with applicable codes which apply to the area of operation. The owner/operator should be aware that fuel cylinders for CNG (Compressed Natural Gas) must be inspected every three (3) years in accordance with NGV-2 specifications. The owner/operator should be aware that cylinder expiration date is fifteen (15) years after date of cylinder manufacture and that cylinders must be replaced. This testing and certification is not covered by Blue Bird warranty.

**WARNING: Due to the dangerous potential of high pressure cylinders, it is suggested that anyone involved in their use be completely familiar with the Department of Transportation "Code of Federal Regulations Title 49" and the various Compressed Gas Association pamphlets that are available covering the care and use of high pressure cylinders. Regulations do not permit filling NGV cylinders with an over-charge.**



## **NATIONAL FIRE PROTECTION ASSOCIATION #52 states:**

Cylinders shall be manufactured, inspected, marked, tested, retested, equipped and used in accordance with U.S. Department of Transportation (DOT) or Canadian Transport Commission (CTC) regulations, exemptions or special permits specifically for CNG service and shall have a rated service pressure of not less than 2400 psig at 70 Deg. F. (16.5 MPa at 21.1 Deg. C).

Pressure vessels shall be manufactured, inspected, marked and tested in accordance with the rules for construction of unfired pressure vessels, Section VIII (Division 1), ASME Boiler and Pressure Vessel Code.

When a vehicle is involved in an accident or fire causing damage to the CNG container, the CNG container shall be replaced or removed, inspected and retested in accordance with the document under which it was originally manufactured before being returned to service.

When a vehicle is involved in an accident or fire causing damage to any part of the CNG fuel system, the system shall be retested before being returned to service.

Damaged supply lines shall be replaced, not repaired.

The owner or user or both shall maintain all containers, container appurtenances, piping systems, venting systems and other components in a safe condition.

As a precaution to keep pressure relief devices in reliable operating condition, care shall be taken in the handling or storing of compressed natural gas containers to avoid damage. Care shall also be exercised to avoid plugging by paint or other dirt accumulation of pressure relief device channels or other parts which could interfere with the functioning of the device. Only qualified personnel shall be allowed to service pressure relief devices. Only assemblies or original manufacturer's parts shall be used in the repair of pressure relief devices unless the interchange of parts has been proved by suitable tests.

## **CODE OF FEDERAL REGULATIONS #49 states**

In addition to the requirements of this paragraph, cylinders marked DOT-3HT must be requalified in accordance with CGA pamphlet C-8 and must comply with the following:

Cylinders built prior to implementation of FMVSS 304 must be subjected, at least once in three years, to a test by hydrostatic pressure in a water jacket, for the determination of the expansion of the cylinder. A cylinder must be condemned if the elastic expansion exceeds the marked rejection elastic expansion.

Cylinder service life must not exceed 15 years.

Each cylinder must be reinspected and hydrostatically retested every three years in accordance with 49 CFR 173.34(e) as prescribed for DOT-8HT cylinders, except that the rejection elastic expansion criteria does not apply, permanent volumetric expansion must not exceed 5 percent of total volumetric expansion at test pressure and retest dates must be imbedded in the epoxy coatings in a permanent manner other than stamping. Retest dates may be steel stamped on the shoulder of the top head in accordance with 178.BB-15(c). Reheat treatment or repair of cylinders not authorized.

## **FUEL SYSTEM DESCRIPTION**

The fuel system begins with DOT certified tanks to hold compressed natural gas (CNG) up to 3600 psi, corrected to standard day temperature. The tanks are high strength aluminum wrapped with fiberglass for further strength.

The fuel exits the tank in route to the engine through manually controlled shutoff valves. These include an integral pressure relief valve consisting of a combination rupture disk (for pressure) and fuse plug (for temperature) to vent the contents of the tank should high pressure and high temperature occur, such as in a fire. The rated pressure and temperature for relief is 212 degrees Fahrenheit.

From the valve fuel flows into a common fuel line through high pressure stainless steel compression fittings. The tanks are joined to the common line through high pressure stainless steel tee's and crosses. Any open tank thus communicates to any other open tank. So for fueling, the fuel is backfed through the common line to all tanks (with open valves) simultaneously. The tank shutoff valves only isolate the interior of the tanks: The tee's on the valves still have the high line pressure.

Do not uncouple fittings until all tanks are closed and pressure has been purged from the line.

The lines are high pressure rated 3/8 stainless steel seamless tubing which carries the fuel to the high pressure regulator.

In refilling, the fuel enters the fill valve on the entrance side of the bus and then flows through a check valve into the common tubing before reaching the tanks.

From the high pressure regulator, the fuel flows to the shutoff solenoid. The shutoff solenoid is activated by the ignition switch, engine operation, and the fire suppression system. The loss of any of these will shut off fuel supply to the low pressure regulator (LPR).

The dashboard fuel gauge is proportional to the pressure when corrected to 70 degrees Fahrenheit.

**NOTE:** Fuel level is only accurate for the tanks that are open.

## **SAFETY CAUTIONS & WARNINGS**

Both gasoline and CNG are volatile flammable fuels that are safe to work around when necessary precautions are taken. As on a gasoline fueled system, carelessness with CNG can lead to a fire or explosion when a leak occurs. CNG will not pool and spread like gasoline. It has a narrower range of flammability than gasoline as well as a higher ignition temperature. Despite these relative safety advantages, fire potential does exist. CNG is lighter than air, therefore, it can collect in the higher regions of a room and possibly go undetected, creating fire potential.

Since the fuel system is a very high pressure system employing a flammable gas, all safety issues normally considered in these situations should be applied. Some of the more obvious precautions are listed below. This list is not necessarily intended to be complete, and responsibility for assuring full safety is that of the person(s) doing the work or operating the system.

**WARNING: Handle natural gas with care. Compressed natural gas is a volatile fuel stored under high pressure. If fuel storage or delivery components are installed, serviced or operated improperly, fire, explosion and/or serious injury could result. Do NOT smoke while working on or around natural gas equipment. Avoid flames, sparks and operation of electrical devices in or around a vehicle with a possible natural gas leak. Properly tighten all connections and thoroughly check for leaks after servicing fuel system. Natural gas fumes may cause sickness or death. Work in well ventilated area.**

**WARNING: Protect against high pressure CNG. Compressed natural gas is stored and routed to the engine at a pressure up to 3600 psi. Do NOT attempt to remove or disassemble any fuel system component while it is pressurized. Explosive separation of components and escaping natural gas can cause serious injury. Avoid the hazard by relieving pressure before disconnecting any CNG fitting or line. Properly tighten all connections and thoroughly check for leaks before applying pressure. Never attempt to over pressurize the system.**

**WARNING: Protect against extremely cold escaping CNG. Compressed natural gas is stored at an extremely high pressure. If compressed natural gas escapes from a leak, it will expand into and extremely cold (-260 deg F) gas. Severe frost bite may occur from contact with escaping natural gas or its associated components. Avoid the hazard by relieving the pressure before disconnecting any CNG fitting or line. Properly tighten all connections and thoroughly check for leaks before applying pressure.**

**WARNING: Storage tanks must be tested according to specified procedures at required dates. Failure to do so relieves the manufacturer of all responsibility and is a violation of federal law. See manufacturer's label.**

**CAUTION: In the event of an accident, all tanks, lines and fittings should be thoroughly checked by qualified personnel before the vehicle is used again.**

**NOTE:** All valves are closed when turned fully clockwise viewed from the top of the valve handle, and open when turned counterclockwise viewed from the top of the valve handle.

**CAUTION: Always provide good ventilation, including near roofs and ceiling.**

**CAUTION: Do not work in a noisy environment, the sound of leaking gas may go undetected.**

**WARNING: Never attempt to find a leak with your hands. A large leak can freeze burn the skin.**



**WARNING: Never place hands or any other part of the body on a leak.**

**IMPORTANT:** Always have rated fire extinguishers on hand and automatic fire suppression equipment.

**CAUTION: Avoid heat near pressure relief valves; the manufacturer's rating is 212 degrees Fahrenheit for the relief valve. Should it vent, the entire area will be filled with natural gas.**

**IMPORTANT:** Rust or corrosion on tanks, lines, fittings and valves can be a serious problem. Any part with serious corrosion should be replaced.

**IMPORTANT:** Fiberglass coating on tanks should be in excellent condition. Any cracks or serious scrapes may require tank replacement. Contact the manufacturer.

**WARNING: Tanks cannot be filled to more than 3000 psi or 3600 psi temperature corrected.**

**IMPORTANT:** Use only authorized refueling stations with adequate pressure controls and venting capacity.

**NOTE:** Venting contents of tanks should follow any federal and state guidelines, including EPA.

**WARNING: Use only fuel connections designed for use with that on the bus. Do not attempt to force damaged fittings.**

**WARNING: Keep sources of heat and ignition away from fuel system and refueling apparatus.**

For more information see drawing #1589001 in the owners information package supplied with the vehicle.

## **COMPRESSED NATURAL GAS FUEL**

The performance and reliability of a Natural Gas Vehicle is dependent upon the quality of fuel used. BTU content of natural gas can vary depending on locale. Excessive moisture can cause driveability problems, loss of power and regulator freezing. Other contaminants, specifically lubricants and oil, can cause serious damage which is not covered by the engine manufacturer's warranty. In addition, poor quality fuel can affect emission certification.

**CAUTION: It is the owner's/operator's responsibility to insure that clean, quality fuel is used to prevent damage to the fuel system components and power plant. Damage caused by poor quality fuel is not covered by Blue Bird warranty.**

Fuel control systems used on engines fueled by compressed natural gas contain electronic sensors and other delicate components which are not tolerant to contaminants. Vehicle performance is dependent upon clean fuel and regular scheduled vehicle maintenance.

Compressed natural gas is expected to be delivered from the compressor station and storage cascade free of contaminants including oil, water, and particulates.

Conditions exist in some CNG fill stations that cause inferior fuel to be loaded in the vehicles fuel storage system.

The driving range of a natural gas vehicle is dependent upon driver, fuel BTU content, vehicle weight, gear ratio, tire size, terrain, engine tune and condition, frequency of starts and stops, full load of fuel and other factors.

## **COMPRESSED NATURAL GAS FILTERS**

Particulate and coalescer type filters are installed in Blue Bird CNG fuel systems. The primary filter is of stainless steel construction and is located at the fill point. This filter can be checked for contamination by closing main shutoff valve on frame and then relieving pressure which is trapped between the check valve in the fill nozzle and the main system check valve. The owner/operator should establish a service interval based on quality of gas from the compressor station. It is recommended that the filter sump be checked after the initial fill and several fills after and then develop a schedule based on need; every fill or every fifth fill or longer.

The secondary filter has a black anodized housing and is adjacent to the fuel shutoff solenoid close to the engine. The secondary filter can be checked after relieving system pressure. This is best accomplished by closing the main shutoff on frame and running engine until fuel supply is depleted and pressure is zero. Contamination of the secondary filter should not occur if a proper maintenance schedule has been followed at the fill point primary filter. Contamination of the secondary filter also shows that CNG storage cylinders on the vehicle are contaminated. The owner/operator should insist that fuel from a compressor station should be clean and dry.

Replacement filter elements are available through the Blue Bird Service Department.

**WARNING: Natural gas is extremely flammable and high pressure gas can cause personal injury, loss of sight, or death.**

## **FUEL COMPOSITION**

Natural gas composition varies throughout the country, depending on original gas composition and processing. Pipeline quality natural gas is composed of several different gases, of which methane typically accounts for 85 to 99%. Other hydrocarbons present in natural gas include ethane, propane, some butanes, and trace amounts of other hydrocarbons. Nitrogen, helium, carbon dioxide, and trace amounts of hydrogen sulfide, water, and odorants are also present. Most natural gas available does not vary significantly in content; however, significant variations are more likely from small gas utilities. The removal of all carbon dioxide, water, hydrogen sulfide, and odorants is required for liquefaction, thus LNG does not contain these constituents.

The importance of gas composition to users of NGVs is as follows:

Large amounts of non-methane hydrocarbons will enrich the fuel mixture, reduce the octane number, lead to increased hydrocarbon emissions, and increase the potential for engine knock. Accordingly, engine parameters such as air/fuel mixture and ignition timing should be adjusted on the basis of the composition of the local natural gas supply.

## **REFUELING**

**CAUTION: Refueling must be conducted in well ventilated areas to prevent accumulation of dangerous gas levels.**

The National Fire Protection Association has recommended guidelines for CNG refueling systems. State and local regulation regarding NGV refueling may preclude economic feasibility of indoor refueling (such as in New York City). However, the significance of this issue may diminish if increased experience with fuel leads to less stringent regulations.

CNG refueling transfers natural gas under pressure and may be set up as either slow-fill or fast-fill. Slow-fill generally uses overnight refueling and requires less costly refueling station equipment than fast-fill. However, fast-fill refueling time is only slightly longer than gasoline refueling time. LNG refueling transfers a cold (-260°F) liquid under pressure (around 15 psi) and generally takes slightly longer than conventional refueling because a greater volume of liquid is transferred to compensate for its lower energy content.

The refueling station has a supply connection hose and a coupling which must be properly attached to the fuel system fill valve. The supply side is regulated for maximum pressure and uses a proper purge valve when decoupling from the filler. The regulators and relief valves of the fill station must be checked for proper values and operation.

Fuel enters the bus coupling from the filler connection, travels through a one-way check valve into the fuel lines and then into any open tanks. Any tank that is open is in communication with any other open tank through the common fuel lines.

**CAUTION: Do not refill with the engine running or any source of ignition or heat nearby. The refueling station must be in a safe working condition with approved operable relief and vent valves.**

**NOTE:** A ground stud is provided for attachment of the grounding cable at the compressor station. Check that the tank shutoff valves are open. Any tank with an open valve will be filled, any tank with a closed valve will not. If the bus has been operating with some tanks closed, it is preferable to fill the empty tanks first and then fill the remainder. Fill to the desired pressure. Maximum is 3000 psi temperature corrected to 70 degrees Fahrenheit. (**NOTE:** Most fill stations have a dome valve to automatically make the temperature correction.) When fueling is complete, open the fill connector purge valve. Use only fuel filling couplings designed for use with the CNG. Do not force damaged couplings together.

**CAUTION: A check valve is included in the system behind the fill connector to prevent backflow of fuel when purging and disconnecting the fuel nozzle**

**NOTE:** The tanks are full at 3000 psi or 3600 psi and 70 degrees Fahrenheit. The pressure will vary with temperature. Decreasing with lower temperature and increasing with higher temperatures. Filling apparatus compensates for the temperature effect.

**WARNING: Never fill to more than permissible pressure. Contact the manufacturer if an accidental overflow occurs.**

**NOTE:** The fuel level is only accurate for tanks that are open. For example, if one tank is open and reads 1000 psi, then the fuel available to the engine is proportionate to the total capacity.

### SPECIFIC GRAVITY

The specific gravity of natural gas relative to air (air=1.00) is 0.56 to 0.62 depending on gas composition. This indicates that natural gas is lighter than air. In the event of a natural gas leak, the gas will rise and dissipate given open conditions. There is no possibility of CNG accumulating in pools on the ground beneath a spill.

**NOTE:** Natural gas odorants allow its detection by humans before dangerous concentrations are reached.

In the case of LNG releases, the cold vapor initially released is heavier than the surrounding warmer air and thus stays low, near the ground (a visible vapor cloud is often formed from the condensation of water in the cold air-gas mixture). As the vapor cloud warms, it will increase in volume, become lighter than air, and rapidly dissipate.

### FUEL TOXICITY AND SAFETY

Natural gas is a nontoxic gas. It is flammable under proper conditions. Additionally, it can cause suffocation if enough oxygen is displaced. LNG has the added safety concern of being a cold (-260°F) liquid under pressure. Severe frostbite may occur from contact with LNG or associated cold components. Furthermore, many common materials change their strength characteristics when exposed to LNG temperatures, thus presenting additional hazards.

**WARNING: LNG tanks have the potential for explosions under circumstances such as those described for LPG explosions.**

Although natural gas has odorants to aid in detection of leaks, these odorants are removed during liquefaction, thus LNG vapors can not be detected by smell. (**NOTE:** LNG odorants have been developed but are not commonly used due to the relatively restricted use of LNG at this time).

### FLAMMABILITY

Autoignition temperature for natural gas at atmospheric pressure is 1004°F compared to an autoignition temperature range of 442 to 880°F for gasoline and approximately 500°F for diesel fuel. The risk of fire in the

presence of an ignition source exists when the ratio of air to fuel is within flammability limits (i.e., fuel can not ignite if it is mixed with too much or too little oxygen). The flammability limits for natural gas are 5.3 to 15% volume of gas in air. For comparison, the flammability limits of unleaded gasoline are 1 to 7.6% volume of gasoline in air. As a practical matter, there is no oxygen present in CNG cylinders or LNG tanks, therefore ignition within the cylinder or tank is not possible. In the event of fuel leak, there will be a small area in which the air to fuel ratio is within the flammability limits. In a closed garage, or within the passenger compartment, ignition conditions are more likely to be met. Odorants used in CNG allow its detection before the lower flammability limit has been reached.

### **ANTI-KNOCK PROPERTIES**

Natural gas has a research octane rating of about 130, making it relatively resistant to engine knock. The antiknock property is a result of the high ignition temperature, resistance to autoignition, and the relatively low flame speed of natural gas. Antiknock properties allow the use of engine compression ratios in the range of 15:1 (compared to 8:1 to 10:1 for gasoline). The low flame speed of natural gas results in a longer duration of combustion. To compensate for the lower flame speed, ignition timing is advanced. As with other fuels, knock may occur with advanced ignition timing, prolonged combustion (i.e. too lean mixture), and excessively high compression ratios.

### **ENERGY CONVERSIONS**

- 100 - 125 cubic feet NG = 1.0 gallon gasoline
- 136 cubic feet NG = 1.0 gallon diesel
- 1 cubic foot NG = 1000 Btu
- 114,000 Btu = 1.0 gallon gasoline
- 83,700 Btu = 1.0 gallon LNG

### **VEHICLE PERFORMANCE AND EMISSIONS**

NGV performance, fuel economy, and emissions can be significantly altered with vehicle tuning (e.g., ignition timing, air/fuel ratio). Appropriate tuning adjustments can optimize either performance, fuel economy, or emissions. Alternatively, a compromise tuning may be effected. Tuning optimization for power generally increases emissions. Substantial improvements in performance and emissions can be obtained using natural gas conversion kits that are specially designed for a given vehicle make and model. Further improvements can be achieved with factory built, dedicated NGVs.

### **STARTING PROCEDURE**

Make sure that the main shutoff valve and at least one tank valve are open. The fuel gauge shows empty if no fuel is available to the mixer. Check the tank and main fuel shutoff valves if no fuel is indicated on the fuel gauge.

**NOTE:** Fuel gauge takes time to register after turning the key.

Starting procedures are identical to those of a gasoline engine vehicle. With the vehicle in neutral, turn the key until the engine catches. Do not press the accelerator. If the engine has trouble starting depress the accelerator slightly and release when the engine catches. Pumping the accelerator in no way assists in starting the engine.

Engine operation and characteristics should be similar to those of a gasoline engine.

### **COLD START**

For cold starts in low ambient temperatures, natural gas has an advantage over liquid fuels because it is already in the vapor phase. With correct conversion kit installation and vehicle maintenance, cold start ability is better with natural gas than gasoline.

## OPERATION & MAINTENANCE of VEHICLE COMPONENTS

CNG vehicles require Department of Transportation (DOT) certified cylinders for the storage of pressurized (maximum 3600 psi) natural gas. Refueling port and lines with pressure safety valves must also be installed. High pressure fuel lines from the storage cylinder lead to a pressure regulator/reducer, which reduces gas pressure in one or two steps. In a fuel injected converted vehicle, a mixer/carburetor must be added for the injection of natural gas. In carbureted fuel systems, a specialized mixer/carburetor for natural gas may be installed. LNG vehicles require insulated, pressurized (10 to 35 psi) fuel tanks. LNG is vaporized in the fuel line and warmed in the heat exchanger generally located under the hood. Pressure is reduced by the pressure regulator before the vapors are transported to the mixer/carburetor.

## MAINTENANCE

Service manuals supplied by converters and installers should be consulted for maintenance of NGV-specific parts. Components such as the pressure regulator/reducer can be checked with a pressure gauge to determine if the unit is operating properly. Measurements with an EGA can indicate proper air/fuel mixtures and ignition timing. NGV maintenance issues are briefly listed below.

**CNG Cylinders** - CNG cylinders must periodically be recertified to maintain compliance with DOT standards. The Compressed Gas Association has published several pamphlets with recommendations of standards for the inspection of compressed gas cylinders.

**Oil Changes** - Due to the clean burning characteristics of natural gas, collection of particulate matter in engine oil does not occur as rapidly as with gasoline. However, even though visual inspection of the oil may indicate that the oil is clean, oil compounds break down under engine heat. These chemical changes reduce the lubricating ability of the oil and stress the engine system. Therefore, it is recommended that the oil should be changed according to manufacturer recommendations, despite oil appearance. (**NOTE:** Considerably more data is needed to determine the conditions that influence reports of NGV oil maintaining lubricating properties longer than in gasoline engines.)

**Spark Plugs** - Spark plugs should be replaced as recommended by the vehicle manufacturer.

**CAUTION: Do not use CNG pressure or vent lines to clamp, hang, connect or attach any items including harnesses, hoses, power steering hose, refrigerant hoses or any other item.**

## SCHEDULED MAINTENANCE

---

### MONTHLY OR 1,000 MILES

- Grease safety barrier latch on Braun wheelchair lift.
- Lubricate roof hatch weatherseals & lock mechanisms.
- Inspect all emergency equipment mounting fasteners.
- Lubricate window latches and slides.
- Lubricate hinge pin on entrance doors.
- Lubricate pivot points on outward opening door.
- Check/adjust roller bracket and control rod bracket on jackknife door.
- Check/adjust air pressure in power jackknife door.
- Inspect outer fasteners and lubricate electric stop arms.
- Inspect seat frames for secure attachment to the floor and wall.
- Inspect front heater air filter. Clean if necessary.
- Check and adjust all mirrors as required.
- Lubricate rear emergency door positive hold open hinge.



### **3 MONTHS OR 5,000 MILES**

- Inspect mounting bolts on body tie down.
- Inspect mounting fasteners and upholstery on seats.
- Lubricate bridge plate hinge and pivot on Collins wheelchair lift.
- Clean and lubricate fold cam slot, platform cam slots and handrail V-block on Collins wheelchair lift.
- Check fluid level in Collins wheelchair lift.
- Lubricate hinge and latch mechanisms on access doors.
- Check internal fasteners on electric stop arms.
- Lubricate entrance door vandal lock.
- Inspect heater valves to verify proper function.
- Inspect fire extinguisher to see if fully charged.
- Check first aid kits to see if fully equipped.
- Oil all hinges and window latches for ease of operation.
- Lubricate all window channels with silicone or graphite.
- There is one drain hole in each floor section under windows. Be sure hole is clear of debris so any water may escape.
- Clean all rubber door seal and lubricate with rubber lubricant.
- All rear and side emergency door latch slide bars to be lubricated with light grease to reduce friction.
- Tighten all body tie down bolts at 1,000 miles, 2,000 miles, and quarterly thereafter.
- Clean heater air filter.

### **3 MONTHS OR 24,000 MILES**

- Check for loose or disconnected electrical connections and damaged wiring.

### **6 MONTHS OR 6,000 MILES**

- Lubricate entrance door vandal lock.
- Check/adjust emergency door vandal lock.
- Lubricate lock mechanism and door hinge on emergency door.
- Inspect destination sign for proper operation.
- Lubricate hinges and roller gears on destination signs.
- Check/adjust curtain on destination signs.
- Lubricate all working part joints on driver's seat using lithium-based grease (aerosol).
- Check/adjust door control rod on manual entrance doors.

### **12 MONTHS OR 12,000 MILES**

- Check cylinder chains, hoses and wires on the Braun Wheelchair lift.
- Check heater hoses, motor wheels and fans on heaters.
- Clean heater cores.
- Tighten heater hose clamps.
- Check heater panels and housing.
- Complete Quarterly Maintenance Check List.
- Remove all seat cushions, thoroughly clean with upholstery cleaner, and reinstall on a rotating basis.
- Adjust door control rod and closing mechanism to entrance doors.
- Bleed all air from heaters.

These check lists are suggested. They do not replace or supersede local or state required driver inspection procedure.

# QUICK REFERENCE MAINTENANCE CHARTS

## BODY COMPONENT MAINTENANCE CHART

Operation	Service Intervals *							Months / Miles Whichever Occurs First
	1 / 1,000	3 / 5,000	3 / 24,000	6 / 6,000	6 / 10,000	12 / 12,000	12 / 24,000	24 / 24,000
								*Service Intervals to be performed on a continuing basis. Example: 1 / 3,000 means every month or every 3,000 miles.
								<b>General Instructions</b>
<b>OUTWARD OPENING DOOR</b>								
Adjust Door Linkage Rod	As Required							Adjust door linkage rod for proper open/closed position.
<b>JACKKNIFE DOOR</b>								
Adjust Door Control Rod				●				Adjust door control rod for proper open & closed position. See page 34 & 35.
Adjust Roller Bracket	●							Adjust roller bracket for easier door operation. See page 34 & 35.
Adjust Control Rod Bracket	●							Adjust bracket to prevent pivot pin binding. See page 34 & 35.
Lubricate Hinge Pin	●							Lubricate each hinge lug. See page 34 & 35. Use LPS No. 1 lubricant.
<b>POWER JACKKNIFE DOOR</b>								(IF SO EQUIPPED)
Lubricate Hinge	●							Lubricate hinge pin. Use LPS No. 1 lubricant.
Adjust Air Pressure	●							
<b>AIR STOP ARM</b>								
Lubrication								No lubrication required.
Adjustment	As Required							Adjust air pressure for proper opening and closing of stop arm.
<b>ELECTRIC STOP ARM</b>								
Lubrication	●							Lubricate breakaway hinge at four (4) pivot points. Use Tri-Flow™ (Dupont) lubricant.
Inspect Outer Fasteners	●							Check outer fasteners for tightness.
Inspect Internal Fasteners		●						Check inner fasteners for tightness.
<b>VANDAL LOCKS</b>								
Lubricate Entrance Door				●				Lubricate bushing & shaft in center at base of lock handle. See page 36. Use "Apply"™ lubricant.
Lubricate Entrance Door Key Lock		●						Spray lubricant into key lock. Use "Apply"™ lubricant.
Lubricate Sliding Bolt		●						Lubricate sliding bolt mechanism. Use LPS No. 1 lubricant.
Inspect & Adjust Emerg. Door		●						No lubrication and adjustment required.
<b>BUS BODY CARE</b>								
Wash	As required							See page 37.
<b>EMERGENCY EXITS</b>								
Lubricate Lock Mechanisms				●				Spray lubricant into lock mechanism. Use Silicon spray.
Lubricate Roof Hatch	●							Spray silicon lubricant into lock mechanism. Work lock handle back & forth to insure smooth operation. See page 30. Use Silicon spray.
Lubricate Door Hinge				●				Spray lubricant into hinge lugs. Use LPS No. 1.
Lubricate Rear Emerg. Door Positive Hold Open Hinge	●							Grease with door closed. use low temp grease per ASTM D4950 GC-LB Grade 2. -60 deg. to 350 deg. F. One fitting per hinge
<b>EMERGENCY EQUIPMENT</b>								
Inspect All Mounting Fasteners	●							Inspect all emergency equipment mounting bracket fasteners to insure tightness.
<b>DESTINATION SIGNS</b>								
Lubricate Hinges				●				Lubricate all hinge lugs. Use lightweight lubricating oil.
Lubricate Roller Gears				●				Lubricate roller gears where required. Use lightweight grease such as (White Lube).
Check & Adjust Curtain				●				See page 7.
Replace Bulb	As Required							
<b>WINDOWS</b>								
Lubricate Latch	●							Spray lubricant into window latch mechanism. Use Silicon spray.
Lubricate Window Slides	●							Spray lubricant into sliding frame of window. Use Silicon spray.



# BODY COMPONENT MAINTENANCE CHART

Operation	Service Intervals *								Months / Miles Whichever Occurs First
	1 / 1,000	3 / 5,000	3 / 24,000	6 / 6,000	6 / 10,000	12 / 12,000	12 / 24,000	24 / 24,000	General Instructions
<b>HEATERS</b>									
Check Heater Hoses						●			Check hoses for kinks, cracks or other visible signs of damage. See page 42.
Clean Heater Coil & RH Front Heater Air Filter						●			Keep air flow passage free of dust & dirt by cleaning w/compressed air or vacuum & a soft bristle brush. Straighten damaged fins with a fin comb. See page 42.
Check Motor Wheels & Fans						●			Check wheels and fans for obstructions or damage by running each fan alone, then listen and feeling for irregularity. Replace damaged wheels or fans to prevent vibratory damage.
Check Heater Panels & Housing						●			Fasteners which connect and retain structural & access panels should be checked and tightened as necessary.
Tighten Heater Hose Clamps	1st 1,000 Miles and Annually Thereafter								Heater hose clamps are located at the underseat heater coil, behind the access door in the heater hose covering immediately forward of the left front wheelhousing & under the floor near right front and driver's heaters.
<b>BODY MOUNTING</b>									
Inspect Mounting Bolts	●								See page 33.
<b>MIRRORS</b>									
Adjust Mirrors	As required								Loosen adjusting nuts, make adjustment, then retighten nuts.
<b>SEATS</b>									
Inspect Mounting Fasteners	●								Tighten fasteners if required.
Inspect Cushion Attachments	Weekly								Tighten with Phillips-head screwdriver, if required.
Inspect Upholstery	●								Inspect for cuts, tears, wear and soiled areas.
Lubricate Driver's Seat			●						Apply lubricant to all working part joints. Use Aerosol Lithium base grease.
Inspect Seat Belts	Weekly								Inspect for torn or frayed areas.
Inspect Seat Belt Buckles	Weekly								Inspect for adjustability and proper operation.
Lubricate Seat Belt Buckles	As Required								Lubricate buckles to insure ease of operation. Use Graphite-type lubricant.
Clean Seat Belt Webbing	As Required								Clean using warm water and detergent solution.

# WHEELCHAIR LIFT MAINTENANCE CHART

Operation	Service Intervals *		Months / Miles Whichever Occurs First
	Months	Miles	General Instructions
<b>BRAUN</b>			
Grease Safety Barrier Latch	1	1,000	See Braun L205 Owner's Manual. Use light oil 30 weight or equivalent.
Lube Hinges and Pins	1 or 100 cycles	1,000	See Braun L205 Owner's Manual. Use light oil 30 weight or equivalent.
Check Cylinder Chains, Hoses and Wires	12	12,000	See Braun L205 Owner's Manual.
<b>COLLINS</b>			
Lube Bridge Plate Hinge and Pivot Points	3 or 600 cycles	5,000	See Collins (Mobile Tech) Maintenance & Service Manual. Use WD-40 lubricant.
Clean and Lube Fold Cam Slot, Platform Cam Slots and Handrail V-block	3 or 600 cycles	5,000	See Collins (Mobile Tech) Maintenance & Service Manual. Use #2 lithium grease.
Check Fluid Level	3 or 600 cycles	5,000	See Collins (Mobile Tech) Maintenance & Service Manual. Use aircraft hydraulic fluid H-5606.

Service Intervals \*

\*Service Intervals to be performed on a continuing basis.  
Example: 1 / 3,000 means every month or every 3,000 miles.

# INDEX

<b>Body Component Maintenance Chart</b> .....	<b>60, 61</b>	Refueling .....	55
Air Stop Arms .....	60	Safety Cautions & Warnings .....	53
Body Mounting .....	61	Specific Gravity .....	56
Bus Body Care .....	60	Starting Procedure .....	57
Destination Signs .....	60	Vehicle Performance & Emissions .....	57
Electric Stop Arms .....	60	<b>Destination Signs</b> .....	<b>7</b>
Emergency Equipment .....	60	<b>Doors</b> .....	<b>34</b>
Emergency Exits .....	60	Air Outward Opening Door .....	34
Heaters .....	61	Continuing Maintenance Requirements .....	34
Jackknife Door .....	60	Electric Outward Opening Door .....	35
Mirrors .....	61	Jackknife Door .....	34
Outward Opening Door .....	60	Outward Opening Door .....	34
Power Jackknife Door .....	60	Security Lock .....	36
Seats .....	61	<b>Doran Warning Light Monitor</b> .....	<b>15</b>
Vandal Locks .....	60	Diagnosis .....	16
Windows .....	60	Repair Procedure .....	15
<b>Body Master Wiring Diagram</b> .....	<b>19</b>	Tools & Supplies Required .....	17
<b>Body Tie Down</b> .....	<b>33</b>	<b>Drain Holes</b> .....	<b>50</b>
<b>Body to Chassis Wiring</b> .....	<b>20</b>	<b>Electrical Systems</b> .....	<b>11</b>
Ford .....	21	Body Wiring Identification .....	13
GMCV .....	20	Normal Current Usage .....	12
International .....	22	<b>Emergency Equipment</b> .....	<b>28</b>
Freightliner .....	23	Recommended Warning Device Positioning .....	28
<b>Circuit Breakers</b> .....	<b>18</b>	<b>Emergency Exits</b> .....	<b>29</b>
<b>Coach Identification</b> .....	<b>5</b>	<b>Foreword</b> .....	<b>4</b>
Body Serial & Service Number .....	5	<b>Heaters</b> .....	<b>38</b>
Vehicle Certification .....	5	Antifreeze .....	39
<b>Compressed Natural Gas</b> .....	<b>51</b>	Care & Cleaning of Defroster Fans .....	39
Antiknock Properties .....	57	Defrosting .....	38
Code of Federal Regulations .....	52	Driver / Passenger Comfort .....	40
Cold Start .....	57	General Information .....	38
Compressed Natural Gas Filters .....	54	Heater Bleeding Instructions .....	40
Compressed Natural Gas Fuel .....	54	Heater Defroster Location .....	40
Energy Conversions .....	57	Heater Operation .....	38
Flammability .....	56	Heater Service .....	44
Fuel Composition .....	55	Heater Water Capacity Chart .....	43
Fuel System Description .....	52	Hose Repair .....	42
Fuel Toxicity & Safety .....	56	Preventive Maintenance .....	42
Introduction .....	51	Removal of Underseat Fan & Motor Assy. ....	41
Maintenance .....	58	Removal of Underseat Heater Coil .....	42
National Fire Protection Association .....	52		
Operation & Maintenance of Components .....	58		
Owner / Operators Responsibilities .....	51		

<b>Inspection</b> .....	<b>5</b>	<b>Spare Tire Location &amp; Removal</b> .....	<b>51</b>
Daily Inspection .....	5	<b>Stop Arms</b> .....	<b>31</b>
Prior to Placing New Bus in Service .....	5	Air Stop Arm Troubleshooting .....	31
Weekly Inspection .....	6	Electric Stop Arm Troubleshooting .....	32
<b>Introduction</b> .....	<b>3</b>	Stop Sign Blade Failure .....	32
<b>Keeping Your Vehicle Looking New</b> .....	<b>37</b>	<b>Switch Panel</b> .....	<b>7</b>
Finish Damage .....	37	<b>Transpec Safety Vent</b> .....	<b>30</b>
Floors & Floorcovering .....	37	Maintenance Cautions .....	30
Foreign Material Deposits .....	37	Service & Repairs .....	30
Polishing & Waxing Your Vehicle .....	37	<b>Vandal Locks</b> .....	<b>36</b>
Washing Your Vehicle .....	37	Emergency Door .....	36
<b>Light Bulb Data</b> .....	<b>14</b>	Entrance Door .....	36
Exterior Lights .....	14	Sliding Bolt .....	36
Interior Lights .....	14	<b>Visibility Equipment Required by FMVSS</b> .....	<b>24</b>
<b>Lower Side Panel Repair Procedure</b> .....	<b>49</b>	<b>Warning Light Door Switch Adjustment</b> .....	<b>50</b>
<b>Mirrors &amp; Mirror Adjustment</b> .....	<b>26</b>	<b>Wheelchair Lift Maintenance Chart</b> .....	<b>61</b>
Exterior Mirrors .....	27	Braun Lift .....	61
Interior Mirrors .....	26	Collins Lift .....	61
8" Dia. Supplemental Exterior Rearview .....	26	<b>Wheelchair Lifts</b> .....	<b>30</b>
<b>Quick Reference Maintenance Charts</b> .....	<b>60-61</b>	<b>Windows &amp; Windshields</b> .....	<b>46</b>
<b>Reporting Safety Defects</b> .....	<b>4</b>	Entrance Door Glass Replacement .....	47
<b>Seats &amp; Seat Belts</b> .....	<b>8</b>	Rear Vision Glass Replacement .....	48
Driver's Seat .....	8	Split Sash Window & Glass Replacement .....	46
Driver's Seat Belt Operation .....	8	Window Latch Replacement .....	47
Driver's Seat Belt w/Shoulder Harness .....	9	Windshield Glass Replacement .....	46
Driver's Seat Lubrication .....	8	<b>Windshield Wipers</b> .....	<b>49</b>
Passenger Seat Belt Operation .....	9	Wiper Assembly Replacement .....	49
Seat Belt Inspection & Maintenance .....	9	Wiper Refill Replacement .....	49
Seat Care & Cleaning .....	10		
Seat Cushion Service (DOT Seats) .....	10		
Seat Cushion Service (DOT Seat Belt Seats) .....	10		
Seat Inspection & Maintenance .....	9		
Track Mounted Seats .....	11		
<b>Scheduled Maintenance</b> .....	<b>58</b>		
Monthly or 1,000 Miles .....	58		
3 Months or 5,000 Miles .....	59		
3 Months or 24,000 Miles .....	59		
6 Months or 6,000 Miles .....	59		
12 Months or 12,000 Miles .....	59		

---

**Part Number: 0002753**  
**Blue Bird Corporation • P.O. Box 937 • Fort Valley, GA 31030**