



# TC/1000 & 2000 FORWARD ENGINE MODELS

## Owner's Manual



BLUE BIRD

# TABLE OF CONTENTS

---

Introduction .....	3	Windows & Windshields .....	46
Forward .....	4	Windshield Wipers .....	50
Reporting Safety Defects .....	4	Lower Side Panel Repair Procedure .....	51
Coach Identification .....	4	Spare Tire Location & Removal .....	51
Inspection .....	5	Tires, Wheels & Rims .....	52
Operator's Compartment .....	7	Jacking Instructions .....	54
Tilt & Telescoping Steering .....	7	Engine Operating Instructions .....	55
Instrument Panel & Controls .....	8	Noise Emissions Warranty .....	57
Switch Panel .....	11	Fuel & Lubricant Requirements .....	57
Destination Signs .....	11	Compressed Natural Gas .....	58
Seats & Seat Belts .....	12	Manual Five Speed Transmission .....	65
Flat Floor Units .....	15	Allison Automatic Transmission .....	65
Electrical Systems .....	16	Hydraulic Brakes .....	70
Light Bulb Data .....	17	Air Brakes .....	72
Doran Warning Light Monitor .....	18	Door/Brake Interlock .....	74
Circuit Breakers .....	21	Hydraulic System Troubleshooting .....	75
Mirrors & Mirror Adjustment .....	21	Cooling System .....	76
Emergency Equipment .....	23	Fan Clutch .....	76
Emergency Exit .....	25	TC Pitman Arm .....	77
Wheelchair Lifts .....	26	Wheelbearing Adjustments .....	78
Transpec Safety Vent .....	26	Rear Axle Vent .....	78
Stop Arms .....	27	Suspension Clearance .....	79
Winterfront Cover .....	29	Scheduled Maintenance .....	79
Front Access Panels .....	30	Maintenance Service Key .....	82
Access Doors .....	30	Quick Reference Maintenance Charts .....	83
Body Tie Down .....	31	Suspension Maintenance Chart .....	83
Towing or Pushing .....	31	Axle Maintenance Chart .....	84
Doors .....	32	Brake Maintenance Chart .....	85
Vandal Locks .....	35	Chassis Component Maintenance Chart .....	86
Keeping Your Vehicle Looking New .....	36	Body Component Maintenance Chart .....	87, 88
Engine Access .....	36	Wheelchair Lift Maintenance Chart .....	88
Heaters .....	37	General Data .....	89
Engine Block Heaters .....	45	Electric Vehicle Information .....	90
		Index .....	100



# INTRODUCTION

---

Thank you for selecting the Blue Bird TC. Your TC is the result of mass transportation developments, which have been ongoing since 1927. The design and construction of the TC reflects Blue Bird's concern for efficient, and above all, Safe Operation.

This manual has been prepared to acquaint you with various aspects of service, maintenance and operation. It explains the various features and controls which should be familiar to the operator before he/she attempts to drive the unit and will help keep your Blue Bird TC in top operating condition and help extend its service life.

Your Blue Bird TC may have all or some of the equipment described in this manual. Therefore, you may find maintenance data for equipment not installed on your bus. Text, illustrations and specifications in this manual are based on information available at the time of printing. We reserve the right to make changes at any time without notice. To obtain maintenance and parts information, refer to Blue Bird Chassis Maintenance Manual and Parts Catalog. You are encouraged to contact your Blue Bird distributor, if additional maintenance information or assistance is needed.

The complete line of Blue Bird Service Parts is available from your Blue Bird distributor. The use of original Blue Bird replacement parts and components will help insure that the design features inherent in the TC remain for the life of the vehicle.

Proper operation, service and maintenance is important to the safety and reliability of all motor vehicles. The information contained herein is provided as a reference for systems and components that require periodic service. The intervals given are manufacturer's recommendations and should be considered maximum intervals. Actual operating conditions must be considered and maintenance intervals adjusted accordingly. Anytime a system does not perform satisfactorily, corrective service should be performed at once.

Familiarity with automobile operation and controls is not a prerequisite, but is assumed to be common knowledge to all who will be operating this coach. Basically, control and operation of both are the same, but some distinct differences must be recognized before operation of the coach is attempted.

**Remember:** The bus is 8 feet wide without outside mirrors and is 25 to 40 feet long. Therefore, it is 2 feet wider and 2 to 3 times as long as the average automobile. The driver sits in front of the wide track front axle, so the steering has a completely different feel. Acceleration will very likely be slower than that of an automobile. The feel of the brakes may differ from that which is familiar to the new operator. This makes it very important, from a safety standpoint, for him or her to become completely familiar with that function through experience before attempting passenger transit. The operator will observe other differences, but after acquiring basic familiarization and some practical experience, he will find the operation quickly becomes quite natural, comfortable and far from difficult.

**CAUTION: No one should attempt to operate this coach without a thorough knowledge of all instruments and controls, without having had actual driving experience in this or a similar vehicle under supervision, and without having the appropriate license or permit to operate it. Do not drive the coach until the space in front, on the sides and in the rear is unobstructed. Most accidents occur because the operator did not ensure that there was no one in the way before driving.**

**This manual should be read before the operator attempts to drive the unit.**

This manual provides you with the most current maintenance and operation information. We welcome your comments and suggestions regarding this manual. All correspondence should be directed to the Technical Services Department of Blue Bird Body Company, P.O. Box 937, Fort Valley, GA, 31030, Attn: TECHNICAL SERVICES.

## FOREWORD

---

This Operator's Manual provides some general, as well as specific, information regarding safe operation and maintenance of your Blue Bird bus. It does not address all items or situations that may arise and is not a substitute for proper driver and mechanic training. The exercise of care, common sense and good driving and working practices are required for safe operation.

If specific questions or concerns arise that are not adequately addressed in this manual, please contact your Blue Bird distributor. The distributor will answer your questions or put you in contact with the proper factory personnel.

Throughout this guide you will find **CAUTIONS** and **WARNINGS**. **CAUTIONS** are given to prevent you from making an error which could damage the vehicle and possibly cause personal injury. **WARNINGS** remind you to be especially careful to avoid personal injury.

Blue Bird Corporation offers many items as standard and optional equipment to meet state, federal and local specifications and individual customer requirements. Properly selected equipment can help insure reliable and safe transportation of passengers.

Some examples of this safety equipment are: stop arms, crossing guards, warning lights, warning light monitors, mirrors, first aid kits, fire extinguishers, warning reflectors, fuses, directional and brake lights, warning buzzers, vandal locks, emergency exits and seat belts.

It is the driver's responsibility to insure that the safety items are in proper order. Equipment relating to safety should be checked for operation on a daily basis. Safety equipment may vary due to state and federal specifications, and individual customer requirements.

In addition, the driver/operator must insure that the loading area around the bus is clear of pedestrians before stopping and that all unloaded passengers are a safe distance away from the bus before moving.

## REPORTING SAFETY DEFECTS

---

If you believe your vehicle has a safety defect which could cause a crash or could cause injury or death, you should immediately inform the National Highway Traffic Safety Administration (NHTSA) in addition to notifying Blue Bird Corporation.

If NHTSA receives similar complaints, it may open an investigation and, if it finds that a safety defect exists in a group of vehicles, it may order a recall and remedy campaign. However, NHTSA cannot become involved in individual problems between you, your dealer or Blue Bird Corporation.

To contact NHTSA you may either call the Auto Safety Hotline toll free at 1-800-424-9393 (or 366-0123 in Washington, D.C. area), or write to: NHTSA, U.S. Department of Transportation, Washington, D.C. 20590. You can also obtain other information about Motor Vehicle Safety from the hotline.

## COACH IDENTIFICATION

---

The **Vehicle Certification Plate** certifies that the vehicle conforms to all applicable Federal Motor Vehicle Safety Standards in effect at the date of manufacture. Do not remove or deface this plate.

MANUFACTURED BY	
<b>BLUE BIRD BODY COMPANY</b>	
DATE OF MFR. _____	
INC. VEH. MFG. BY _____	DATE _____
SUITABLE TIRE - RIM CHOICE	
GVWR _____	
GAWR : FRONT _____	WITH _____ TIRES
_____	RIMS, AT _____ PSI COLD SINGLE
GAWR : REAR _____	WITH _____ TIRES
_____	RIMS, AT _____ PSI COLD DUAL
THIS VEHICLE CONFORMS TO ALL APPLICABLE FEDERAL	
MOTOR VEHICLE SAFETY STANDARDS IN EFFECT IN _____	
V.I.N. _____	CLASSIFICATION _____

The **Body Serial** and **Service Number Plate** is located on the front upper inner panel above the windshield. Refer to the data on this plate for registration purposes or for replacement part information.

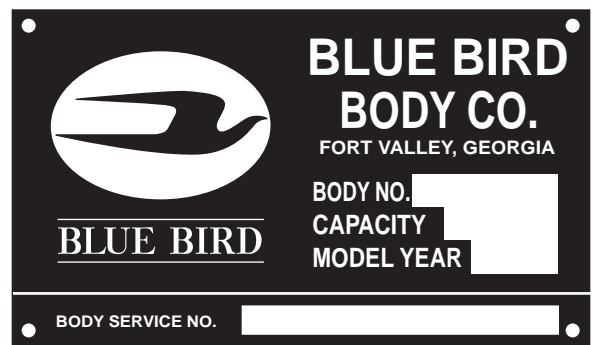

The **Axle Record** and **Chassis Service Number Plate** is located on the front upper inner panel above the windshield. Refer to the data on these plates for registration purposes or for replacement part information.

FURNISH INFORMATION BELOW WHEN ORDERING AXLE PARTS	
CHASSIS SERIAL	ENGINE SERIAL
FRONT AXLE	BRAKE LINING FMSI NO. & FRICTION CODE
BRAKE DRUM	
REAR AXLE	BRAKE LINING FMSI NO. & FRICTION CODE
BRAKE DRUM	
REAR AXLE RATIO	
CHASSIS SERVICE NO.	

## INSPECTION

### PRIOR TO PLACING THE NEW BUS IN SERVICE, PERFORM THE FOLLOWING:

- Check suspension u-bolt torque.
- Check Neway suspension torque.
- Check brake adjustment.
- Check body tie-down bolts torque.

### DAILY INSPECTION

In order to keep your bus in the best operating condition from the standpoint of safety, convenience, service and operating expense, it is recommended the following inspection procedures be followed on a daily basis. Any malfunctions or defects should be corrected before the next trip. Report needed services to responsible maintenance personnel.

- Check fuel level.
- Drain air tanks (cold weather).
- Check engine oil level.
- Check coolant level.
- Check automatic transmission fluid level.

#### **Look outside the bus:**

- Windshield, mirrors, front windows, head, tail, directional, and stop lights - wipe clean.
- Exhaust - tailpipe clear?
- Rear emergency door, open and close, check warning buzzer operation.
- Tire pressure and tread, OK? Lug nuts in place?
- Drain air brake tank.
- Look under bus - all clear?
- General outside appearance, clean for school bus identification?
- Mirrors - clean and adjusted?

**Look inside the bus:**

- Seat, floor - housekeeping. Steps and aisle clear?
- Emergency exits open & close, rear door, windows.
- Emergency equipment.
- Fire extinguisher pressure.
- First aid kit.
- Driver's area - windshield, windows clean?
- Mirrors - clean and adjusted?
- Emergency doors/windows unlocked and operate freely?
- Do buzzers activate when exits are not fully latched?

**Starting the engine:**

- Be sure parking brakes are on.
- Put in Neutral.
- With key on, check: Fuel gauge OK? Check brake warning buzzer or light, neutral safety switch.
- Start engine - look, listen for trouble signs, check gauges.

**With the engine running, check (from driver's seat):**

- Mirrors, interior and stepwell lights, service door seal.
- Steering feel OK? Noise?
- Horn, defroster & heater blower, windshield wiper operation.
- Brakes - pedal height & feel, gauge reading OK? Parking brake release, reset.

**Outside checks required before you drive away:**

- Turn signals - right & left, front & rear - clean & flashing?
- Flasher warning lights - front & rear - clean & flashing?
- Stop arm (if used) - clean & working?
- Headlights hi-lo beams.
- Stoplights & taillights - clean & working?
- Hazard flasher working?

**Final check as you move the bus:**

- Seat belt fastened?
- Brakes - Stop & hold?
- Steering feel OK? Unusual noises? Bus under control- tracking straight?
- Brake to a stop. All gauges OK?

**Remember:** Safety on the road also depends on you. Observe weather and road condition and drive accordingly. Be physically and mentally alert. When backing in vicinity of congestion or pedestrians use outside monitor or director. Look around before driving away from where you are parked and observe all traffic rules and regulations.

**WEEKLY INSPECTION**

- Adjust shoe-type brakes.
- Drain air tanks (warm weather).
- Check tires.
- Inspect seat cushion attachments for tightness.
- Inspect seat belts and buckles.
- Inspect outside lights for proper operation.

# OPERATOR'S COMPARTMENT

1. Driver's seat.
2. Switch panel.
3. Horn button - sounds electric horn.
4. Instrument panel.
5. Turn signal lever - operates turn signals.
6. Automatic transmission shift control (range selector or electronic push button pad) location.
7. Heater and defroster controls.
8. Brake pedal or air treadle - applies service brakes.
9. Accelerator pedal - controls engine speed.
10. Dimmer switch - selects headlight high or low beam.
11. Tilt steering lever.
12. Headlight switch.
13. Ignition switch - controls ignition and starting circuits.
14. Parking brake - prevents unit from rolling when parked.
15. Throttle lock - for high idle or warm-up.

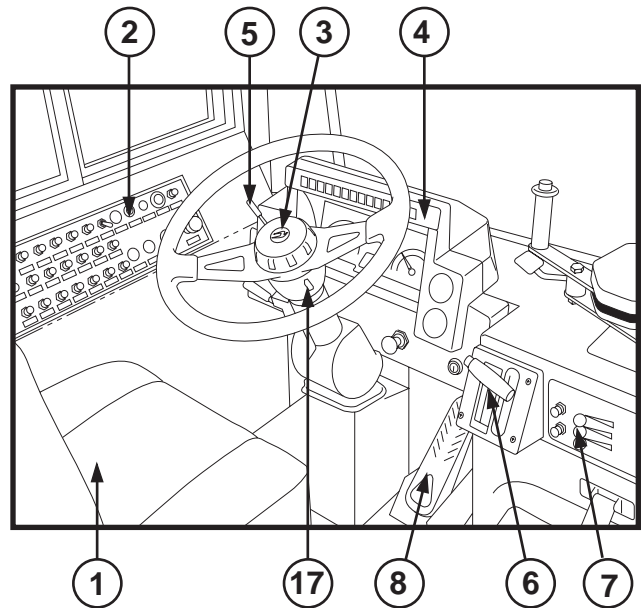

**WARNING: Do not use throttle lock as a means of cruise control. Always release throttle lock before putting vehicle into motion.**

16. Driver's fresh air vent control.
17. Hazard light flasher switch.

## NOT ILLUSTRATED

- Door control.
- Wig-Wag - low air pressure warning.
- Warning light monitor - indicates whether warning light are working.
- Inside mirror.
- Fusee canister.
- Reflector flares and flags
- High idle switch.

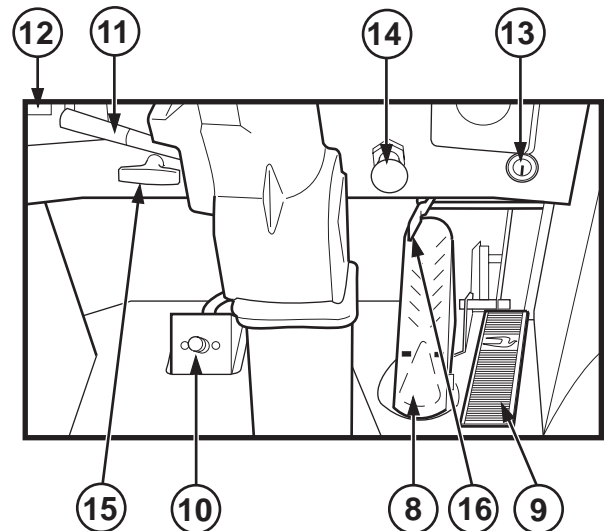

# TILT & TELESCOPING STEERING

To adjust steering wheel position, use the tilting lever located on the left side of steering mounting bracket. Press lever downward to unlock steering column. Move column to one of four positions and release lever. To raise or lower the steering wheel position, pull up on the tilting lever. This will enable you to raise or lower the steering wheel to one of its seven positions.

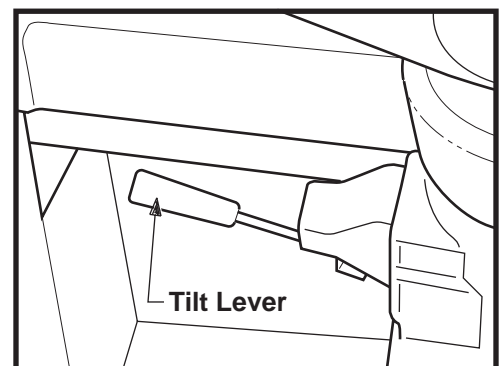



# INSTRUMENT PANEL & CONTROLS

## DASH AND INSTRUMENT PANEL

1. Ammeter (Optional) - indicates battery charge and discharge.
2. Headlight/Parking light switch - On/Off.
3. Dash light rheostat switch - Dims and/or brightens dash lights.
4. Combustion air restriction gauge (Optional) or Sanders switch (Optional) - Combustion air restriction gauge measures air restriction through air intake and indicates service required for air filter. Sanders switch operates sanders function.
5. Cruise control on/off switch (Cummins ISB & ISC engines) - Activates or inactivates the cruise standby mode.
6. Cruise set/resume switch (Cummins ISB & ISC engines) - When vehicle reaches desired cruise speed depressing the set switch sets the speed. When the vehicle drops below 30 MPH or brake pedal is depressed the cruise returns to standby mode. To reactivate to preset speed depress the resume switch.
7. Transmission oil temperature gauge (Optional) - Indicates transmission oil temperature in transmission sump.
8. Multifunction Gauge Switch - Toggle/Scroll switch for multifunction gauge. (See CLUSTER INSTRUMENTATION)
9. Ignition switch - controls ignition and starting circuits.
10. Parking brake valve - prevents unit from rolling when parked.
11. High idle switch - Sets engine at high idle RPM.
12. Low idle adjustment (Cummins ISB & ISC engines) - Low engine idle speed can be adjusted between 700 & 875 RPM. This permits the operator to adjust the idle speed up or down in increments of 25 RPM. When adjusted, a new low engine idle speed is established and saved when the key switch is turned off.
13. Quick start aid (Optional) - Aids in quick start of engine by injecting a measured amount of Ether.
14. Engine Maintenance Lamp (On Cummins ISB & ISC engines) - Amber lamp indicates engine maintenance is needed.

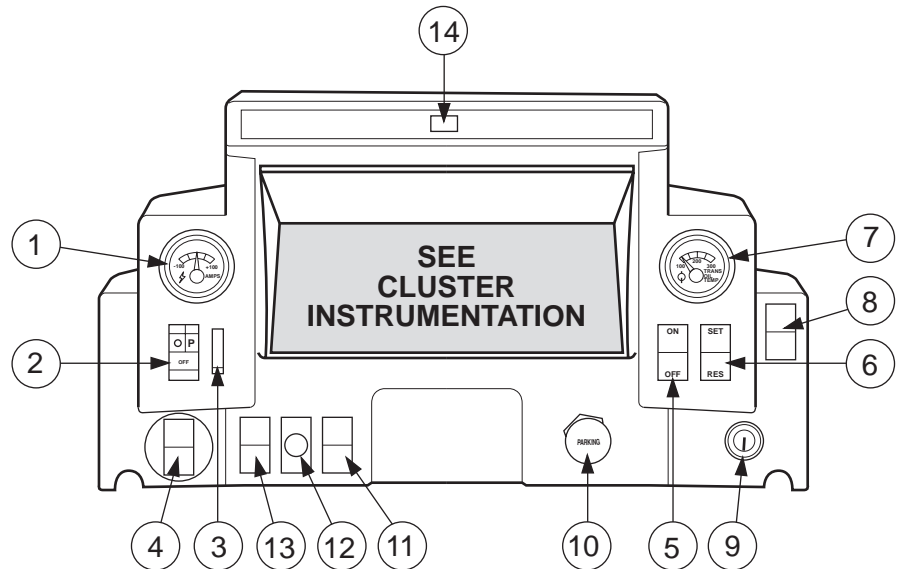

## CLUSTER INSTRUMENTATION

This unit has been delivered with the new Blue Bird instrument cluster. Reducing instrumentation by combining gauges and providing easily recognized and viewed indicators, the cluster is a system designed with several new features that emphasize enhanced vehicle safety and driver ergonomics.

The cluster is programmed at the factory for the specific application. Information specific to the engine, transmission, axle, and tires is entered. The multifunction gauge, indicator lights, and chassis alarm buzzers are indications provided should vital parameters exceed allowable limits. Changing of any component could require that the dash be reprogrammed. The instrumentation under normal conditions shows speed, engine RPM, fuel level and odometer. See the following for description of components.

1. Speedometer/Kilometer gauge is a precision electronic instrument that is programmed for specific applications of engine, transmission, tire size and drive axle ratio. The cluster and the speedometer are easily programmable by your Blue Bird distributor to maintain factory precision should you change tire sizes. To maintain speedometer accuracy, tires must be maintained at proper inflation. This gauge indicates vehicle speed MPH and kilometers per hour.
2. Multifunction gauge - (See MULTIFUNCTION GAUGE).
3. Tachometer - The tachometer is a precision electronic instrument that is programmed for specific applications, it indicates engine RPM x 1000.
4. Indicator light panel - Panel equipped with lights to indicate conditions of individual operating systems. (See INDICATOR LIGHT PANEL)
5. See (LIQUID CRYSTAL DISPLAY).

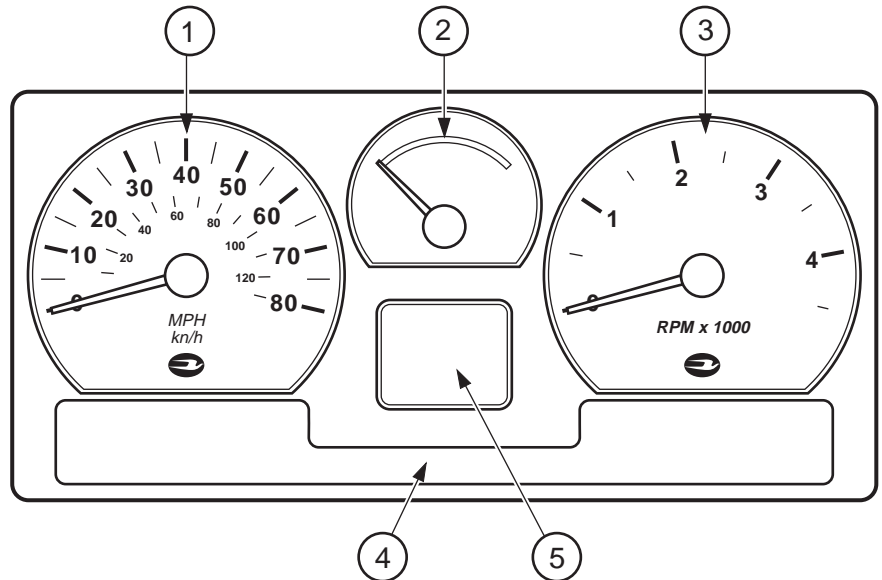

### MULTIFUNCTION GAUGE

One prominent new feature is the multifunction gauge combining several engine functions into one focal point. This feature allows the driver to concentrate more on driving conditions and safe passenger transportation without being distracted by multiple gauges.

The multifunction gauge in center of the instrumentation panel indicates 1) fuel level, 2) oil pressure, 3) battery voltage and 4) coolant temperature. The conditions are shown in the following illustration. Under standard operating condition the multifunction gauge at start up will indicate in sequence all conditions and then return to the default condition which is fuel level indication. Should one of the other three designated operating parameters reach alarm conditions particular to the engine application, the gauge will switch to display that parameter, and the corresponding indicator light will illuminate. An audible alarm also will sound should oil pressure and/or coolant temperature exceed alarm limits. The operator can scroll via the toggle switch to check other conditions of the multifunction gauge. Toggle switch is identified in DASH AND INSTRUMENT PANEL section. A warning chirp sounds whenever the gauge switches to another parameter whether it is a warning condition or driver initiated by toggle. In the event that the gauge is sequenced away from the fuel gauge and left alone for more than 30 seconds, it will return to fuel automatically. If a warning condition exist the multifunction gauge will chirp and show the condition requiring attention; warning condition will continue until condition is serviced. Under multiple warning conditions the gauge will chirp and scroll between the conditions requiring service. The operator is not distracted from the primary task of safe passenger transportation by monitoring gauge movements or interpreting gauge readings. The operator concentrates on safe bus operation and allows the cluster to monitor specific vehicle parameters.

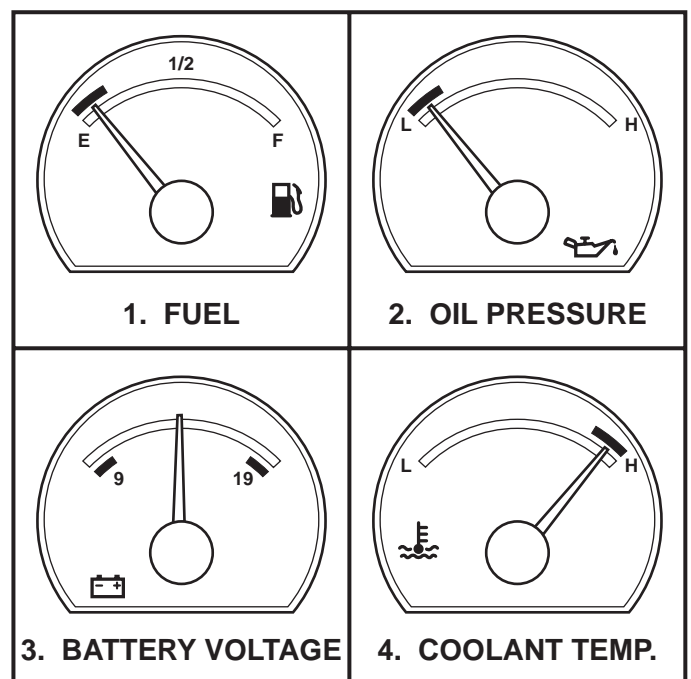

**WARNING: An engine buzzer will sound to indicate low oil pressure and/or high coolant temperature. Do not operate vehicle under these conditions. NOTE: Battery voltage alarm will beep if battery voltage is below 11.5 volts or above 14.5 volts. The battery voltage gauge will remain "ON" until condition is corrected.**

### LIQUID CRYSTAL DISPLAY

The liquid crystal display (LCD) air gauge, if so equipped, graphically represents air pressure in the front and rear air brake systems. It displays relative pressure values in green and red color segments with one set of segments for front brakes and one set for rear brakes. With minimal distractions, the vehicle operator can see good air pressure indicated by the green segments. Dangerous air pressure conditions are indicated by red segments as well as the LOW AIR indicator light, the brake warning indicator, and an audible alarm. The air compressor is set to maintain normal system pressure at 120 +/- 5 psi, which also is the point where the LCD changes from the fourth to the fifth green segment. Due to variance in air systems and in relative pressure measurements, the LCD air gauge may routinely display normal system pressure with four green segments in one brake system and the fifth green segment in the other brake system. Normal pressure is indicated with four or five green segments in each brake system.

As an additional enhancement feature to the instrumentation the LCD is equipped with an engine hourmeter. The engine odometer/hourmeter can also be toggled by the operator without engine ignition. By turning the headlight switch to the "ON" position the operator can scroll between odometer setting and hourmeter setting via the multifunction gauge toggle switch on dash. The odometer (1) records mileage on vehicle while the hourmeter records lapse time of engine running.

1. Engine Odometer/Hourmeter.
2. Indicates air pressure in rear reservoir.
3. Indicates air pressure in front reservoir.

On air brake units this instrument is also equipped with an air pressure liquid crystal bar graph gauge that indicates air pressure in 15 degree increments between 0 and 150 PSI. Pressure below 60 PSI are indicated in red. Pressure above 60 PSI are indicated in green. **NOTE:** Air pressure LCD will not display below -20 degrees C or -4 degrees F.

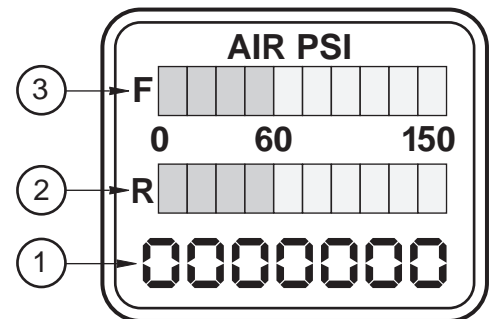

**WARNING: Do not drive the vehicle until system air pressure has built up.**

### INDICATOR LIGHT PANEL

Another safety enhancement to the cluster is the programmable low fuel indicator. It can be programmed by your Blue Bird distributor to monitor fuel level and provide warning when level reaches programmed setting. The default setting is 1/8 of a tank.

Indicator lights are provided to depict all functions of the multifunction gauge, warning conditions and system operations. The indicators are easily recognized and described below.

1. Engine Retard (Optional) - Red light indicates that the engine retarder is engaged.
2. Brake Warning - Red light with buzzer indicates that brake pressure is low.

**\*\*WARNING: In the case of a brake system failure, a warning buzzer will sound and warning light illuminate, giving an indication that trouble is evident. The coach must not be operated under those conditions, but repaired before continuing operation.**

3. Stop Light - Red light indicates that service brake is applied.
4. Anti-Lock (Optional) - Amber light indicates an anti-lock brake fault.
5. High Beams - Blue light indicates that headlights are in High Beam.
6. Low Coolant - Red light indicates that coolant is low.

7. Coolant Temperature - Red light indicates that coolant temperature is out of limits.
8. Oil pressure - Red light indicates that oil pressure is low.
9. Left Turn Directional - Green light indicates left turn.
10. Fuel - Amber light indicates low fuel at approximately 1/8 of a tank.
11. Low Air - Red light with buzzer indicates that air brake pressure is low.\*\*
12. Parking brake - Red light indicates that parking brake is engaged.
13. Fuel Filter (Optional) - Red light indicates that fuel filter needs checking.
14. Sander Refill (Optional) - Red light indicates that sand quantity is low.
15. Engine Preheat (Optional) - Green light indicates diesel engine preheat Wait until light goes out to start.
16. Service Engine Soon (Optional) - Amber light indicates that engine requires service soon.
17. Stop Engine (Optional) - Red light indicates that engine must be stopped immediately.
18. Engine Over-Speed (Optional) - Amber light indicates that engine is running over speed.
19. Right Turn Directional - Green light indicates right turn.

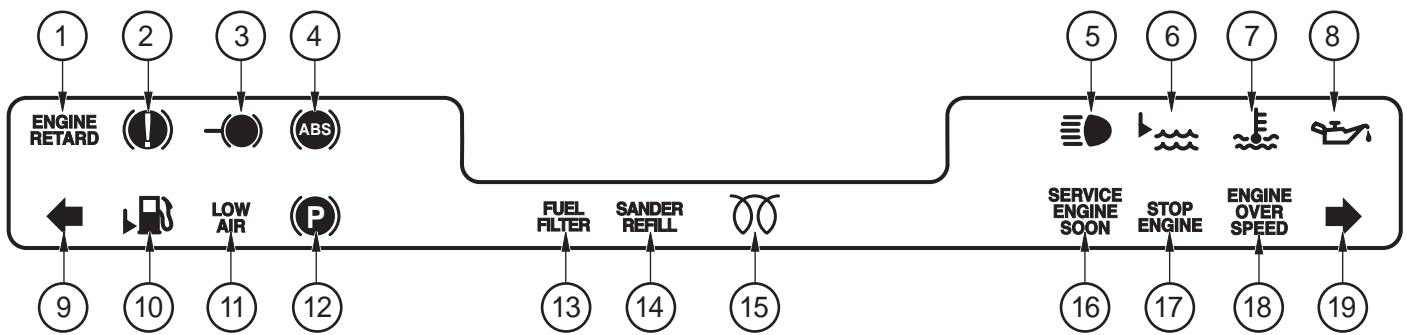

## SWITCH PANEL

1. Dome
2. Cluster Lamps
3. Pilot
4. Manuals
5. Master
6. Fan
7. Wipers/Washers

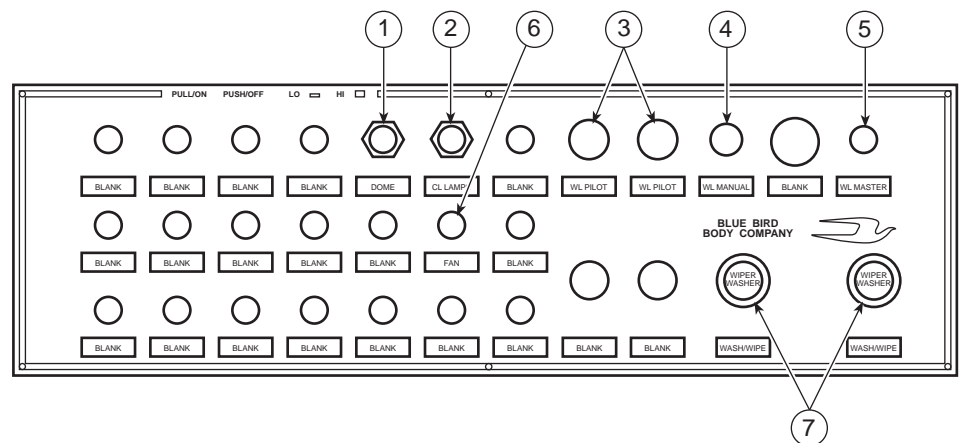

## DESTINATION SIGNS

**Hinged Sign Front** - Mounted on outside of front roof cap with internal control for changing sign. Periodically lubricate hinges and lever assembly with lightweight lubricating oil.

**Hinged Sign Rear** - Mounted on outside of rear roof cap, manually changed from outside. Periodically lubricate hinges with lightweight lubricating oil.

**One Station Lighted Curtain** - Replace bulbs as needed. Curtain may occasionally loosen and cause slack in the curtain due to vibration. To tighten curtain, loosen bolts, pull curtain tight, retighten bolts.

**Roller Destination Sign with Lighted Curtain** - Replace bulbs as needed. Curtain may occasionally require same adjustment as One Station Sign. Periodically lubricate roller gears with light grease, such as "White Lube," and hinges on access door with lightweight lubricating oil. To change sign, turn crank located on front upper inner panel above windshield to desired destination.

**Two Station Sign** - Front lighted, sign material masonite with lettering on both sides. Lubricate interior door hinge on front upper inner panel with lightweight lubricating oil.

**Lighted "School Bus" Sign** - Back lighted yellow plexiglass sign. Replace bulbs as needed. Lubricate interior door hinge on front upper inner panel with lightweight lubricating oil.

**NOTE:** All maintenance procedures to be done at 6 months or 6,000 mile intervals, whichever occurs first.

## SEATS & SEAT BELTS

### DRIVERS SEAT

The driver's seat may be adjusted fore and aft by pushing forward the release lever located beneath the seat at the center right side, adjusting the seat, and releasing the lever when the seat is in the desired position. To raise or lower the seat, release two height adjustment handles by turning counterclockwise. Raise the seat by lifting it to the desired position. Lower the seat by depressing the height adjustment pedal to release the latch mechanism. Retighten the adjustment handles after the seat is in the desired position. (See illustration)

**WARNING: Do not attempt to adjust seat while vehicle is in motion. Do not adjust height adjustment while sitting in driver's seat. Keep feet and other items away from height adjustment handles and pedals while vehicle is in motion.**

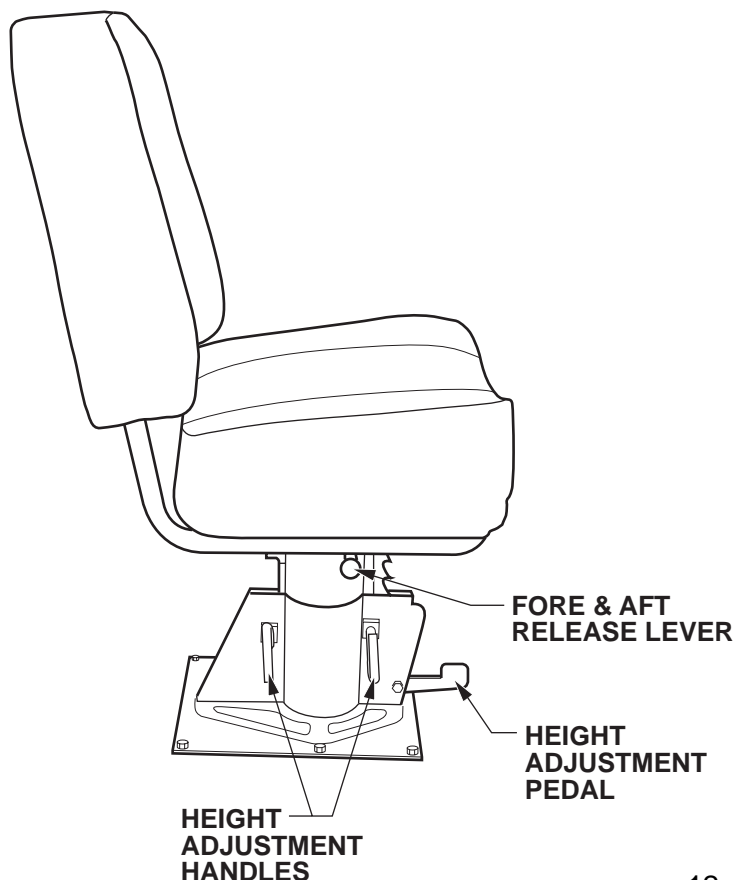

### DRIVER'S SEAT LUBRICATION

Moving parts of the driver's seat require lubrication for ease of operation, as well as, longevity of the seat and prevention of excessive wear.

Currently available white lithium-based grease in an aerosol can, gives excellent coverage, when carefully directed into moving part joints. The very light coating of lubrication provided by aerosol-carried solvent-type solution works very well for penetrating into a joint and cleaning away dirt, but should only be depended on for lubrication, if frequently applied. A common 10W30 or 10W40 motor oil will provide good lubrication.

Remember that all moving part joints, tilt pivots, slide forward/back adjustment and vertical motion pivots (4 total) require lubrication. This should be done every six months or 6,000 miles, whichever occurs first, with a lithium-based grease in aerosol form.

## DRIVER'S SEAT BELT OPERATION

Driver's seat belt should be worn at all times when the vehicle is being driven.

Blue Bird driver's seat belts have automatic locking retractors and are self-adjusting. They also have an anti-cinch device which prevents the belt from uncomfortable tightening as you drive. To use, withdraw ample length of belt from retractor or retractors to allow engagement of buckle halves. Engage buckle halves and allow retractor to withdraw belt to a snug fit. Attempt to pull belt from retractor after it has been withdrawn to assure the automatic locking mechanism is operating properly.

The buckle can be released by pushing button in center of buckle.

## DRIVER'S SEAT BELT WITH SHOULDER HARNESS (IF SO EQUIPPED)

Driver's seat belt should be worn at all times when the vehicle is being driven.

Driver's seat belt shoulder harness is emergency locking; lap belt may be either emergency locking or automatic locking depending on the option chosen. The emergency locking retractor used for all shoulder harnesses and specified lap belts is dual sensitive. Emergency locking retractor engages when the vehicle tips 15 degrees or more or if belt speed exceeds a preset rate. Automatic locking retractors for specified lap belts are self adjusting. If your unit is equipped with the optional adjustable D-ring shoulder harness bracket, adjust D-ring for maximum comfort.

To use, withdraw ample length of belt from retractor or retractors to allow engagement of buckle halves. Engage buckle halves and allow retractor to draw belt to a snug fit.

The buckle is released by pushing the button in center of buckle.

## PASSENGER SEAT BELT OPERATION IF SO EQUIPPED

Individual lap belts for passengers are retractable or non-retractable depending on option ordered. Insert the catch into the buckle, test for assurance of latch fit and pull loose end of strap until belt fits snugly across the lower hips. The buckle can be released, by pushing button in center of buckle. The adjustable end can be moved outward on its strap by turning 90 degrees to the strap and pulling.

## SEAT BELT INSPECTION & MAINTENANCE

Inspect seat belts and their attachments on a weekly basis. Check seat belt buckles and adjustability to insure proper operation. If necessary, lubricate buckle with a graphite lubricant. When buckle is found to be inoperable, replace immediately. If there are any defects in the webbing (i.e. torn or frayed), the complete seat belt must be replaced as soon as possible to ensure passenger safety. Hand wash webbing with warm water and mild soap. Rinse thoroughly and dry in the shade. Do not bleach or redye, because such processing may severely weaken the assembly.

**WARNING: Be sure the lap belt is fitted snugly around the hips, not the waist. Failure to do so may increase the chance of injury in the event of a collision. Do not bleach or redye, because such processing may severely weaken the assembly.**

## SEAT INSPECTION & MAINTENANCE

Blue Bird seats are built to meet Federal Motor Vehicle Safety Standards. In order to provide even safer passenger transportation, the following guidelines should be met.

1. Inspect and retighten seat leg and wall side mounting bolts every 90 days.
2. Inspect and retighten cushion attachments with a Phillips head screwdriver on a weekly basis.
3. Inspect upholstery for cuts and tears every 90 days. If torn, remove upholstery by removing the staples at the bottom front of seat back or bottom of cushion and remove cover. For installation of new cover, reverse this procedure.
4. School bus seats are equipped with a special foam back pad. Should this pad ever become damaged, it should be replaced with an approved replacement part. Aftermarket suppliers do exist and should be checked for compliance with federal standards.

## SEAT CARE AND CLEANING

It is imperative that the interior of the bus be kept clean and seats are an important part of this maintenance. Regular cleaning and care will prolong the life of the seats and improve the general appearance.

**Everyday dirt and soil** - Most everyday soil and dirt may be removed with a soap and water solution. If the stain is persistent, a stiff bristle brush may be used. Fabric covered seats should be rinsed with clean water after stain is removed.

**Paint, tar and asphalt** - Remove stain immediately using a damp cloth and kerosene. Rub the stain gently, using small strokes. Rinse thoroughly. **NOTE:** This type of stain may become permanent if not cleaned immediately.

**Nail polish and lacquer-based stains** - Soak up as much as possible with dry cloth immediately. Any remaining stain may be removed with a nonflammable cleaning fluid such as "Tuff Stuff" or "Armorall" cleanser. Rinse thoroughly with clean water.

**Gum, grease and shoe polish** - Remove as much as possible immediately. Shoe polish if left for any length of time will permanently stain. Clean any remaining stain with "Tuff Stuff" or "Armorall" cleanser.

**Ink** - Remove stain immediately using a damp cloth and alcohol.

## SEAT CUSHION REMOVAL & INSTALLATION - DOT SEATS

**WARNING: If seat cushions are removed for maintenance, they must be reinstalled using the following instructions. Failure to comply with these instructions could result in injury from unattached seat cushions in the event of an accident.**

### REMOVAL

1. Loosen the two front swivel type clamps at the front underside of the cushion with a phillips-tip screwdriver. **Caution: Do not remove clamps.**
2. Rotate the swivel clamps so as to clear the front retaining channel frame.
3. Lift the forward edge of cushion 2 to 3 inches and pull cushion forward to remove.

### INSTALLATION

1. Place the rear edge of cushion down on the base portion of the seat frame. Lifting the forward edge 2 to 3 inches, slide the cushion to the rear to engage the positive type clamp into the rear retaining channel.
2. Lower the forward edge to the frame, making sure the swivel clamps are inside the frame and the positive type clamps are secure on the rear retaining channel.
3. Rotate the swivel clamp to engage the forward retaining channel frame.
4. Tighten with phillips-tip screwdriver until clamps do not rotate.

## SEAT CUSHION REMOVAL & INSTALLATION - DOT SEAT BELT SEATS

### REMOVAL

1. Loosen the two front swivel-type clamps at the front underside of the cushion with a phillips-tip screwdriver. **Caution: Do not remove clamps.**
2. Rotate the swivel clamp located at the rear underside of seat cushion.
3. While lifting the rear edge of the cushion, pull the cushion to the rear and remove.

### INSTALLATION

1. Place the forward edge of the cushion 2 inches to the rear of the front retaining channel. Slide the cushion forward, engaging the positive clamps onto the forward retaining channel.
2. Lower the rear edge to the frame and rotate the swivel clamps so they engage the square tube crossmember.
3. Tighten screws in front and rear clamps with phillips-tip screwdriver until clamps do not rotate.

## TRACK MOUNTED PASSENGER SEATS

If your bus is equipped track mounted passenger seats and you relocate the seats or remove the seats to accommodate wheelchairs, you must follow rules of spacing and placement to comply with FMVSS 222 "School Bus Passenger Seating and Crash Protection" and FMVSS 217 "Bus Window Retention and Release".

The decal (as shown) which gives these rules is installed on the interior body panel above the windshield.

All passenger seats must have a seat or barrier in front of it to provide compartmentalization required by Federal Motor Vehicle Safety Standards. As you reconfigure your bus, you may need additional barriers. Barriers are available from Blue Bird Body Company Part Sales.

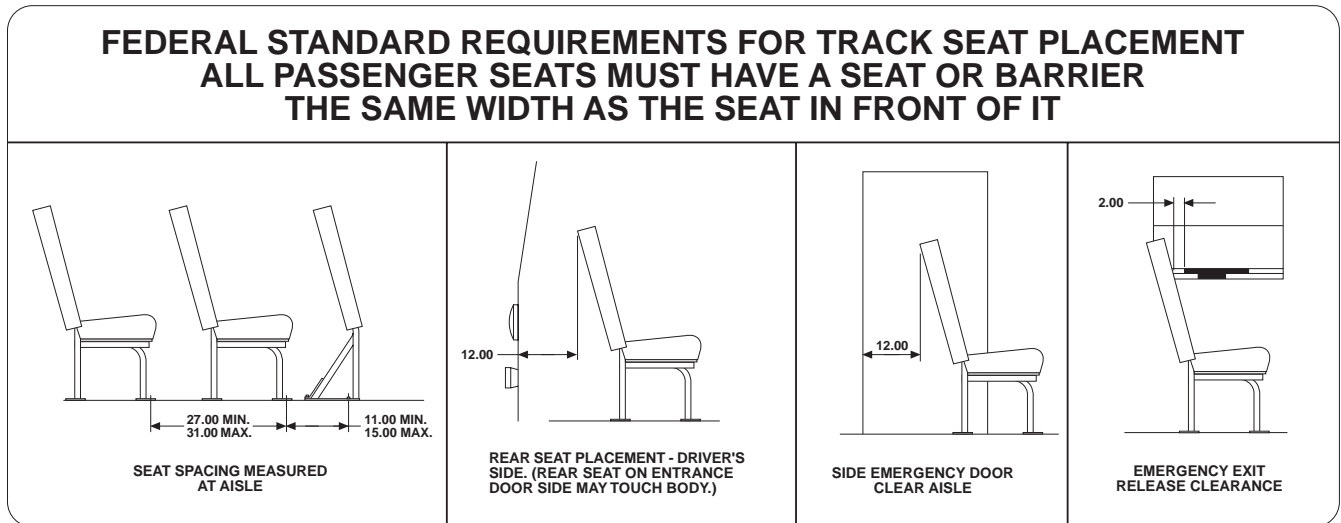

## FLAT FLOOR UNITS

**NOTE:** This information is provided for units equipped with the flat floor option. Flat floor option 3515 is offered on TCFE model 2511 as a regular option and on other models as a temporary option. The following guidelines must be followed to meet Federal Motor Vehicle Safety Standards and for ultimate passenger safety.

### SEAT AND RESTRAINING BARRIER INSTALLATION

**WARNING: This vehicle was manufactured in conformance with all Federal Motor Vehicle Safety Standards in effect on the date of manufacture. Two of the important Federal Motor Vehicle Safety Standards applicable to large school buses are FMVSS 217, Emergency Exits and FMVSS 222, School Bus Passenger Seating and Crash Protection. Anyone who adds, removes or rearranges seats and restraining barriers in this vehicle should be familiar with the requirements of FMVSS 217 and FMVSS 222 and exercise care to assure that the vehicles seat and seating arrangement remains in conformance with FMVSS 217 and 222 requirements.**

The following list of items are some of the common requirements that must be followed to assure compliance to FMVSS 217 and FMVSS 222.

- All seats and restraining barriers must be original OEM designed, manufactured and certified for school bus use with track mounted seating system.
- School bus seats must be forward facing.
- School bus seats must have another school bus seat or a restraining barrier of the same width in front of them with the proper seat spacing.



- Seat-to-seat spacing must be 27" minimum to 31" maximum, as measured from common points on the seats. **NOTE:** State or local regulations may be more restrictive.
- Seat-to-restraining barrier spacing must be 11" minimum to 15" maximum measured from the barriers front mounting hole on the aisle side leg to the front mounting hole on the seat's front aisle side leg.
- All seat mounting bolts, washers and track hardware must be of the same grade, size, and type as those originally installed in the vehicle. All 1/4" seat-to-seat mounting bracket fasteners must be torqued to 11-12 ft. lbs. All 3/8" track to seat mounting bracket fasteners must be torqued to 45-50 ft. lbs.
- Seats with seat belts must be attached to the track system in the vehicle using a total of five fasteners; three in the wall side mounting bracket and two in the aisle side mounting bracket. Special OEM track to seat mounting brackets must be used with seat belt seats to insure proper fastener spacing attaching the seat to the track system.
- Location of seats and restraining barriers installed in vehicles with lift doors is critical. Minimum clearance dimension from centerline of front bow of lift to restraining barrier varies with lift size. Contact Blue Bird Engineering for appropriate seat and barrier location.
- Seats and restraining barriers must be located such that they do not obstruct or interfere with any emergency exit label, instruction, actuation device or zone of access.
- Other FMVSS 217 and 222 requirements.

## **ELECTRICAL SYSTEMS**

---

The following guidelines must be followed when doing any work on vehicle electrical components or wiring.

1. Before beginning any electrical work, disconnect all batteries. Always remove all battery ground straps first and replace last to prevent accidental arcing.
2. Use only proper gauge wiring with high temperature insulation, such as, chemically cross-linked polyethylene, which meets SAE J-1128 (150 Degree Celsius).
3. Be certain any added circuit is protected by the use of a fuse or circuit breaker.
4. Any push-on terminal must be insulated.
5. When installing or replacing any wiring (other than ground straps), observe the following:
  - A. Always use clamps to secure wires away from any sharp metal edges or moving components.
  - B. Support wires at least every 30 inches with insulated clamps.
  - C. Where wiring is connected to moving component such as the engine, provide an adequate slack loop to allow for motion in all directions. Clamp at both sides of loop.
  - D. Be certain there is sufficient length in wires so no wires are pulled in tension.
  - E. Wires should be secured to remain four inches from exhaust pipes, manifolds or turbochargers unless components are shielded.
  - F. Use rubber grommets whenever wires must pass through holes.
  - G. Cover all full time hot or accessory and ignition hot wires with approved loom.
  - H. Avoid routing wires in contact with fuel lines or plastic components.
6. Always be sure ground straps are replaced when any work is done on engine components. The alternator must have at least a six (6) gauge strap. The engine must have one strap, engine block and transmission. (Use bolt that mounts transmission to rear face of engine block.) Allow slack loop for engine motion. Use external star tooth washer between cable and frame.
7. Do not "splice" into existing wires, instead route wire full length to appropriate source.
8. If accessories must be added, relays may be required; check installation instructions thoroughly. Use bank of circuit breakers in the electrical panel unless the accessory must be on during cranking, in which case the "hot bar" should be used.
9. Always use insulated rubber boots over hot six (6) gauge wiring on alternator, ammeter shunt or junction blocks.

**Quick Reference**  
**Wiring Circuit Color Code Major Circuits**

FUNCTION	COLOR
Left Rear Directional Light	Yellow
Right Rear Directional Light	Dark Green
Stoplights	Red
Back-up Lights	Blue
Taillights	Brown
Ground	White
Ignition Feed, Primary Feed	Black

Refer to the master wiring diagram for wire colors for other circuits.

## LIGHT BULB DATA

---

Lamp Description	Trade Name	Trade No.	Color	Bulb No.
<b><u>INTERIOR LIGHTS</u></b>				
Dome	Weldon	8005	(Standard)	89
	Weldon	8010	(Deluxe)	93
Stepwell	Arrow	35		67
Emerg. Door Light	Weldon	8025		67
Switch Panel Pilots	Cole Hersee	PL19		53
	Dial	41204-1211		68
Switch Panel Illum.		1314962		53
<b><u>EXTERIOR LIGHTS</u></b>				
Directional	KD	772-9105		1156
	Weldon	1010 Series	Red & Amber	
			Plain & w/ Arrow	1156
Warning Light	Signal Stat	1604		1156
	Guide	3111-04	Amber	1156
	Arrow	B-776-A12		4433A
Cluster & Marker		B-776-RR		4433R
	Weldon	1020-Series	Red & Amber	4636
	Weldon	5050	Amber & Red	409
Side Directional	Peterson	122	Amber & Red	194
	Peterson	122		194
	Arrow	059-9900021CP		1073
Stop-Tail/Tag	Dominion	70-6128-71		1157
	Signal Stat	2103		1157
Back-UP	KD	854-5301		1156
	Weldon	7-1010-1		1156
Stop	Weldon	1010	Red	1156
	Arrow	438		1157
	Signal Stat	1605		1156
	KD	772-9105		1156
Destination Sign				89
School Bus Sign				TS93

# DORAN WARNING LIGHT MONITOR

The Doran monitor is a current-monitoring device; therefore, if current is flowing through one of the bus lamp circuits, the monitor senses this and lights the corresponding monitor bulb. If the bus lamp burns out, current ceases and the corresponding monitor bulb goes out indicating a fault. (See schematic illustration Page 18 showing A Typical Monitor Circuit).

The Doran monitor is a reliable, long-life device, but as with most electrical instruments, it can be overheated and damaged if an overload occurs in a bus light. Such overloads can exist if a bus light circuit becomes shorted, forcing current through a coil in the monitor which exceeds its rated capacity. Short circuits can occur if improper connections are made during installations, during bus repairs, etc. If the monitor has an optional thermistor overload protection, the tail light circuits are overload protected (thermistors are located on the bottom of the component side of the P.C. Board).

This repair instruction is intended to assist qualified repair personnel to diagnose, remove, repair and reinstall monitors, which have become inoperative due to a variety of conditions.

## REPAIR PROCEDURE

**NOTE:** Field repair is not intended for monitors covered by Blue Bird Body Company warranty. Inoperative monitors under warranty should be returned to Blue Bird Body Company for repair or replacement under the terms and conditions of warranty for electrical parts.

- Step 1: MOST IMPORTANT! Carefully note and record exactly which monitor lamps are not operating properly. Include this information on a tag to be attached to the monitor after removal from the bus panel.
- Step 2: Disconnect bus battery.
- Step 3: Remove mounting screws, which attach the monitor to the bus panel, being careful not to accidentally pull any connecting wires loose.
- Step 4: Remove one connecting wire at a time from monitor terminals, tagging EACH WIRE with the terminal number shown on the monitor.
- Step 5: If a spare monitor is to be installed at this point, record the monitor serial number for your future reference. The number is shown on both the protective fiberboard back plate and on the monitor printed circuit board.
- Step 6: With the monitor removed from the bus and to a repair bench, remove the four nuts to remove the monitor PC board from the face plate. Pull the protective fiberboard backing from the terminals, being careful not to bend or tear it; retain for later use.
- Step 7: Locate the components to be replaced by referring to Diagram of Coils and Reed Switches on Page 16. Locate the solder points for these components.
- Step 8: Replace the inoperative coil/reed switch assembly as follows:
  - a. With wire clippers cut the reed switch leads (2) and the coil leads (2) as close to the board surface, as possible. (If a tail lamp monitor is to be replaced, pull the protective shield loose and retain for reuse later).
  - b. With soldering iron, CAREFULLY melt-out the remaining coil and reed switch leads from the solder side of the board, pulling gently on the leads with tweezers. With the lead stubs removed, touch the holds in the PC board with soldering iron to "clear" them for replacement lead insertion.
  - c. Insert replacement coil and reed switch leads, guiding them into proper holes with index finger and thumb. Hold coil snug to the board while leads are bent over the solder side of the board. It is recommended that excess leads not be clipped until after soldering is completed. This will help to minimize shock or vibration on the reed switch, when leads are later trimmed. (Reed switches are encased in a fragile envelope and should be handled carefully to avoid chipping of envelope or distortion of leads).
  - d. Place a bead of solder on the remaining lead ends, being careful not to interfere with other nearby solder points or PC paths.

Step 9: If a tail lamp has been replaced, clean the original sealant from the protective shields and reinstall with new Silicone rubber sealant as recommended.

Step 10: Visually examine all other components, leads, PC paths and LED's for any remaining problems to be corrected. Reinstall monitor in bus, making sure battery is disconnected and that wires are reconnected to the monitor in the same order as shown in chart on page 18.

If additional instructions are needed after following the above procedure, contact Blue Bird Body Company.

## **DIAGNOSIS**

### **Condition A**

If ALL lights on the monitor are inoperative, even though the exterior lights on the bus operate properly, and all connections are still intact, the causes may be:

1. Overloading or physical damage has burnt or broken a path on the printed circuit board. (It is not considered practical to attempt field repair of printed circuit board paths, and a replacement monitor is recommended).

### **Condition B:**

If a particular light is inoperative, even though the corresponding exterior bus lamp operates properly, and all connections to the monitor are intact, the cause may be:

1. A burned-out coil or inoperative reed switch. Burned-out coils can usually be visually detected by a blackened appearance, when the monitor is removed from the bus. If a burned-out coil has not scorched the board and distorted a PC path, a replacement coil/reed switch kit can be installed. (Available through your usual Blue Bird service parts source).
2. A loose connection in one or both leads of the light emitting diode (LED) on the monitor. LED's seldom fail unless they are installed with incorrect polarity or have suffered physical damage. The LED recessed design of face plate protects against normal usage. (LED's CAN be ruined by Ohm meters, and care must be taken to avoid the use of such meters).

The cause of an inoperative LED will generally be found in monitor and bus circuits other than at the LED; however, if an LED itself is known to be inoperative, contact your usual Blue Bird service parts source for special handling of replacement LED's.

### **Condition C:**

If a monitor light stays on even when the exterior light of the bus is turned off, the reed switch located inside of the monitor coil is not operating properly. This can be repaired in the field by replacing the coil and reed switch (available in a preassembled unit from Blue Bird Body Company) - see Condition B, Item 1, above.

### **Condition D:**

If the tail light monitor and exterior tail lights fail to operate, the cause may be:

1. Tail light bulbs may need to be replaced.
2. An over current situation. In this case, the thermistor has protected the entire circuit. Remove power from the circuit and monitor, repair over current and reconnect.

Some causes of over current:

- A. Dead short,
- B. Wrong tail light bulb, and
- C. Parallel wiring of additional tail lights.

## **TOOLS AND SUPPLIES REQUIRED FOR REPAIR**

- Hand tools as required to remove mounting screws at bus panel.
- Tags suitable for use in marking connecting wires, and also for recording the monitor problem.
- A 30 or 40 watt soldering iron for electronic repair (do not use a 100-watt "shop" iron).
- Small wire clippers.
- Pointed tweezers (Clauss #225, or equivalent).

- 60/40 resin core solder, .031 or .062 thick (Kester "44" or equivalent).
- Replacement coil/reed switch kits. (Note that coils for bus warning lights are 10-turn coils; those for tail lamps are 50-turn coils, and those for back-up lights, turn signals, and stop lights are all 16-turn coils. The proper coil MUST be used in replacement.

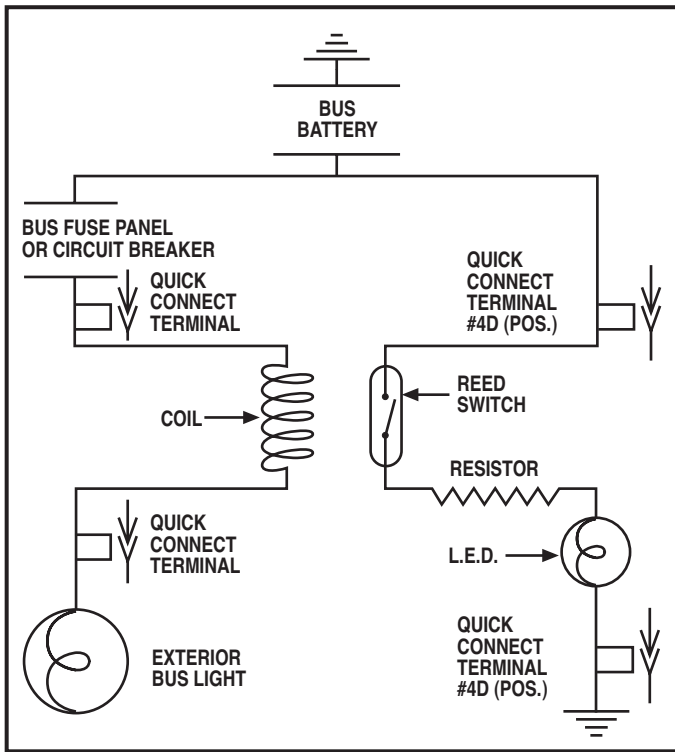

DORAN EXTERIOR LIGHT MONITOR  
(A Typical Circuit)

Connection	Lamp Function	Model:	Monitor				
			A	B	C	D	E
4A	RED WARNING LAMP RIGHT INPUT		X	X	X	X	
1A	RED WARNING LAMP RIGHT FRONT OUTPUT		X	X	X	X	
6A	RED WARNING LAMP RIGHT REAR OUTPUT		X	X	X	X	
2A	AMBER WARNING LAMP RIGHT INPUT			X	X		
3A	AMBER WARNING LAMP RIGHT FRONT OUTPUT			X	X		
5A	AMBER WARNING LAMP RIGHT REAR OUTPUT			X	X		
4B	RED WARNING LAMP LEFT INPUT		X	X	X	X	
1B	RED WARNING LAMP LEFT FRONT OUTPUT		X	X	X	X	
6B	RED WARNING LAMP LEFT REAR OUTPUT		X	X	X	X	
2B	AMBER WARNING LAMP LEFT INPUT			X	X		
3B	AMBER WARNING LAMP FRONT			X	X		
5B	AMBER WARNING LAMP LEFT REAR OUTPUT			X	X		
3C	TURN SIGNAL LAMP RIGHT REAR OUTPUT				X	X	X
4C	TURN SIGNAL LAMP RIGHT REAR INPUT				X	X	X
2D	TURN SIGNAL LAMP LEFT REAR INPUT				X	X	X
3D	TURN SIGNAL LAMP LEFT REAR OUTPUT				X	X	X
1C	STOP LAMP - INPUT				X	X	X
2C	STOP LAMP RIGHT - OUTPUT				X	X	X
1D	STOP LAMP LEFT - OUTPUT				X	X	X
7D	TAIL LAMP - INPUT				X	X	X
7C	TAIL LAMP RIGHT - OUTPUT				X	X	X
8D	TAIL LAMP LEFT - OUTPUT				X	X	X
6C	BACK-UP LAMP - INPUT				X	X	X
8C	BACK-UP LAMP RIGHT OUTPUT				X	X	X
5D	BACK-UP LEFT - OUTPUT				X	X	X
CONNECT LAST:							
4D	12 V DC POWER		X	X	X	X	X
6D	GROUND		X	X	X	X	X
5C	OPEN		X	X	X	X	X

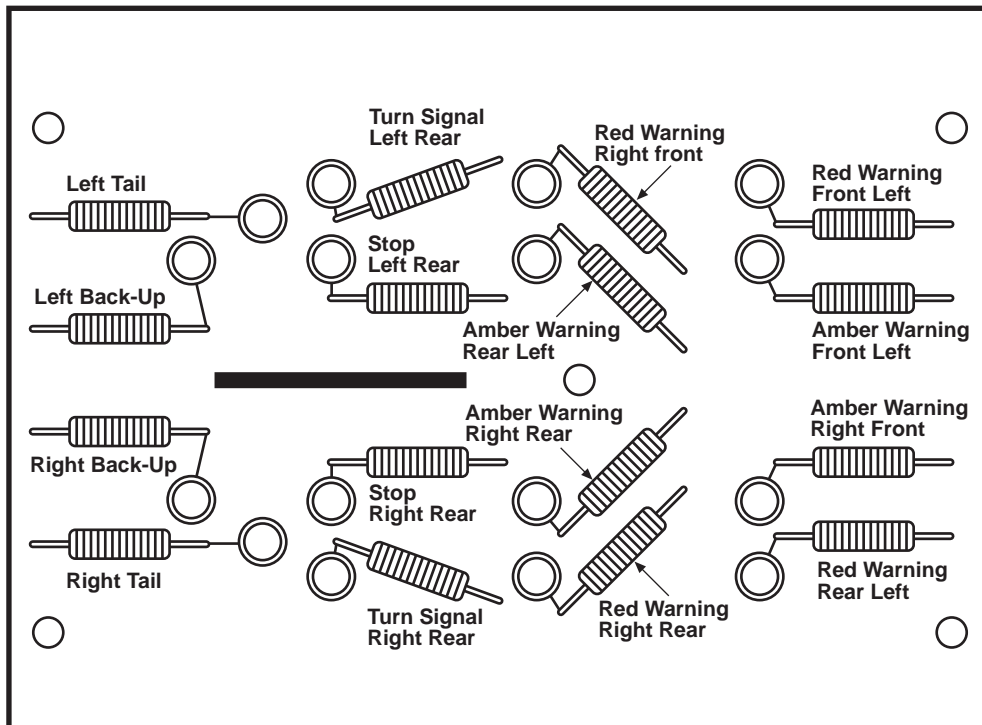

DORAN EXTERIOR LIGHT MONITOR  
Diagram of Coils and Reed Switches with Indication of the L.E.D.'s they Control

## CIRCUIT BREAKERS

Body circuits are protected by circuit breakers located in a side mounted electrical box below driver's window. If a current overload or short should occur in any body circuit, it will trip the circuit breaker. If a short occurs and the circuit breaker breaks, the circuit breaker will reset itself when the element cools in about 15 seconds. A short may be indicated by blinking of lights or fluctuating gauges. The shorted circuit should be corrected immediately. Refer to body or chassis master wiring diagrams provided with vendor information.

For access to the electrical panel, locate release latch as shown. Push latch release downward. This will enable the access door located on the outside of bus below the driver's window to open.

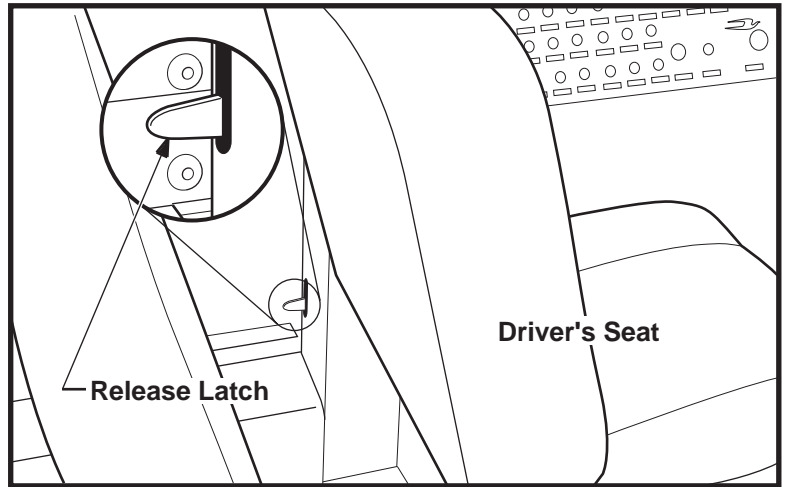

**NOTE:** Use of appropriate amperage circuit breaker required.

## MIRRORS & MIRROR ADJUSTMENT

**WARNING: The vehicle's mirror system has been designed to comply with all field of view requirements, but it is the owner's responsibility to adjust the mirrors properly before placing the vehicle in service and to maintain the adjustment during the service life of the vehicle. Mirrors provide additional driver visibility on buses. To be effectively used mirrors must be properly adjusted for each driver and the driver must be aware of the limitations on viewing area that exists even when mirrors are properly used. Mirrors are not a substitute for proper driver training and the exercise of driver care in operating the vehicle and loading and unloading of passengers. Do not move the bus until you have accounted for each passenger that has disembarked and have confirmed that the passenger is clear of the bus. Failure to follow these procedures could cause serious injury or death.**

Right front convex crossview and right and left front convex rearview mirrors are required equipment on all TC, Type (D), buses. Left front convex crossview mirrors are also available.

### INTERIOR MIRRORS

Inside rearview mirrors are adjustable by loosening the bolts and nuts in slotted holes. Adjust the mirror to afford the operator a good view of bus interior and roadway to the rear.

**WARNING: Many school bus passengers are energetic children who are small and playful and do not understand the hazards of buses. After unloading, some children could be outside the field of vision of your mirrors or could quickly dart into such a place. Do not move your bus after unloading passengers until you have confirmed the location of every child who got off and have confirmed that each child is completely clear of the bus. Failure to follow this procedure could cause serious injury or death.**

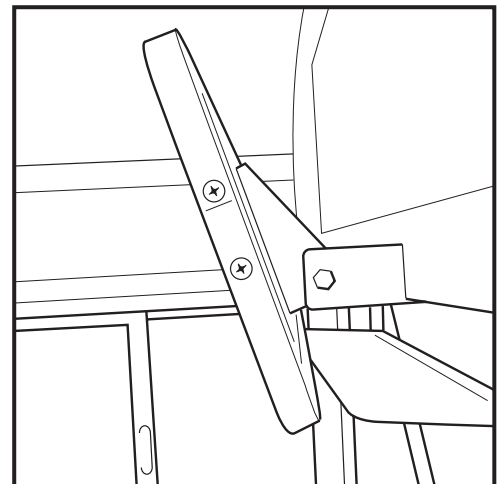

## 8" DIA. SUPPLEMENTAL EXTERIOR REARVIEW MIRROR

Some units may be equipped with two (2) 8" elliptical mirrors, one on the LH side and one on the RH side, which are designed to supplement the view provided by the outside rearview driving mirrors. The RH 8" elliptical mirror is attached to the RH outside rearview mirror mounting bracket as illustrated, and is viewed through the RH windshield. The LH 8" elliptical mirror is attached to the bus body and is located so as to be viewed through the LH windshield.

Proper adjustment is necessary for any mirror system to perform as designed. The following adjustment should be used to allow the driver to obtain the maximum viewing area with the mirror system.

Position the RH 8" elliptical mirror in the location illustrated. Adjust the 8" elliptical mirrors on both the RH and LH side to provide the seated driver a view of the ground directly below the outside rearview driving mirrors, and rearward to overlap the view provided by the outside rearview convex driving mirrors.

**CAUTION: A convex mirror has a curved surface and is designed to provide a wide view with minimum distortion. However, persons or objects seen in a convex mirror will look smaller and appear farther away than when seen in a flat mirror or viewed directly. Therefore, use care when judging the size or distance of a person or object seen in a convex mirror. Wait until you can view the person or object in a flat mirror or direct view to determine their size and distance.**

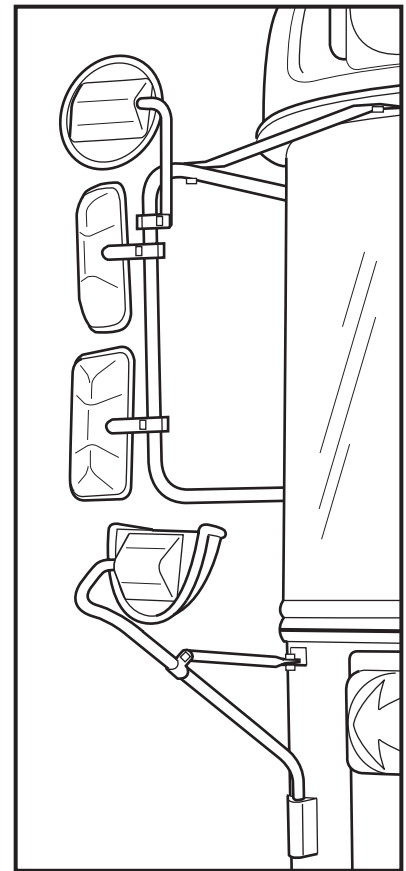

## EXTERIOR REARVIEW

Standard equipment on all school buses is comprised of 4 outside rearview driving mirrors. (2 per side), and 2 elliptical crossview mirrors, (1 per side). The outside rearview driving mirrors include (1) 6.5"x 10" flat mirror and (1) 6.5"x10" convex mirror each side. The outside rearview driving mirrors are designed to provide the seated driver a view of the roadway to the rear and to the sides of the bus. The elliptical crossview mirrors are designed to provide a seated driver a view of all areas around the front of the bus not directly visible to the driver. The elliptical crossview mirrors are designed to be used to view pedestrians while bus is stopped. **DO NOT USE THE ELLIPTICAL CROSSVIEW MIRRORS TO VIEW TRAFFIC WHILE BUS IS MOVING. AS IMAGES IN SUCH MIRRORS DO NOT ACCURATELY SHOW ANOTHER VEHICLE'S LOCATION.**

Proper adjustment is necessary for any mirror system to perform as designed. The following adjustment sequence should be used to allow the driver to obtain the maximum viewing area with the mirror system.

1. Adjust the driver's seat to the desired position.
2. Adjust the RH flat driving mirror so that the tops of the side windows are visible in the upper edge of the mirror, and so that the RH side of the bus body is visible in the inside edge of the RH flat mirror.
3. Adjust the RH convex driving mirror so that the view in the top of the convex mirror overlaps the view provided by the RH flat driving mirror, and so that the RH side of the bus body is visible in the inside edge of the RH convex mirror.
4. Adjust the LH flat driving mirror and the LH convex driving mirror following the same procedures described for the RH mirrors. Refer to steps #2 and #3 above.

5. Adjust the elliptical crossview mirrors by positioning each mirror head so that the "arrow" embossed in the top of the elliptical mirror housing is pointed directly at the eyes of the seated driver.
6. A final adjustment should be made to the mirror system so that the seated driver can view the areas required by FMVSS 111, including the entire top surface of cylinders M and N when located as illustrated and rearward a minimum of 200 feet (measured from the mirror surface) using the outside rearview driving mirrors. The elliptical crossview mirrors should be adjusted to provide the seated driver a view of the entire surface of any cylinder A thru P (when located as illustrated) not visible by direct view of the driver. The view provided by the elliptical crossview mirrors must overlap the view provided by the outside rearview driving mirror system.

**Maintenance:** All mirrors should be cleaned weekly or more often if conditions warrant. Cleaning should be done with an ammonia solution to insure that mirrors are not obstructed. Be sure that mounting fasteners are kept tight so that mirrors will not vibrate. Check weekly and retighten, if necessary.

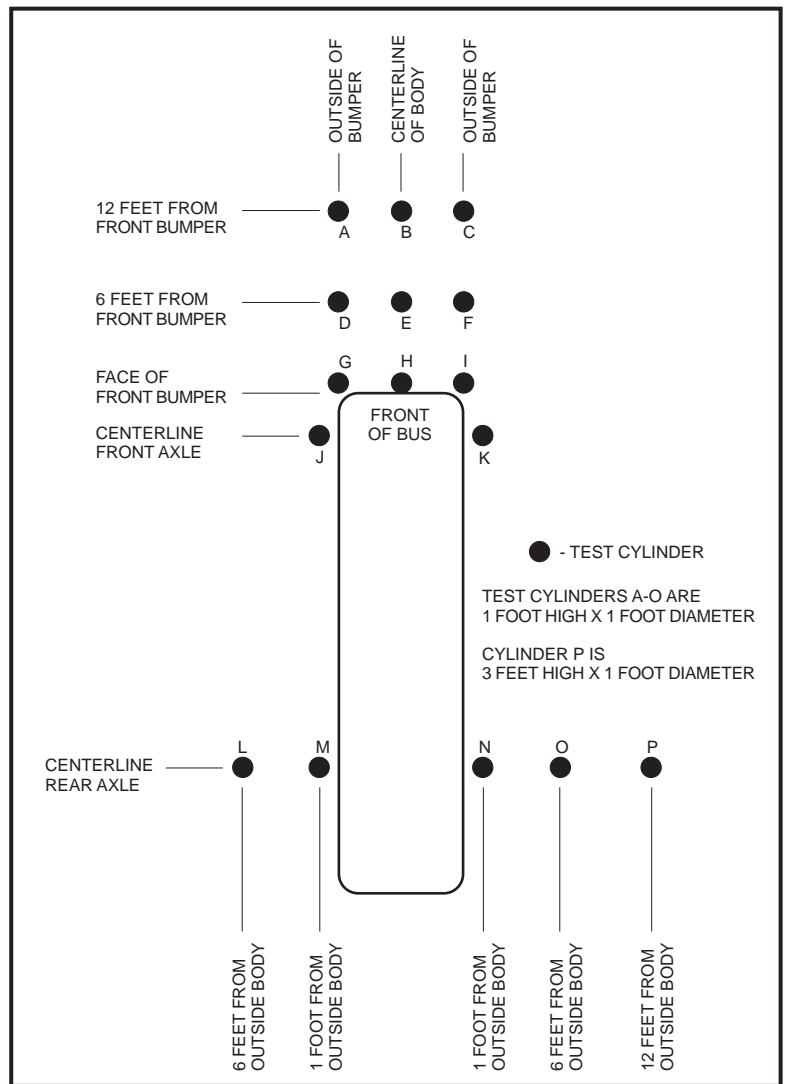

## EMERGENCY EQUIPMENT

### FIRST AID KIT

The first aid kit is mounted in the front of the bus body just above the right windshield. The contents of the kit should be inspected weekly or as required by local regulation to be sure that all contents comply with state specifications.

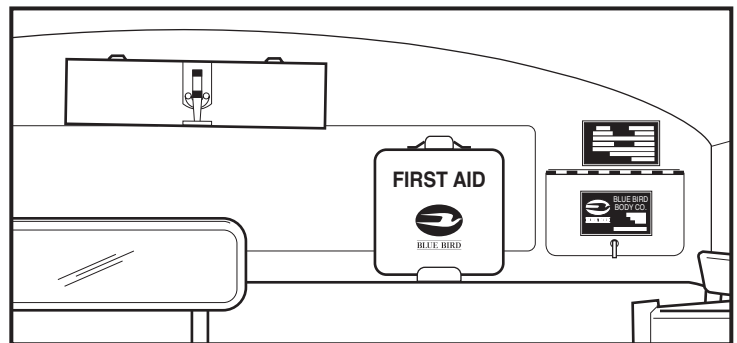

### FIRE EXTINGUISHER

The fire extinguisher is normally located on the right-hand sidewall between the grabrail and barrier. Your unit may be equipped with either a 2 3/4, 4 1/2, 5 or 6 pound extinguisher. Inspect the pressure gauge every 30 days or as required by individual state fire laws to insure that the unit is fully charged. Inspect mounting fastener periodically to be sure they are tight.



## FIRE AXE/CROWBAR

The fire axe and crowbar are located on the electrical panel access cover to the left of the driver's seat as close to the front as possible every 30 days, inspect installation mounting fasteners to insure that they are tight. Check fire axe and crowbar monthly to be sure that they are easily accessible and unobstructed.

## FLARE KIT

The flare kit is mounted on the left-hand side panel behind the driver's seat. Insure that the contents of the flare kits are in place every 30 days or as required by local regulations. Inspect mounting fasteners for flare kit box every 30 days to insure that they are tight.

## TRIANGULAR WARNING DEVICE

For states requiring the triangular warning devices to be located in the driver's compartment, this container is mounted above the windshield at the upper center near the roof line. For other states, it is located on the left-hand rear floor board under the rear seat. Inspect contents of the kit every 30 days or as required by local code to insure proper operation.

In units with optional locking emergency equipment in the front upper panel above the windshield, all equipment is located behind the access door which is labeled with a list of the equipment. To meet state specifications, the door locking mechanism is connected to a buzzer system. The buzzer sounds when the ignition is turned on and the compartment is locked.

On the Rear Engine models the triangular warning device, encased fuses, fire extinguisher, fire axe and wrecking bar are located in the front of the bus body in the center compartment at the floor depending on the options.

Your unit may be equipped with a 2 3/4, 4 1/2, 5 or 6 pound fire extinguisher. Periodic inspections are needed.

## RECOMMENDED WARNING DEVICE POSITIONING

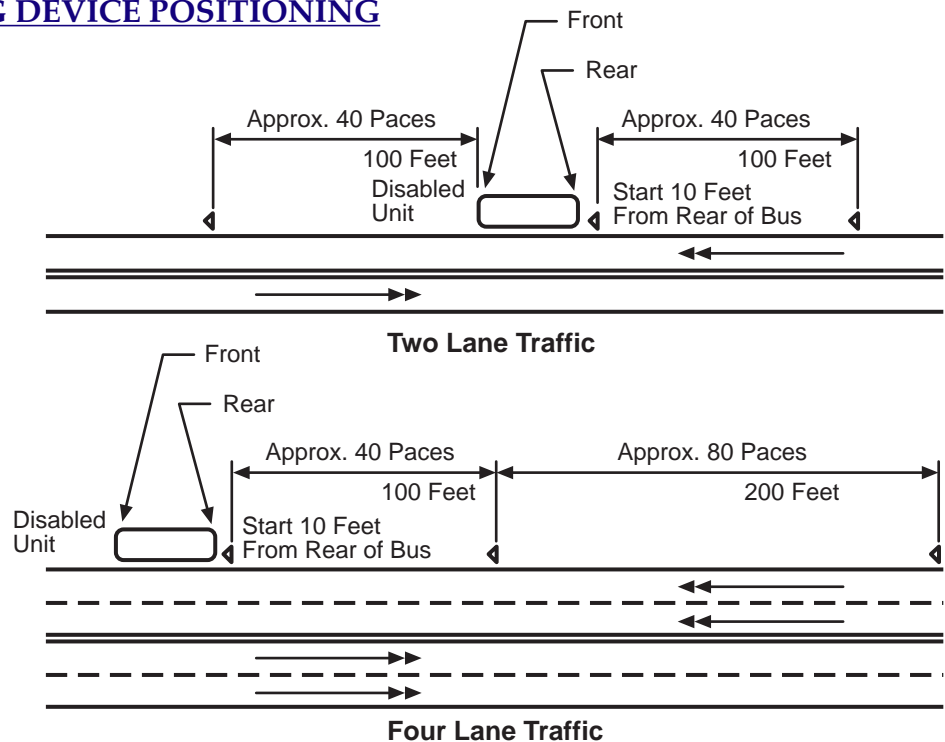

# EMERGENCY EXITS

Emergency exits are clearly identified by the words “Emergency Exit.” Operating instructions are written close to each exit. Some units are equipped with an audible alarm device signifying an emergency exit is unlatched or open. If, when turning the ignition switch on, a buzzer sounds, check emergency exits to see that they are completely closed. All emergency exits meet Federal Motor Vehicle Safety Standard 217 “Bus Window Retention and Release.” These illustrations show various types of emergency exits.

All emergency exits should be inspected and operated daily to insure they are labeled and operate properly per the instructions provided.

Also see Transpec Safety Vent.

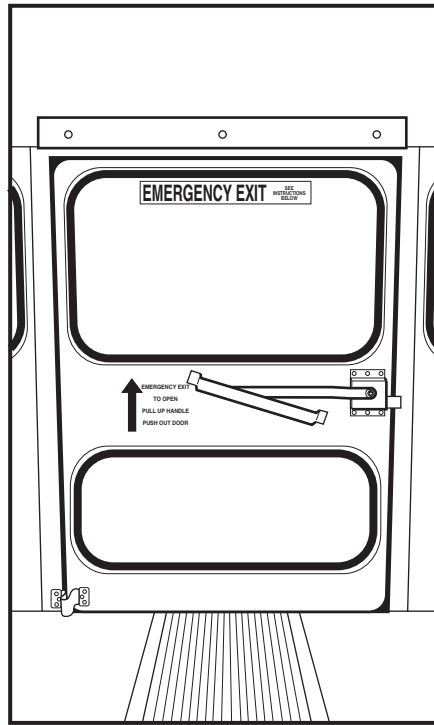

Rear Emergency Door

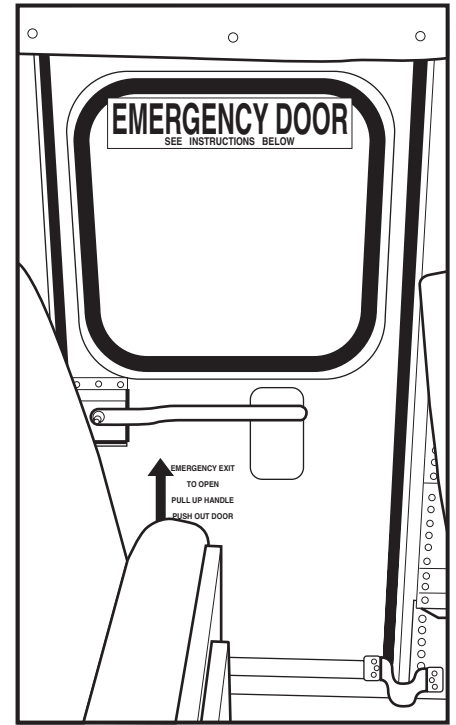

Side Emergency Door



Split Sash Pushout Window

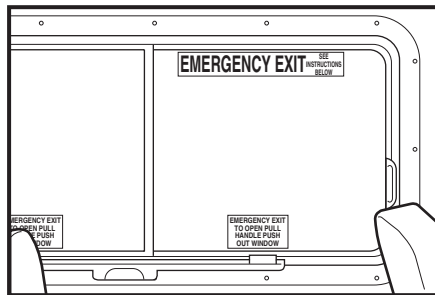

Transit Sliding Pushout Window

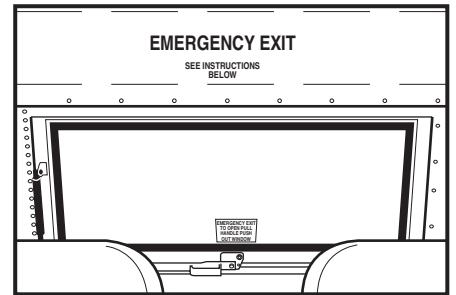

Rear Emergency Window

# WHEELCHAIR LIFTS

For the TC, Blue Bird supplies lifts from Braun and Collins. Each vendor provides its own publication for information on maintenance, lubrication, troubleshooting and other important items that are imperative to the smooth operation and safety of wheelchair lifts. These publications are supplied with vendor maintenance documents per order.

Illustrated is the wiring diagram of the buzzer circuits for the wheelchair lift door. The buzzer indicates whether the door is unlatched, opened part of the way, or opened completely (at which time buzzer does not sound).

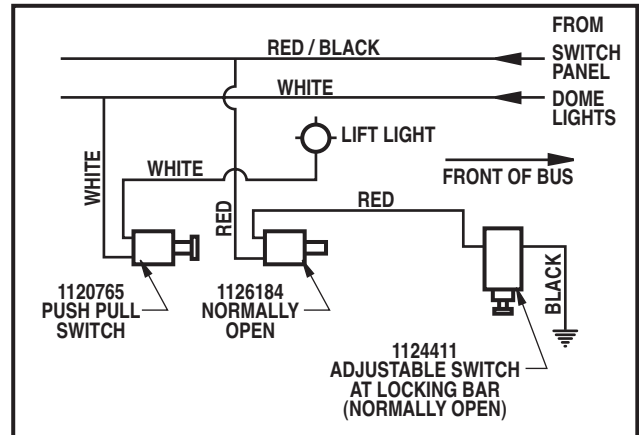

# TRANSPEC SAFETY VENT

## MAINTENANCE CAUTIONS

Transpec Safety Vents are designed to provide years of reliable service with a minimum of maintenance. All components are rust proof with life time finishes, and moving parts are Teflon coated to eliminate need for lubrication. Use of lubricants, paints, or other coatings-such as graffiti deterring spray-is not recommended.

Suggested maintenance includes periodic inspection of attaching fasteners for evidence of loosening due to tampering, and regular cleaning with mild soap and water. Although there are other cleaning solutions available, some of them contain solvents and other chemicals that can attack the high strength materials used in the production of safety vents.

It is the customer's responsibility to ensure that cleaning solutions are compatible with the materials used on safety vents.

Graffiti removing cleaners often contain acetone, ether, lacquer thinner, or other solvents known to destroy the high strength properties of many engineering plastics and use of these cleaners must be avoided. Graffiti resisting coatings often leave a sticky residue that interferes with smooth up / down movement of the ventilator mechanism. Some of these coatings also contain solvents that will reduce the strength of certain components. Use of these coatings on safety vents is at considerable risk and should be avoided.

## SERVICE AND REPAIRS

All components used in the production of Safety Vents are available as service parts, except for one hinge that represents a possible hazard when improperly reattached to a hidden tapping plate that is often damaged, whenever the hinge is damaged. The tapping plate is permanently laminated between the inner and outer cover assemblies and can neither be inspected nor replaced. It is, therefore, necessary to replace the entire assembly following damage to the hinge.

**CAUTION: Hinge assembly is critical and hinge should never be removed from cover assembly. Fasteners used in this assembly are special and have critical torque requirements and tamper resistant heads to discourage tampering.**

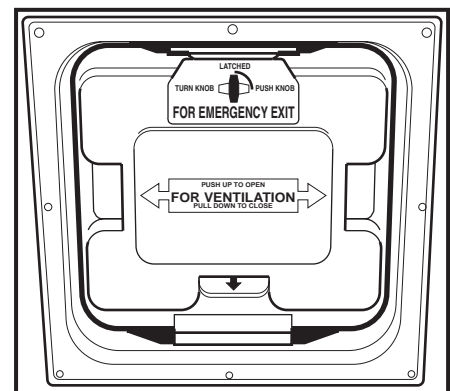

Roof Hatch

# STOP ARMS

Stop arms are required on Blue Bird TC school buses per FMVSS 131. Stop arm assemblies are purchased as a kit; many different kits are available with blades to meet all state requirements. The stop arm is located on the left-hand side of the body under the driver's window. Stop arms are most commonly operated by a manual switch located in the switch panel.

For air stop arms the manual switch activates an electric solenoid valve controlling the flow of air. Optionally, the solenoid valve may be activated by the warning lamp system. This system works in conjunction with the air system on the chassis. No preventive maintenance procedures are required with these systems.

With the electric stop arms the manual switch activates the control relay of the stop arm. Optionally, the stop arm may be activated by the warning lamp system. The following preventive maintenance procedures should be followed for the electric stop arm.

## Monthly

- Oil the dual-action breakaway hinge at four (4) pivot points with a high performance, penetrating lubricant. Tri-Flow™ (DuPont) with teflon is recommended.
- Check and make sure breakaway portion of hinge is free and movable.
- Check fasteners for tightness.

## Quarterly

- Remove front and rear covers of base and check internal fasteners for tightness.

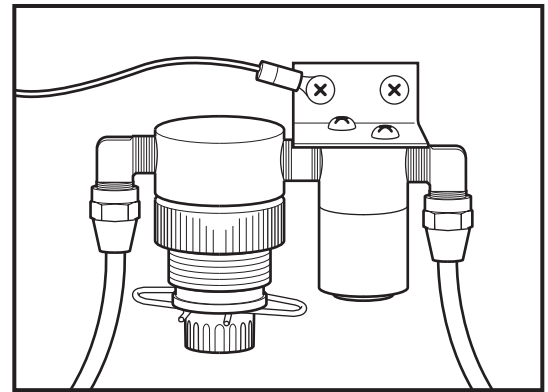

AIR REGULATOR

On units equipped with air stop arms, the air pressure may occasionally require adjustment to insure proper opening and closing of the stop arm. Air regulator is accessible by opening the electrical panel door outside under the driver's window. Regulator is identified as shown. To regulate the air pressure, remove the wire retaining clip below the regulator knob and pull the red lock ring out. Turn the knob counterclockwise to decrease the pressure, then slowly increase the pressure (turn knob clockwise) until the stop arm hinge is extended to approximately 90 Degrees. Relock knob by pushing in the red lock ring and reinstalling wire retaining clip.

The "STOP" sign must extend and if equipped with lights, the lights must be operating at anytime the red lights of the warning light system are flashing. There are some unique, state-designed warning light/stop arm systems that permit the stop arm to be withdrawn while warning lights are in operation. For those situations an audible alarm sounds to alert the driver of the condition.

## AIR STOP SIGNS AND CROSSING ARM TROUBLESHOOTING

### AIR STOP SIGNS AND CROSSING ARMS

#### Problem:

Signs won't open to 90 Degrees.

#### Areas to Check:

1. Faulty diaphragm - same as above.
2. Faulty solenoid valve - same as above
3. Air pressure regulator - air pressure regulator must precede the solenoid to prevent damage to the solenoid or to the diaphragm. Excessive pressure may cause damage to both the solenoid and the diaphragm. Pressure should not exceed 12 lbs.

4. System leak - check to make sure that the air pressure supplied to the solenoid valve or the diaphragm is equal to 10 to 12 lbs. Again - CAUTION - not to exceed 12 lbs. of pressure is very important. Excessive pressure will cause damage to the diaphragm and the solenoid valve.
5. Loose fasteners - same as above.

**NOTE:** Solenoid valves must be checked under pressure while activation of the electric solenoid is taking place.

### **ELECTRIC STOP SIGNS AND CROSSING ARMS:**

In order to troubleshoot an electric stop sign or crossing arm it is important to first understand how to install the stop signs and crossing arms. The electric installation can be accomplished in two different manners.

#### **Example #1:**

- A. Dark blue to a switched 12V terminal. Red to a constant 12V terminal. Green to a proper ground. This example would use the blue wire to activate the stop sign and to deactivate the stop sign.

#### **Example #2:**

- B. Dark blue and red to a constant 12V terminal. Green to a grounded switched terminal. Example #2 would use the green wire or the ground to activate and deactivate the stop signs or crossing arms.

One of the major features of the electric stop signs and crossing arms is that all of the works are in the base. You can troubleshoot the electric stop sign by first:

- (A) Determining if the proper wiring installation has been achieved and that 12V and ground are available where required.
- (B) Remove the rear cover of the base.
- (C) Remove the red wire from the relay (wires lead to terminal on motor).
- (D) Remove red wire from the limit switch.
- (E) Replace the red wire on the limit switch with the red wire from the motor.
- (F) With a battery charger or any other 12V source ground the motor terminal (black wire) and attach the positive 12V to the red wire terminal on the motor. The motor should begin to activate and run continuously until you remove the red wire.
- (G) With a probe attached to the 12V positive side of the battery charger identify the black and light blue leads on the limit switch at the motor base and with a 12V positive probe select either the black or the light blue terminal and attach the probe to the lead of the limit switch. One of two conditions will occur - either the motor will begin running or it will not. If the motor runs it should proceed until the CAM circles and deactivates the limit switch causing the motor to stop. At that time switch terminals with the limit switch to either the black or light blue depending on where you started and again the motor should begin to run until the CAM positions itself to deactivate the limit switch. If both these points prove to operate the motor then the limit switch, CAM and motor assembly are functioning. If you have verified that you have the proper wiring installation as identified in the opening paragraph then your problem rests with the relay. Replace the relay. This should render the sign operational again.

## **STOP SIGN BLADE FAILURE**

### **Problem:**

Lights do not function.

### **Areas to Check:**

1. Check to insure that the light bulb is working.
2. Check to insure that the ground strap is secure.
3. Check to see if 12V is being supplied to the light bulb.

It is important to note that there have been improvements made to the socket and pigtail. The improvements are as follows:

- A. Screws versus rivets make replacement possible with a common nut driver.
- B. A two-wire socket and pigtail eliminated the braided wire ground strap which on occasion failed in the field. This will help insure that the ground is intact throughout the operation and life of the sign.
- C. Lower temperature protection (minus 40-wire and vinyl tubing) have been added to insure a broader temperature range in northern and southern climates.

### **Problem:**

Fading to the blade surface.

### **Areas to Check:**

1. Steel blades are painted with a red paint, which are prone to bleaching due to the pigments. If the blade becomes faded possible solutions are to repaint or replace the blade. Specialty recommends the replacement of the blade due to the labor savings and cost efficiency. Approximate cost of replacement blades on a steel blade is \$8-10 depending on the quality.
2. Aluminum reflective signs have improved in technology to the point where blades in southern exposures are now lasting five to seven years. This is due to ink improvements where the pigmentation in the inks actually darkens over the life of the sign. Replacement now is due to sub-straight failures on Engineering grade versus ink failures as in the past. Decals are available for Engineering grade and high intensity sign runs you approximately twice as much as a steel blade. All of our products; air, vacuum and electric are available with a high intensity face.

## **WINTERFRONT COVER**

---

The winterfront cover design for charge-air-cooled TCFE engines beginning in 1991 is slightly different from previous winterfronts. A minimum of 120 square inches of area must remain open at all times. Therefore, do not attempt to cover the air inlet holes in the headlight panel while the winterfront cover is on the top grille panel.

Keep a watchful eye on the engine coolant temperature gauge at all times when the winterfront is in place. If the engine temperature begins to rise above normal and/or the shutters begin to stay open, remove the winter front cover.

## FRONT ACCESS PANELS

---

To service components behind or underneath the dash area, access can be gained through the front access panels by the following procedure.

Release press button latches on center panel and allow panel to open downward. This allows access to heater bleeding valve, radiator fill cap and view to radiator sight glass.

Release press button latches on front access doors to the left and right of the center panel for access to windshield wiper motors, windshield wash reservoir (located behind the driver's side headlight), power steering fluid reservoir and radiator overflow reservoir.

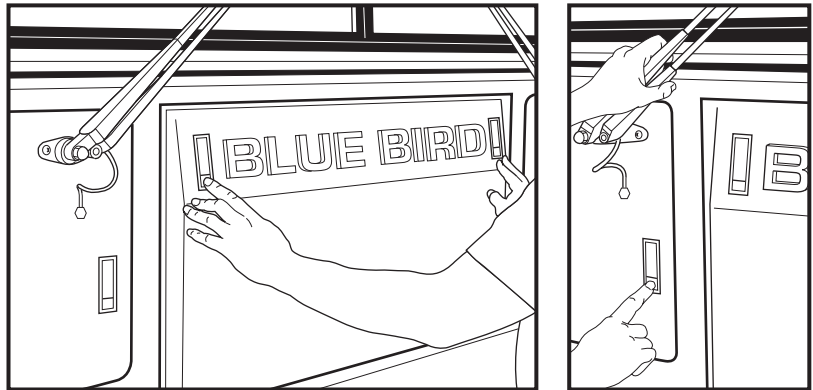

## ACCESS DOORS

---

In order to prolong the life of access door latches, locks and hinges, periodic maintenance should be performed as follows. Once per week, clean and inspect the door hinges and latch mechanisms. Clean with a nonabrasive degreaser or cleanser as required. Every three months lubricate with either a graphite-type lubricant or a spray-type lubricant such as LPS. The following is a list of access doors, which require these maintenance procedures.

1. Battery Compartment Door
2. Luggage Compartment Door
3. Tire Compartment Door
4. Fuel Fill Door
5. Radiator Fill Door
6. Side Electrical Panel Door
7. Left and Right Hand Front Access Doors

Glove compartment and emergency equipment doors should be inspected on a daily basis. Open and close to insure proper operation. If necessary, follow the same lubrication procedure as outlined above.

## BODY TIE-DOWN

Tighten the tie-down clamp bolts and body shear bolts at 1500 miles and quarterly thereafter to 37-41 ft. lbs. of torque.

There are eight shear bolt locations. One shear bolt is located on the right front outrigger under the body. Another is on the left corner post tie-down channel under the body. Two shear bolts are located just behind the front suspension, one on each frame rail tie-down angle. The last four are at the rear of the body floor in the chassis outriggers. The body is mounted with pads of high-durometer rubber between the floor and chassis frame rails. The rubber absorbs shock, deadens sound and maintains tension on the tie-down clamps. Be sure pads are in place when tightening tie-down bolts.

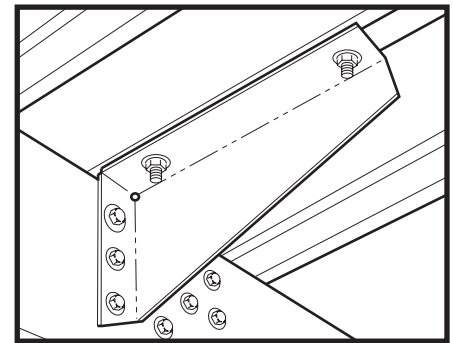

MTG. BOLTS IN OUTRIGGERS

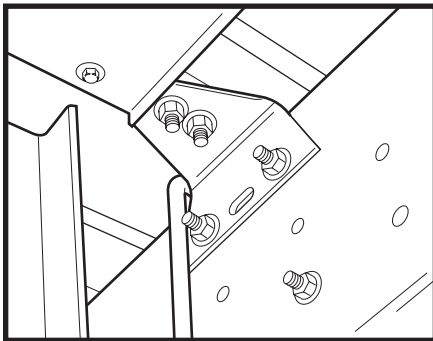

TIE DOWN BRACKETS

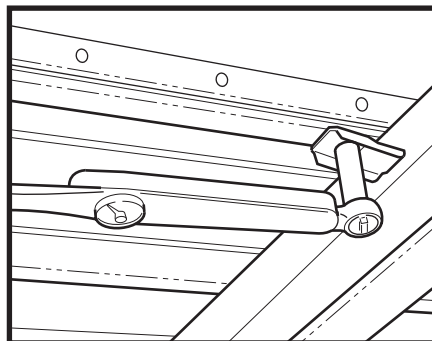

TIE DOWN CLAMP BOLTS

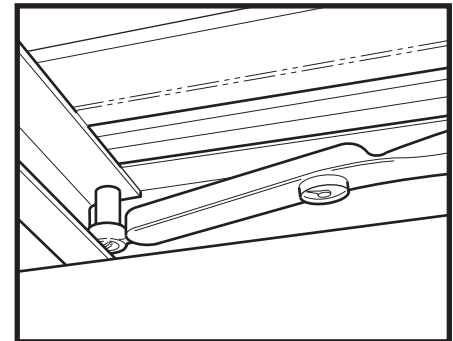

MOUNTING BOLTS AT REAR NEAR BUMPER

**WARNING:** Failure to follow the procedures for tightening bolts, either by failure to tighten on schedule or by failure to conform to the torque poundages, could create a danger of separation of the body and chassis, thereby causing possible personal injury or death.

## TOWING OR PUSHING

**CAUTION:** Never tow or push a vehicle equipped with Allison automatic transmission, until the rear drive shaft has been removed, or unless the rear wheels have been raised off the ground. Do not tow by front axle. Bus may be towed using front or rear bumper brackets. Optional tow hooks are located at the front and/or rear of the vehicle under the bumper. Tow hooks are designed to tow or pull with both hooks simultaneously. Do not pull or tow with an individual hook. Bumpers provided on Blue Bird buses are designed to protect the vehicle and occupants from front and rear collisions. TC bumpers are designed for use with bumper jacks. Do not work under bus when supported by bumper jacks. Use only appropriate jack stands supporting frame rails when under bus.

**WARNING:** Extreme caution should be exercised when the drive shaft is removed on a unit equipped with hydraulic brakes. The parking brake becomes inoperative when the drive shaft is disconnected. Do not leave the bus unattended until appropriate measures have been taken to prevent vehicle movement. Do not work under bus when supported by bumper jacks. Use only appropriate jack stands supporting frame rails when under bus.



# DOORS

---

## CONTINUING MAINTENANCE REQUIREMENTS

1. Keep working parts of control tightened.
2. Lubricate all working parts periodically, including hinges and overhead controls. (See Body Component Maintenance Chart)
3. Repair or replace worn seals.
4. Maintain proper door opening and closing adjustment. (See Body Component Maintenance Chart)

## OUTWARD OPENING

Doors are mounted in a prefabricated framework which eliminates effect of body construction variations on door and seal operation. Doors are suspended completely on scaled ball bearings located at the top corners of the framework, inside the body. The interlink connection between the doors is a single assembly with oppositely threaded spherical bearing rod-end connectors on each end providing simple link length adjustment without disassembly. Simply loosen the lock nut, turn the tube, and retighten the nut when satisfactorily adjusted. The geometry of the mechanical link between the doors causes the rear door to close well ahead of the front door, so that the front nosing seal rubber always overlaps the rear. Oil impregnated bronze bearings serve as pivots, not supports, in the lower corners of the framework. All controls and mechanisms and the complete lower step tread are sealed inside the bus and out of the weather when the door is closed.

In the interest of safety through maximized driver visibility, the doors have been designed to have as much clear glass opening as possible. A four inch wide pad is mounted to the header cover over the opening.

The manual control is the Blue Bird cover over center locking type with built-in saf-latch. The door ease-of-operation facilitates use of a short handle arm, so the handle is six inches closer to the driver in the open position than with the jack-knife door

The electric operator is also the linear motion type with a ball-screw drive. It is connected to a lever off the front door. Mechanically operated switches control automatic stop positions as well as stepwell and warning lights.

## OUTWARD OPENING (AIR DOOR)

The air operator is a simple linear cylinder connected to a lever on each door and located inside the header cover. An interconnecting link between the doors controls their operation sequence. A safety release valve is located over the door and stepwell lights are operated by air pressure switches inside the header cover. Door operation by the driver is managed by a simple two-way manually operated valve, and air pressure holds the door either open or closed depending on the position of the valve. The operation speed is adjustable by use of flow control valves at cylinder inlet and outlet.

## JACKKNIFE DOOR - (If so equipped)

1. Loosen the roller bracket at the top of the rear door.
2. Adjust the length of rod (between the door control and the door) and the location of the rod end bracket on the door for proper open and closed position.
  - a. Lengthen the rod if the door opens too far and does not close against the top seal.
  - b. Shorten the rod if the door closes too hard and does not open far enough.
  - c. Move the rod end bracket forward if the door does not close against the seal and does not open far enough.
  - d. Move the rod end bracket rearward if the door opens and closes too far.
3. Attach the roller bracket to the rear door and adjust.
  - a. If the rear door hangs in the track when starting to close the door, move the bracket to the rear.
  - b. If the rear door does not open to the front enough, move the roller forward.

4. Perform the following adjustments and maintenance for ease of operation. The top of door should be approximately 3/8 inch below door header.
  - a. Move door upwards so that rubber door sweeps do not drag on stepwell treads. Adjust door height by loosening bolts and nuts that attach front door panel to front hinge. Holes in hinge are slotted. This permits vertical adjustment of door.
  - b. Assure that top edge of door nosing rubber does not drag on door stop header rubber. Remove the first three upper screws in the inner and outer nosing rubber retainer strips and force the nosing rubber downwards. Replace screws after the rubber nosing has been adjusted.
  - c. The rear upper corner of the rear door panel should not drag on rubber door stop on the header. To provide the required clearance, move the door roller bracket towards the rear of the bus. This effectively will move the door panel away from the door stop rubber.
  - d. Clean stepwell rubber treads and lower door rubber sweeps regularly. Cleaning these surfaces will reduce friction as the door is operated.
5. Assure that the door control rod end bracket is mounted squarely on door. If bracket is not square to the door, the yoke end pivot pin will bind. Adjust by loosening screws and tighten after bracket has been squared up.
6. Inspect the pivot nut on rod end bracket for burrs or other surface irregularities. Grind or file pivot nut so that its upper and lower surface is smooth.
7. Lubricate door hinge pin with a spray type lubricant (LPS No. 1). Lubricant should penetrate behind each hinge lug. Door hinge will operate quietly if properly lubricated.

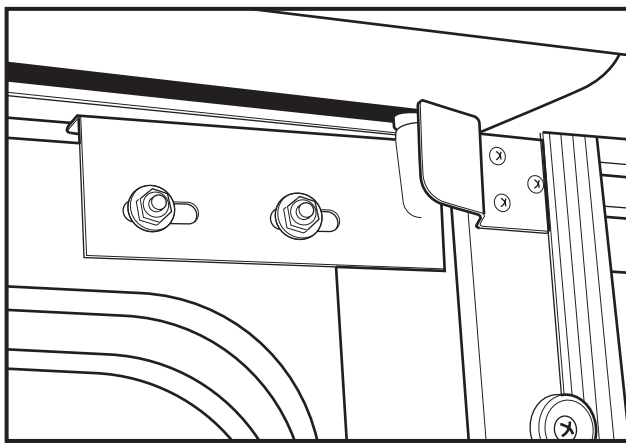

ROLLER BRACKET

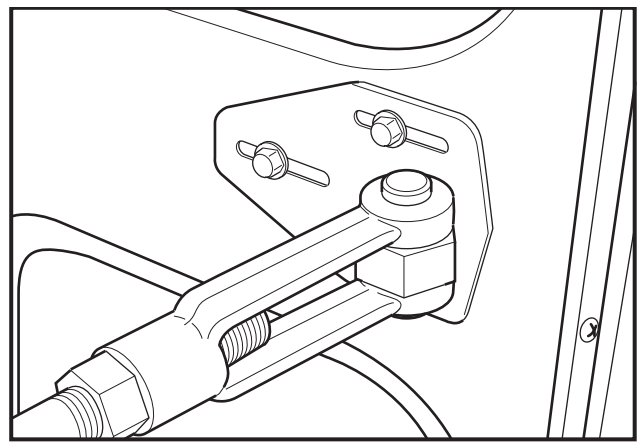

ROD END BRACKET

### **POWER JACKKNIFE DOOR**

**NOTE:** For air diagram, see drawing #0867606 supplied with vendor maintenance documents.

The following adjustments and lubrications should be performed on the power jackknife door (Options 0233, 0467 and 0468) to insure its proper operation.

1. Lubricate center hinge with LPS No. 1 type lubricant.
2. Adjust cylinder yoke so that when cylinder rod is fully extended in the open position, the door is not forced beyond its normal stopping point at the front stepwell band. Adjust cylinder mounting bracket adjustable yoke if required. **NOTE:** Improperly adjusted cylinder yoke can cause premature failure of door components.

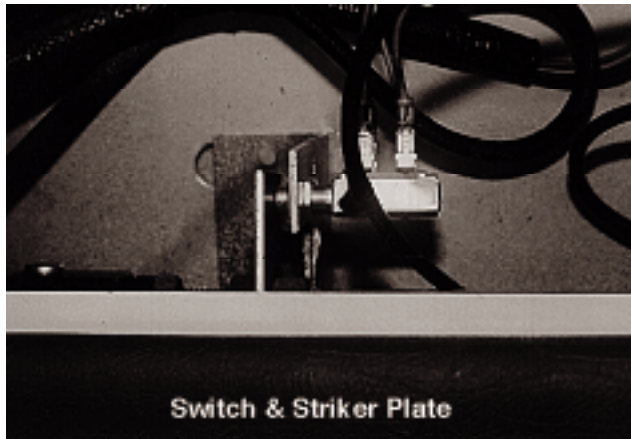

3. Adjust switch striker plate on cylinder rod so that it does not bind against the switch and switch bracket in the closed position.
4. Insure that the roller bracket is installed square on the rear door panel.
5. Insure that the center hinge barrel is not binding against the outer skin of the rear door panel.
6. Adjust opening and closing speed of the door at valves located on cylinder to insure smooth action. Air pressure should be at normal operating range (100-125 psi).
7. Upper pivot bracket retaining screw at lever assembly should be tightened to at least 20 ft. lbs.

Maintenance procedures for entrance doors are to be performed at intervals of 1 month or 1000 miles, whichever occurs first.

### ELECTRIC OUTWARD OPENING DOOR

The electrically operated outward opening door has a linear actuator that moves a lever attached to the front door. To open the door, hold the spring loaded switch in the driver's area in the "open" position until the door stops moving. An automatic switch stops the action of the door. To close the door move the switch to the "close" position and the door will stop automatically when fully closed. There is a keyed switch on the outside of the body on the cowl panel by the door that parallels the operation of the interior switch.

### **Emergency Release**

With the door in the fully closed position, pull the release lever in the header panel rearward as far as possible. You will feel the linkage release and then feel the lever snap into a "park" position so it will not return forward when released. Push the door open to exit the bus. To reengage the release mechanism, move the lever in the header back to its forward position, and hold the driver operated spring loaded switch in the "open" position until engagement is obvious or until door is in fully open position.

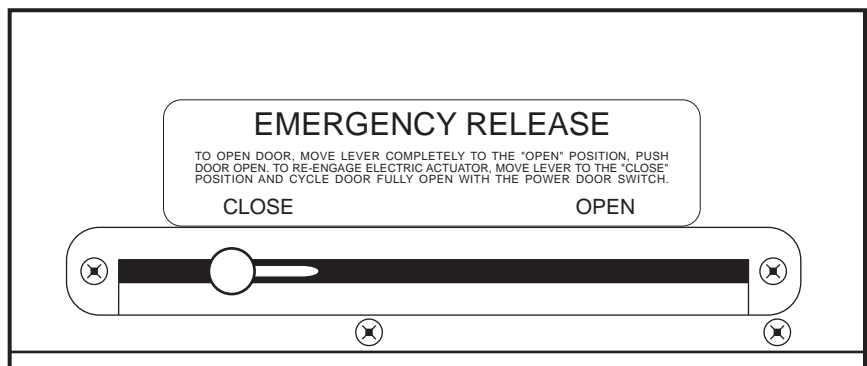

EMERGENCY RELEASE LOCATED IN HEADER ABOVE DOOR

## SECURITY LOCK (Outward Opening Door)

A key operated "bolt" slides into a hole in the header when the door is in the closed position and locked. This option also requires use of the hinged stop on the door control. If the lock becomes difficult to operate, remove access plate on the inner door panel and channel and lubricate with No. 2 lithium grease. (Access plate shown removed in illustration.)

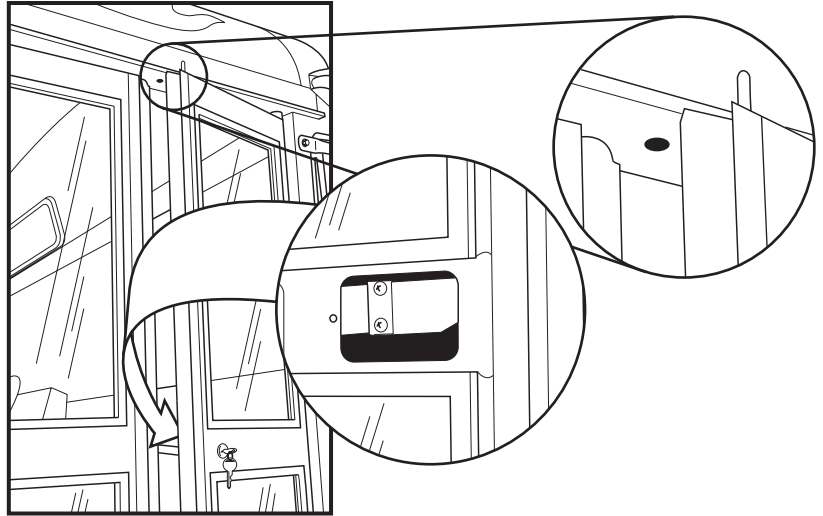

## VANDAL LOCKS

### ENTRANCE DOOR

To activate the optional electric entrance door vandal lock, pull the door to a full closed position from the outside of the vehicle. When this is done, the vandal lock is activated. To deactivate the lock insert key in lock located at right of the door (forward of door) and turn. Press against center section of door and it will open.

The manual vandal lock release handle is located in the lower kick panel of the entrance door. It rotates in a counterclockwise direction to latch. It can be locked in a latched position or in a 180 deg. unlatched position. The latch engages a bracket on the inside of the door. Before using the vandal lock, the hinged stop on the door control cover must be flipped down to keep the door control from traveling over center when closing the door.

Lubricate vandal lock every 6 months or 6000 miles, whichever occurs first. Use LPS-1 or "Apply"<sup>TM</sup> type lubricant and spray into the bushing and shaft in the center at the base of the lock handle. Also spray lubricant into key lock mechanism. Rotate the lock handle to insure smooth operation.

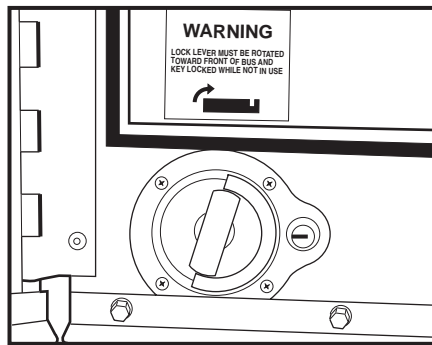

MANUAL - EXTERIOR

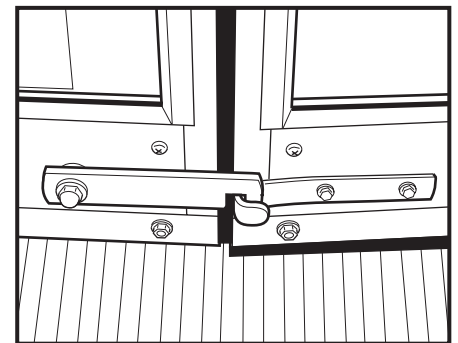

MANUAL - INTERIOR

### EMERGENCY DOOR

The emergency door and rear emergency window vandal lock has a lock cylinder which is placed in the lock to make the emergency door inoperable. When the cylinder is in place in the lock, the coach cannot be started. To complete the ignition circuit, the lock cylinder must be removed from the lock and placed in the receptacle at the side of the door. When this is done, the circuit is completed and the coach can then be started.

No lubrication is required with this system.

### SLIDING BOLT VANDAL LOCK

The sliding bolt vandal lock, for the emergency door and rear emergency window is an interior latch that prevents the door from being opened from the outside when engaged. The bolt is connected to an interlock assembly which prevents engine starting when the door is locked. If the lock is activated after the engine is running, an audible alarm is sounded in the driver's area.

Lubricate sliding bolt mechanism every 6 months or 6000 miles, whichever occurs first with LPS-1 spray lubricant.

# **KEEPING YOUR VEHICLE LOOKING NEW**

---

## **WASHING YOUR VEHICLE**

The best way to preserve your vehicle's finish is to keep it clean by frequent washings. Wash the vehicle in lukewarm or cold water. Do not use hot water or wash in the direct rays of the sun. Do not use strong soap or chemical detergents. All cleaning agents should be promptly flushed from the surface and not allowed to dry on the finish.

**CAUTION: Pressure washing may cause damage to finish. Pre-test pressure washer on similar surface prior to applying pressure and chemicals to your vehicle. Pressure washers using recirculated water should filter the water to remove abrasive grit.**

## **POLISHING AND WAXING YOUR VEHICLE**

Polishing with nonabrasive wax is recommended to remove accumulated residue and eliminate any "weathered" appearance.

## **FOREIGN MATERIAL DEPOSITS**

Calcium chloride and other salts, ice-melting agents, road oil and tar, tree sap, bird droppings, chemicals from industrial chimneys and other foreign matter may damage vehicle finishes if allowed to remain on painted surfaces. Prompt washing may not completely remove all of these deposits. Additional cleaners may be needed. When using chemical cleaners developed for this purpose, be certain they are safe for use on painted surfaces.

## **FINISH DAMAGE**

Any stone chips, fractures or deep scratches in the finish should be repaired promptly. Exposed metal will corrode quickly and may develop into a major repair expense.

## **FLOORS AND FLOORCOVERING**

It is imperative that the interior of the bus be kept clean and floorcovering is an important part of this maintenance. Regular cleaning and care will prolong the life of floorcovering and improve the general appearance.

Floorcoverings should be swept daily and mopped weekly with a mild detergent and water. Do not use floor sweeping compounds. Be sure that dirt, pencils, paper etc. that may cause the emergency door to improperly seal are removed. Do not use harsh detergents and excessive amounts of water. Do not use a water hose to wash out the bus, deterioration and damage to the wood floor could occur.

**WARNING: Petroleum products, such as oil and grease, quickly deteriorate the floorcovering. These type products should be removed, as soon as possible.**

Continuous care must be exercised in the step well area where foreign objects can create a safety hazard. Soil and debris cannot be permitted to build up as this not only creates a hazard for passengers but hinders door operation and door sweeps. Insure that screws for floor trims and aisle trims are seated tightly, so as not to loosen and create a safety hazard.

# **ENGINE ACCESS**

---

1. Pull out on top portion of release latch to disengage latch mechanism.
2. To open hood, lift handle. The hood is designed with a built in prop. When hood is opened to it's maximum and lowered, the prop locks in the open position.

**NOTE:** A hole is provided in the prop as a safety device. When the hood is in the opened position a pin should be placed in the hole to prevent inadvertent unlatching of the prop.

3. To close the hood, remove the pin and lift as to open further, this disengages the lock and allows the hood to close.

### HOOD REMOVAL FOR MECHANIC'S ACCESS

1. Pull out on top portion of release latch to disengage latch mechanism and open hood completely.
2. Using a 1/2-inch socket wrench remove the two (2) flange nuts securing the prop bracket to the hood. Hold the hood up and allow prop to rest next to engine.
3. Let the hood down, then using two (2) 7/16-inch wrenches, remove hinge pins from hinges located on top side of hood. This will allow hood to be completely removed.
4. To replace hood, reverse this procedure.

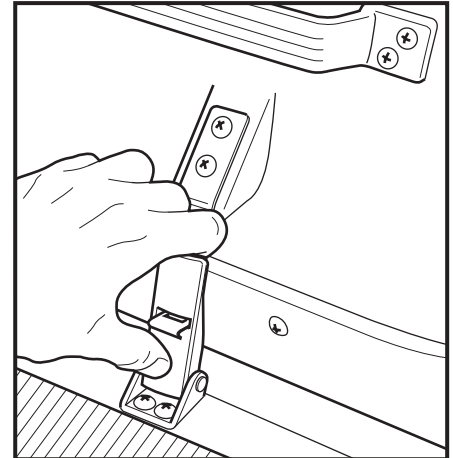

## HEATERS

### GENERAL INFORMATION

Blue Bird heaters are hot water type which depend on heat generated by the engine for their function. Heat from the engine is picked up by the engine coolant which is pumped through the heaters inside the body and back into the engine. A typical heater inside the body is made of a heat exchanger coil and fans which move air across the coil. Air moving across the coil picks up heat from the engine coolant and transfers it into the body.

Satisfactory performance of the body heaters is basically dependent upon:

1. Adequate engine (coolant) temperature - this can be altered by thermostat rating (which should never be higher than recommended by the engine manufacturer) and/or shutters.
2. Adequate coolant flow - this varies with engine speed and can be increased if necessary by the use of an auxiliary water pump. The heaters are rated at six gallons per minute.
3. Proper fan operation - all motors have multiple speeds, and can most easily be checked for function by operating the motor switches individually and listening for the speed variations.

Many other factors affect performance, but the three mentioned are most basic.

### HEATER OPERATION

Be sure the engine radiator is full and all coolant flow valves are open. See charts on valve location. **Do not leave the engine running while opening or closing valves.** Warm up the engine to operating temperature with the engine at up to 1800 RPM, if possible, and turn on the heater fans and the auxiliary water pump if so equipped.

Under extremely cold weather conditions, turning on the heater fans will cause the engine temperature to drop noticeably as heat from the engine is being transferred into the body. But as air temperature inside the body rises, engine temperature also rises. More heat will also be generated by the engine when it is caused to work in moving the vehicle. This is especially noticeable with diesels which do not warm up at idle as readily as gasoline engines. The fan speeds and subsequent air volumes can be controlled at the discretion of the driver for defrosting and ultimate passenger comfort.

## CONTROL PANEL

The heater control panel is located on the rear surface of the dash to the right of the instruments. The indicated switches and levers control the motors and air outlets as shown.

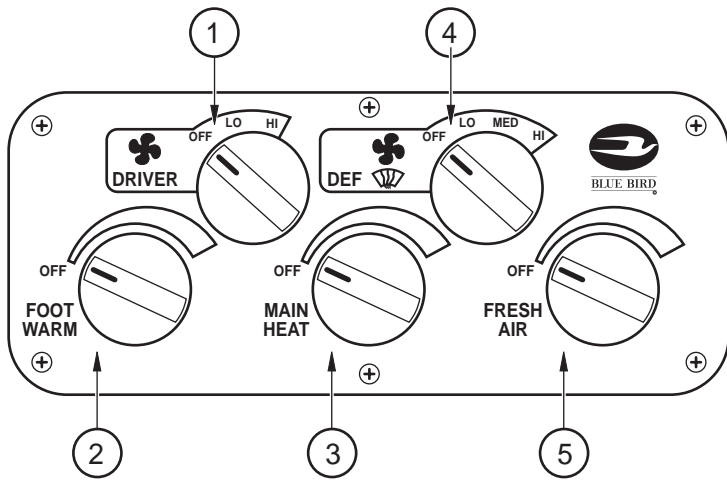

## OUTLET LOCATIONS

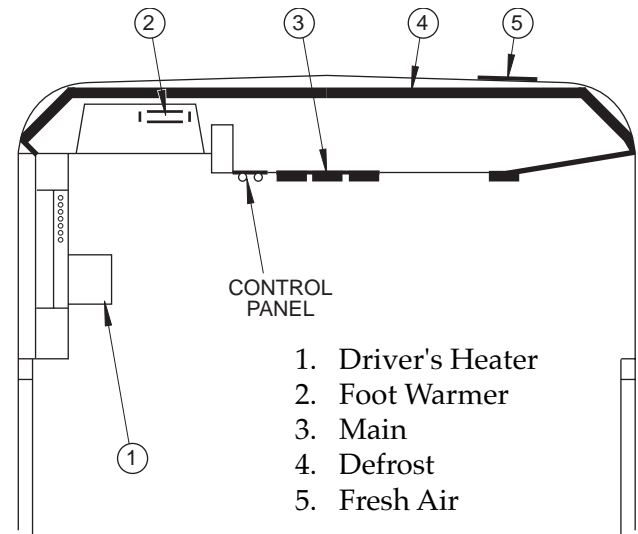

The heater is located in the right front corner forward of the entrance door and an auxiliary unit is located under the driver's seat. As indicated, the electrical switches and mechanical operators control the volumes and directions of air being moved. The main heater has a three-speed control switch for manual low or high speed operation and an additional maximum output position for flash defrosting or the most extreme of conditions. All the air from the main heater blower can be used for defrosting by leaving the main outlet and foot warmer outlet closed.

## HEATER ACCESS

The front heater can be accessed from two different places. From the outside, RH side of the front of the bus, and from the inside of the bus on the dash near the stepwell.

**NOTE:** To gain access from the front, see: FRONT ACCESS .

To gain access to the heater core and filter from the interior of bus, remove the interior heater access panel shown.

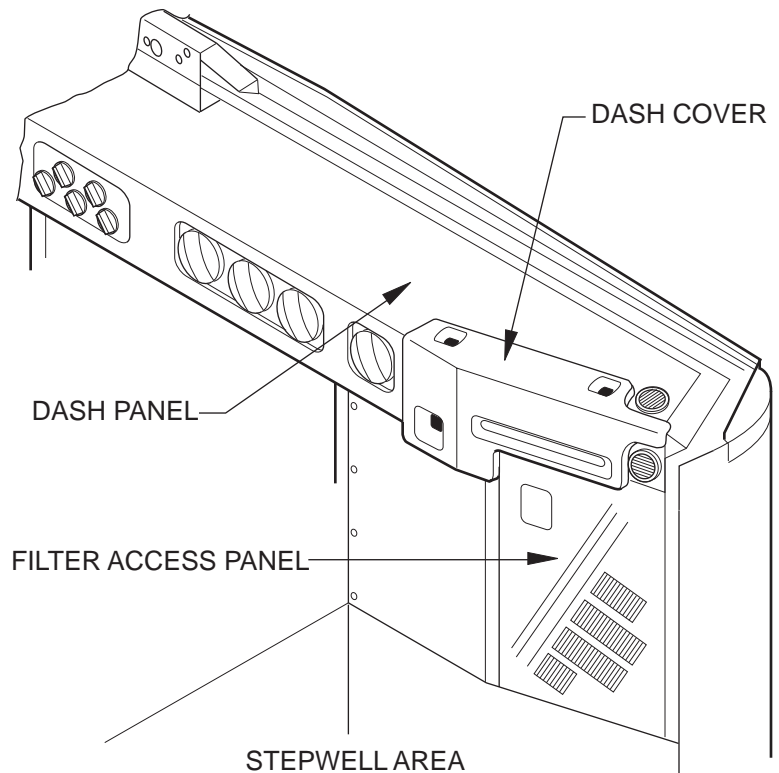

## FILTER

The main heater coil is protected by an air filter. The purpose of the filter is to prevent dirt and dust from collecting on the heat exchange surfaces and lowering the efficiency of the heater. The filter can be cleaned or replaced by removing the filter access panel. The service frequency of the filter will depend entirely upon the operating conditions of the bus and care should be taken to keep it cleaned. A dirty filter is restrictive to air flow and reduces maximum heater output.

## DEFROSTING

Windshield fogging and frosting is caused by warm, humid air coming in contact with a cold windshield, which causes the moisture in the air to condense and possibly freeze if the windshield is cold enough. The warmer the windshield, the less moisture will condense on it. During initial warm-up, the defroster blowers should be operated at low speed to preheat the inside of the windshield glass. If the defroster is not turned on until the condensation starts, it is more difficult to heat the glass and overcome condensation. As passengers are loaded onto the bus, the moisture content of the air inside the bus increases. This moisture content tends to be lowered by opening the heater fresh air inlet. The most difficult defrosting conditions will be encountered when there is a large passenger load which must remain on the bus for extended periods of time, such as on a charter or over-the-road activity trip. Each passenger continually adds to the moisture content of the air, and after a period of time, the humidity can become quite high.

This condition can be improved by slightly opening the forward driver's window, allowing the moist air to escape into the low pressure area outside the bus at that location.

## CARE AND CLEANING OF DEFROSTER FANS

Defroster fan motor bearings are lifetime lubricated and do not require maintenance. Occasional cleaning of the blade and guard with a soft bristle brush and a vacuum cleaner or compressed air will help to maintain efficiency. As with any other fan, if the blade is damaged or imbalanced, vibrational damage can occur to the motor or surrounding components, so the blade should be replaced immediately.

**WARNING: Do not operate a defroster fan without the fan guard properly installed.**

### **Procedure:**

1. Remove front half of fan guard by gently separating plastic tabs with a screwdriver or other hard instrument. Be careful not to damage tabs, as these connect the front half of the fan guard to the rear half. Removing the guard will provide access to the fan should it need to be replaced.
2. To remove the fan blade, use a 3/32" Allen wrench in the set screw located directly behind the fan. This should loosen the fan blade for removal.
3. The rear half of the fan guard can also be removed if necessary. After removing the fan, remove the two nuts and washers on either side of the center point and lift guard off.

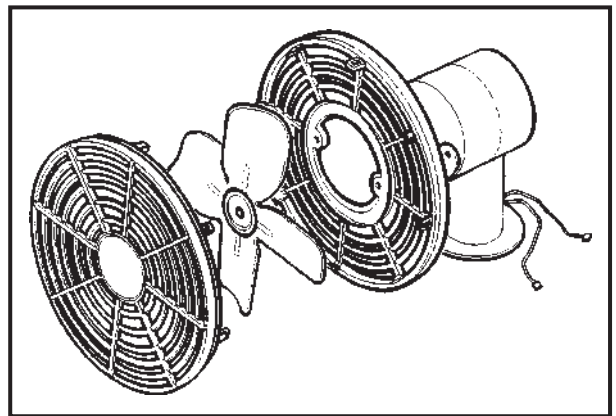



## HEATER DEFROSTER LOCATION

The blower in the front main heater contributes to keeping the driver's area glass clear of fog and frost. See OUTLET LOCATION diagram. Defrosting performance is enhanced greatly by the use of fresh air into the heater. Open front access panel and observe fresh air intake on driver's side of bus to verify the proper functioning of the fresh air intake.

Satisfactory performance of the body heaters is basically dependent upon:

1. Adequate engine (coolant) temperature - this can be altered by thermostat rating, which should never be higher than recommended by the engine manufacturer and/or shutters.
2. Adequate coolant flow - this varies with engine speed and can be increased if necessary by the use of an auxiliary water pump. The heaters are rated at six gallons per minute.
3. Proper fan operation - the three speed motor can most easily be checked for function by operating the motor switch and listening for the speed variations.

Many other factors affect performance, but the three mentioned are most basic.

## DEFROSTER FAN LOCATIONS

Opt. 0525 - On the TC with deluxe door control and standard manual control, the fan is mounted on the door control bracket. With power door controls, the fan is mounted on the dash cover.

Opt. 0530 - One fan is installed per conditions outlined in Option 0525 for the lefthand fan. The other fan is mounted on the dash cover.

Opt. 0532 - Fan is located on the upper inner panel in the center.

Opt. 0535 - Fan is located on the upper inner panel 6" to the left of center.

Opt. 0541 - Defroster fan is located on the dash cover.

## DRIVER/PASSENGER COMFORT

When defrosting requirements have been satisfied, the other openings can be set as necessary for comfort. The adjustable outlets on the rear surface of the dash can be directed toward the driver and/or passengers as desired. The auxiliary unit under the driver's seat has a two-speed electrical switch and it directs air upward for the driver's left side and forward around the steering column area.

## HEATER BLEEDING INSTRUCTIONS

Use of antifreeze (ethylene glycol type only) is recommended for summer or winter operation because of its corrosion inhibition and lubrication properties. A 50-50 solution of antifreeze and water is preferred and it gives freeze protection to about 30 degrees F below zero. Ultimate protection is attained at 68% antifreeze (about 92 degrees F below zero); a higher concentration of antifreeze should never be used.

If it becomes necessary to completely refill the chassis coolant system, the following procedure must be followed to insure adequate heater bleeding. During the bleeding process, it will be necessary to remove the radiator cap and refill cooling system several times to insure adequate coolant is available to replace purged air and coolant lost when bleeding.

**WARNING: Extreme care must be used when removing radiator cap. As coolant becomes hot, pressure is built up in the cooling system. Rapid venting and/or removal of radiator cap will cause coolant to boil up and spray out and can result in serious burns. Slowly vent off pressure before removing radiator cap.**

## INITIAL FILL WITH GRAVITY HOSE WITH ENGINE OFF AND COOL

1. Open heater supply valve at rear of engine block and close heater return valve at the transmission oil cooler.
2. Open 1/4 inch vent line valve located above radiator and direct vent line flow back into the radiator fill neck.
3. Fill radiator with engine coolant until full and close heater supply valve.
4. Start engine and run at high idle (1500 RPM). Refill radiator if coolant level drops. Open heater supply valve on rear of engine block. Allow coolant to flow through vent line back into top of radiator. It is very important to verify this coolant flow. Do not run engine longer than 50 seconds unless a flow of coolant is evident at vent line.

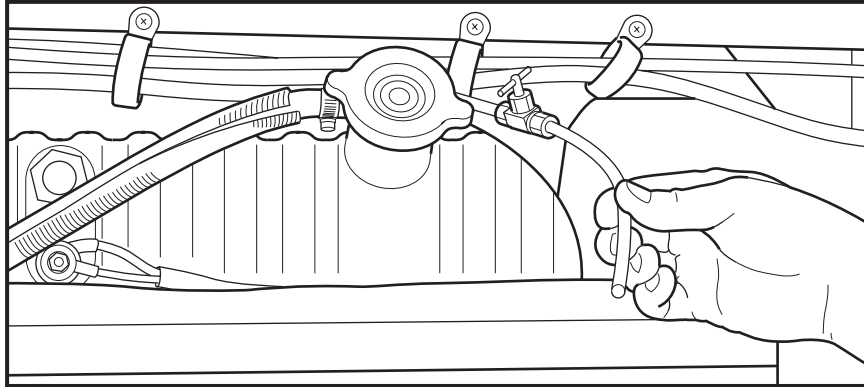

5. After solid stream of coolant (no bubbles) is evident at vent line discharge, close vent line valve. Refill radiator and install radiator cap. Check for leaks. Open heater return valve.
6. Shut off engine. Fill coolant recovery bottle to 1 inch above cold fill mark. (Level of coolant in bottle will only stabilize after several heating and cooling cycles.)

**CAUTION: Failure to properly bleed all the air out of the engine and heater circuit could result in the loss of an engine.**

**WARNING: Never idle engine in closed areas. Never sit in a parked or stopped vehicle for any extended amount of time with the engine running; exhaust gases, particularly carbon monoxide, may build up. These gases are harmful and potentially lethal. Carbon monoxide is colorless and odorless, but can be present with all other exhaust fumes. Therefore, if you ever smell exhaust fumes of any kind inside your vehicle, have it inspected immediately by your dealer and have the condition corrected. Do not drive with exhaust fumes present.**

## PREVENTIVE MAINTENANCE - to be performed annually

### Hoses

Check all water hoses for kinks that can prevent water flow or chafing that can cause failure. Look and feel for hardening of rubber or cracks that result from aging. Hoses should be replaced when external cover tube cracks first appear. Hoses exposed under floor and in the engine area will deteriorate faster than those inside the body due to their exposure to the elements. Therefore, these hoses need to be checked more frequently.

## Coils

The heater will be most efficient when the coil and fins and air flow passages are kept clean and free from dust and dirt. The coil should be cleaned carefully with compressed dry air or vacuum, and a soft bristle brush. Damaged fins should be straightened with a fin comb to prevent air flow restrictions. The heater coil can be accessed through the right front inside access panel, or, for underseat heaters, removal of passenger seat cushions.

## Motors, Switches, Blowers and Fans

Motors are essentially maintenance free and do not require lubrication or cleaning, but excessive vibration caused by damaged blower wheels or fans can cause motor damage. Check wheels and fans for obstructions or damage by running each fan alone, then listening and feeling for irregularity. Replace damaged wheels or fans to prevent vibratory damage to surrounding and supportive housing parts and fasteners as well as motors.

Switches are also maintenance free, but loose wiring connections to switches or motors can cause excessive resistance and overheating damage. Wires to switches can be checked or repaired by removal of the switch mounting panel next to the driver.

## Panels and Housings

Fasteners which connect and retain structural and access panels should be checked and tightened as necessary. A loose screw can allow panel vibration, resulting in excessive noise, additional fastener failure, or metal fatigue cracks.

## HOSE REPAIR

Hoses are installed with as few joints as possible so as to prevent the possibility of leaking joints. If a portion of hose becomes damaged, a new piece of hose can be spliced in by use of 4 inch brass tube (Blue Bird part #1701903), and hose clamps. If hose must be replaced due to aging, the entire length of hose should be replaced. Air duct hose can be repaired with a good brand of wide PVC tape or duct tape.

## REMOVAL OF UNDERSEAT FAN AND MOTOR ASSEMBLY

1. Remove screws securing outlet to heater, front and rear.
2. Lower outlet panel and move it toward aisle to clear end of heater.
3. Rotate outlet panel toward rear, away from heater, exposing fan and motor assemblies. Remove screws securing fan and motor to heater for service.

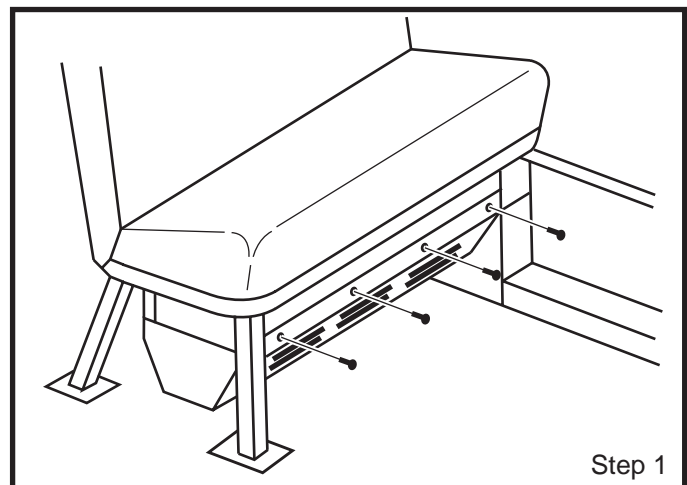

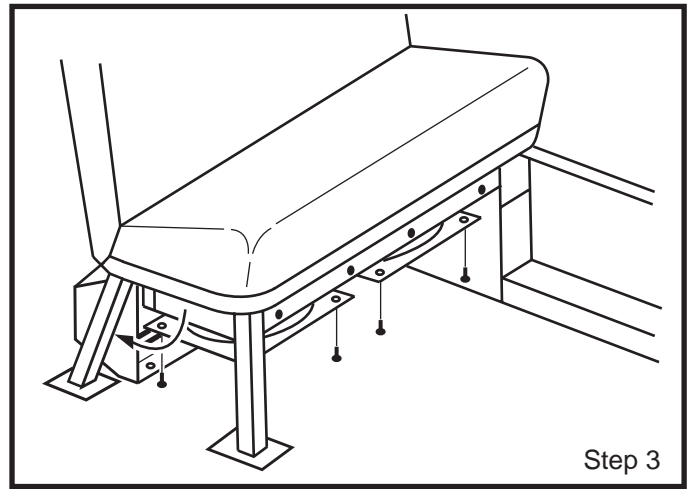
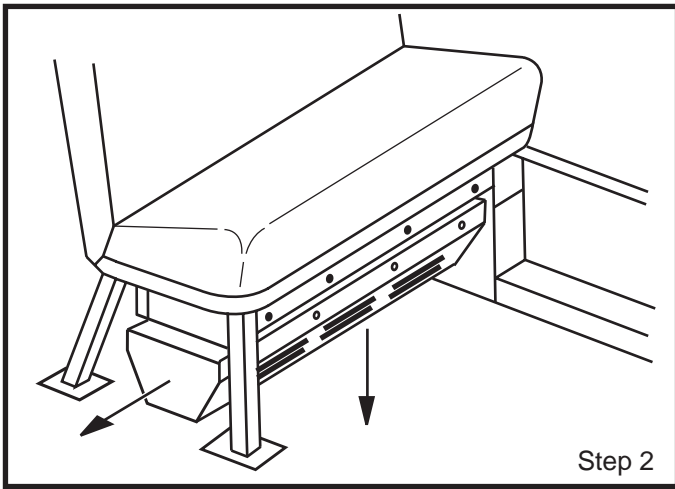

**STANDARD HEATER CUT OFF VALVE LOCATION**

Valves No. 1 & 2 are used to isolate the heater system from the engine in case a leak occurs within the system while bus operation must be continued, or for repair to a system.

**ENGINE:** Cummins 5.9TA

Valve No.	Location
1	Rear LH Corner of Engine Block
2	At Transmission Oil Cooler

————— PRESSURE LINES

- - - - - RETURN LINES

① VALVES

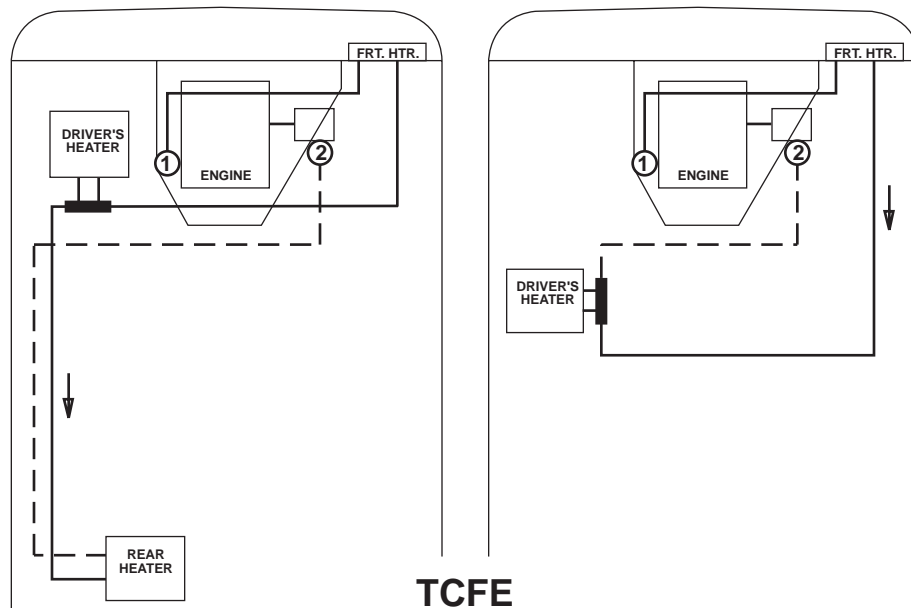

## HEATER HOSE CLAMP SERVICE

Tighten heater hose clamps after first 1,000 miles and annually thereafter. Heater hose clamps are located at the underseat heater coil, behind the access door in the heater hose covering immediately forward of the left front wheelhousing, and under the floor near the right front and driver's heater. The part number for this clamp is 1056050. Torque clamps to 45 inch lbs. new and 34 inch lbs. for retorque. NOTE: High-miler hose requires lined hose clamps, silicone hose requires constant torque clamps.

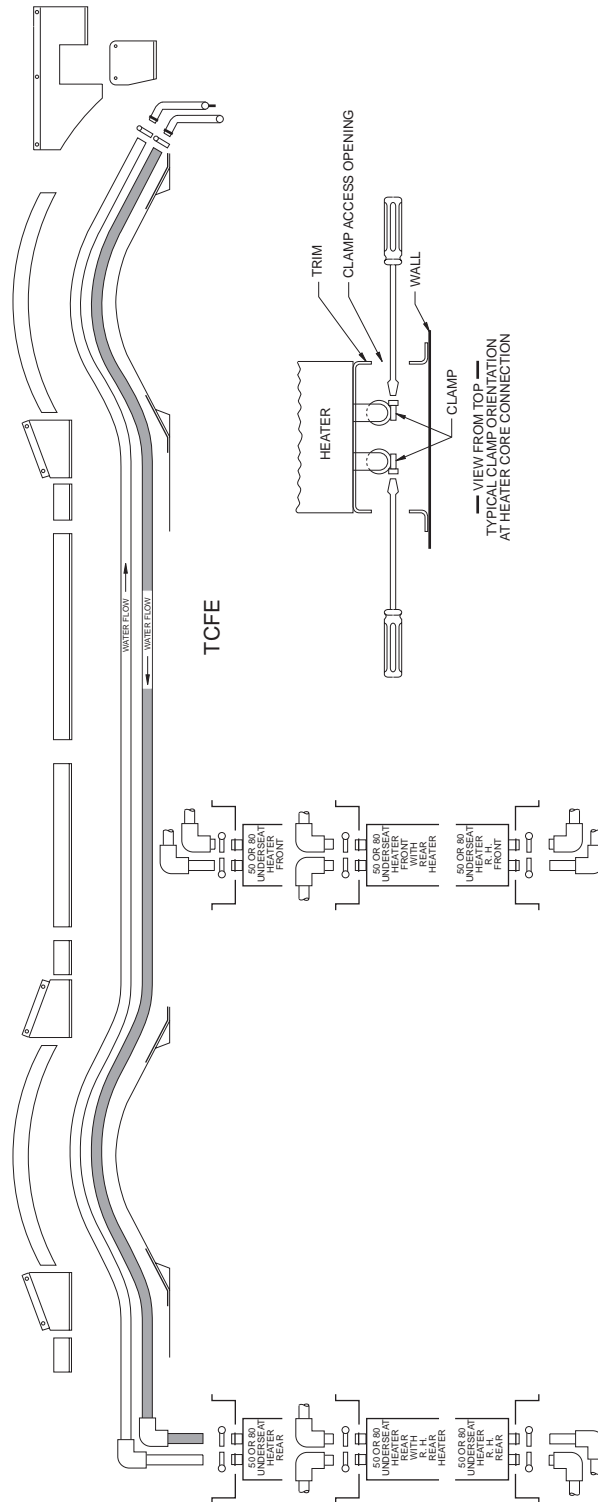

## HEATER & HEATER CONNECTIONS WATER CAPACITY CHART

**Note:** Water capacity of heaters includes tubing within heater enclosure.

Option No.	Description	Capacity (Quarts)
Std	90TC Front Heater	3.19
Std	12 Driver's Heater	.25
1325	50 Front Underseat Heater	1.56
1330	50 Rear Underseat Heater	1.56
1332	50 Rear RH Underseat Heater	1.56
1336	80 Front Underseat Heater	2.34
1342	80 Rear Underseat Heater	2.34
	1 Foot of Connecting Line	.17

### **Example:**

Unit with 5.9TA Cummins Engine & Options 1325 & 1342

Driver's Heater (Std)	.25
Front Heater (Std)	3.19
50 Front Underseat (Opt 1325)	1.56
80 Rear Underseat (Opt 1342)	2.34
76 Ft. of Heater Pipe with 0.17 quarts per foot	<u>12.92</u>
	20.26 in Heating System
Capacity of engine coolant system	<u>24.60 qts. in Engine</u>
	44.86 qts. Total Cap. (11.22 Gal)

## ENGINE BLOCK HEATER(S)

The engine block heater(s) are designed to help maintain a warm engine block for easier starting and faster warm up.

If the bus will be stopped longer than one hour in cold weather conditions (below freezing), plug in 120 volt cord to outlet located as shown in illustrations. Be sure to unplug heater and properly stow the cord before moving the bus.

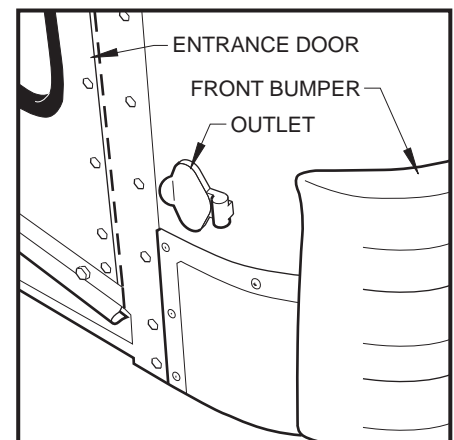

TCFE

# WINDOWS AND WINDSHIELDS

## WINDSHIELD GLASS REPLACEMENT

The windshield is four-piece flat.

1. Remove vertical filler strip in glazing rubber on each side of broken glass; remove horizontal filler strip in glazing rubber on top and bottom of broken glass. It will be necessary to cut the horizontal filler strip after it is pulled past the glass.
2. Starting at a corner, push glass free of glazing rubber from inside of bus outward and remove.
3. Position new glass in glazing rubber.
4. Using installation tool, work glass into glazing rubber.
5. Seal glass to glazing rubber from outside of the bus with an adhesive sealant such as, Silastic 732 RTV Adhesive/Sealant.
6. Apply soapy solution to filler strip channel on glazing rubber to act as a lubricant for easier installation of filler strip.
7. Using filler strip tool, insert fillet strip into channel on glazing rubber.



Step 4



Step 7

## SPLIT SASH WINDOW & GLASS REPLACEMENT

**NOTE:** The glass used in our bus meets FMVSS 205 and 217. Therefore, when a glass is broken, it should be replaced with identical glass.

1. Remove four screws securing window frame to bow.
2. Pull window to inside of body and remove.
3. Remove 6 screws (3 on each side of window) holding assembly together.



Step 1



Step 2



Step 3



Step 4

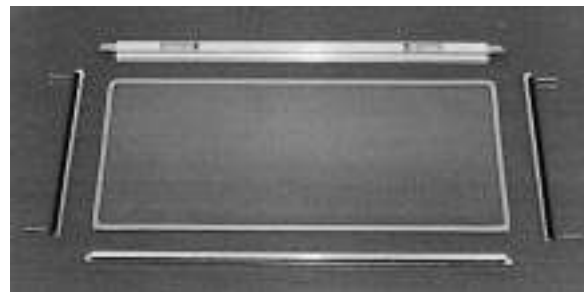

Step 5

4. On bottom glass, simply pull aluminum channel off top and bottom of glass.
5. To remove glass from top part of window, remove 6 screws holding frame around glass.
6. Reassemble window by reversing above procedure.
7. Apply weather seal caulking around window frame to prevent leaking.



Disassembled Window

**WARNING: When replacing broken or damaged glass, use extreme care at all times to prevent personal injury. This includes the use of proper replacement parts, tools and personal protective equipment, such as gloves and safety goggles.**

### WINDOW LATCH REPLACEMENT

1. Remove screw and block located in side channel directly above stationary glass.
2. Lower sliding sash so that latch enters large notch covered by block removed in Step 1.
3. With latch in large notch, push finger holds outward until inside edge is exposed. Pull latch out of finger hole opening.
4. Finger latch is pried off attached metal latch with any tool that provides leverage. Latch may now be removed and replaced.
5. Reassemble by reversing procedure.

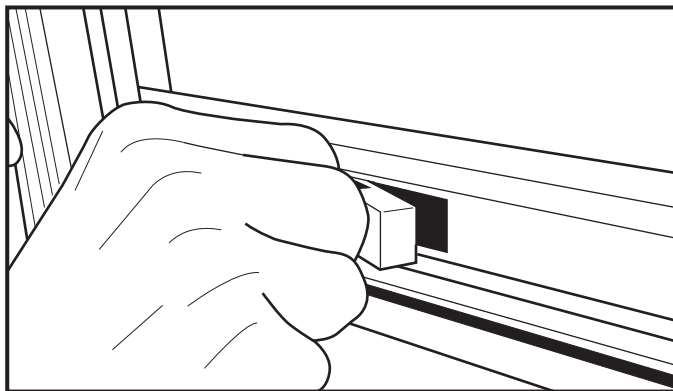

Step 3

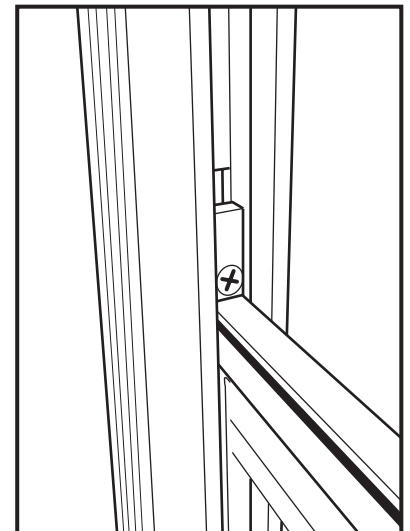

Step 1

**NOTE:** Lubricate latches and sliding seal of top window with silicone spray every 30 days. See decal on driver's window.

### ENTRANCE DOOR GLASS REPLACEMENT

1. Apply pressure against glass from the outside of the bus, starting at a corner and push glass and glazing rubber off of metal flange.
2. Remove glazing rubber from around glass.
3. Put glazing rubber on new glass.
4. Wrap a cord around the glazing rubber and rest the glass on the bottom flange of the opening from outside the bus.
5. Pull cord slowly and work glazing rubber onto metal flange.
6. Apply pressure to glass from inside of bus to assure proper seal.

**WARNING: When replacing broken or damaged glass, use extreme care at all times to prevent personal injury. This includes the use of proper replacement parts, tools and personal protective equipment, such as gloves and safety goggles.**



## REAR VISION GLASS REPLACEMENT

1. Remove filler strip from channel in glazing rubber.
2. Apply pressure against glass from the outside of the bus starting at a corner and push glass and glazing rubber off of metal flange.
3. Remove glazing rubber from glass.
4. Put glazing rubber on new glass.
5. Apply a soapy solution to the flange on the bus body and to the filler strip channel on glazing rubber. This acts as a lubricant for easier installation. Wrap a cord around the glazing rubber and rest glass on bottom window flange from the inside of the bus body.
6. Apply pressure from the inside of the bus body to insure glass is seated properly. Pull cord slowly and work glazing rubber onto the window flange.
7. Using filler strip tool, insert filler strip into channel on glazing rubber. (Filler strip tool is available from your distributor.)
8. Apply clear caulking around glass and window flange on the outside of bus body to insure that no leaks occur.

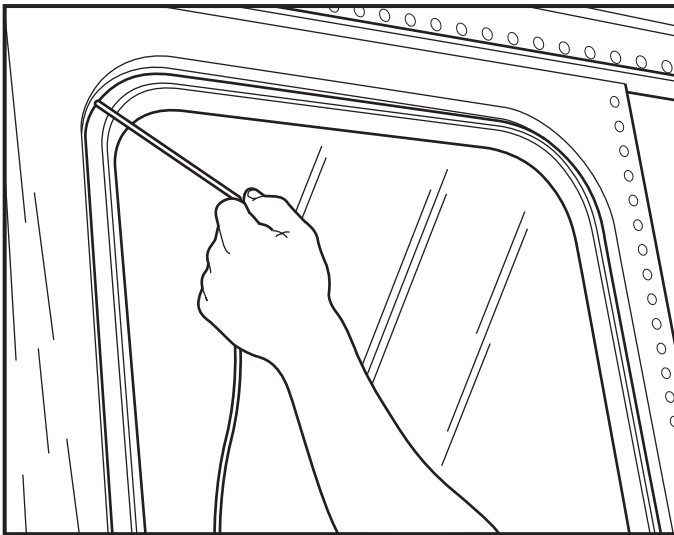

Step 6

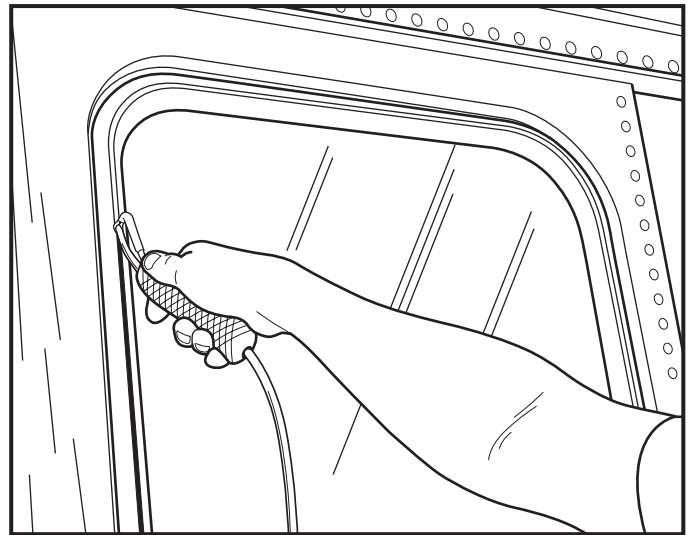

Step 7

## TRANSIT SLIDING WINDOW MAINTENANCE

1. Remove screws in outside aluminum extrusion.  
**NOTE:** On push-out windows, when hinge screws are removed and interior latch released, window sash may be removed from frame.
2. Use putty knife to loosen sealer between window frame.
3. After sealer is loosened around entire perimeter of window frame, gently pry out using screwdriver.
4. Reverse procedure for installation.

**CAUTION: DO NOT pry window frame from body without loosening sealer. Unless sealer is loosened, window frame will be bent.**

## Glass Replacement Procedure

1. To remove push-out transit sliding window, release window lever (1) located inside the bus at the bottom of each push-out window. Remove hinge screws (2) on outside of body. Lift and pull window out of section. To remove stationary transit sliding window, remove all screws (3) between inner frame (4) and outer frame (5). Lift and pull window out of section.
2. Remove four screws and take out vertical brace (6) located in the center of the window.
3. Remove two window stops (one on each side at top of window). Slide glass to the center of the window. Spread apart the inner frame (4) just enough to lift glass frame (7) out.
4. To remove glass from frame, slide rubber seal (8) out of vertical rail (9) exposing two screws. Window glass is removable after screws are removed.
5. Remove glass.
6. To replace glass, slip glazing vinyl seal around glass and slide into frame.
7. Reassemble by reversing procedure.

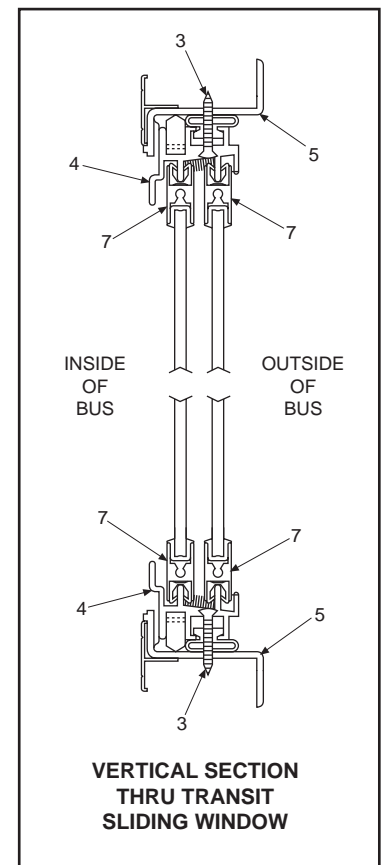
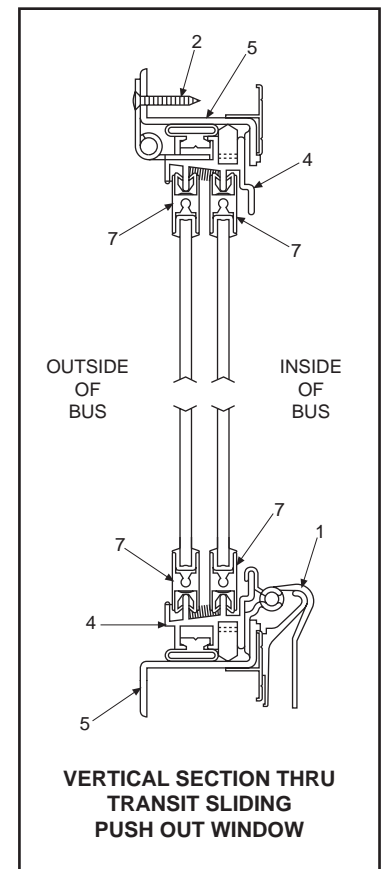
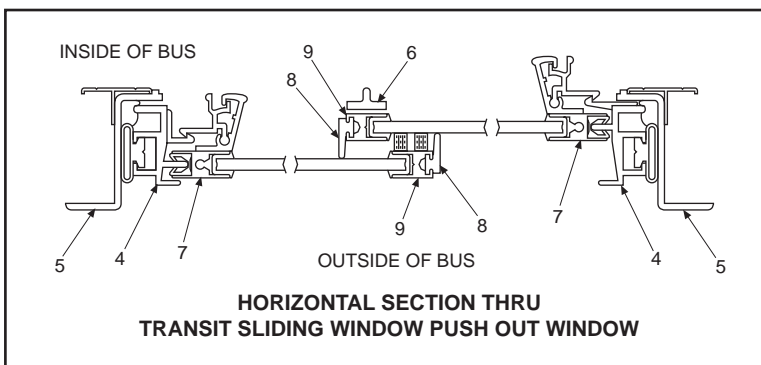
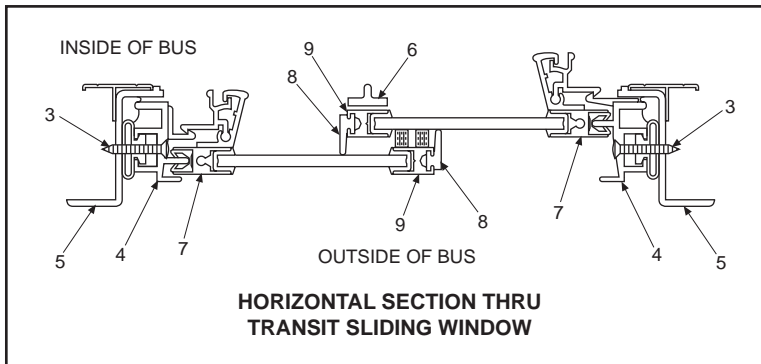

**WARNING: When replacing broken or damaged glass, use extreme care at all times to prevent personal injury. This includes the use of proper replacement parts, tools and personal protective equipment, such as gloves and safety goggles.**

# WINDSHIELD WIPERS

## WIPER ARM REMOVAL & INSTALLATION

To replace the wiper arm assembly if damaged, follow the procedure outlined below.

**NOTE:** Before removing any wiper arm, it is first necessary to operate the wipers briefly, stopping the blades in the normal park position.

First install a .1 pin in hole located on wiper arm above the rubber boot in order to keep spring in stationary position during reinstallation. Remove the cap nuts, which secure the wiper arm and idler arm to the wiper and idler shaft, respectively. Remove the wiper arm and place new arm (Blue Bird No. 0348177) over wiper shaft and make sure the new arm is replaced in the same position as the old arm was removed. Place original cap nuts on shafts and tighten.

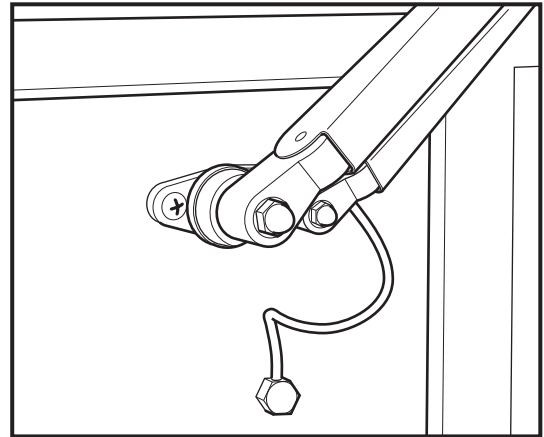

## WASHER SOLUTION RESERVOIR

Periodically check the windshield washer solution reservoir, located behind the front access panel on the driver's side. Be sure there is an adequate supply of fluid at all times. The solution used is a 50-50 mixture of methanol alcohol and water.

## WIPER ASSEMBLY REPLACEMENT

To replace wiper assembly (Blue Bird No. 0348144), loosen lock nut, remove screw and pull wiper assembly loose from wiper arm. Replace the wiper assembly and use original screw and lock nut. Tighten lock nut securely, but do not tighten enough to compress the saddle. Blade must be free to move on axis (machine screw) and within the saddle. Threading the lock nut until flush with machine screw end will give a secure and serviceable installation.

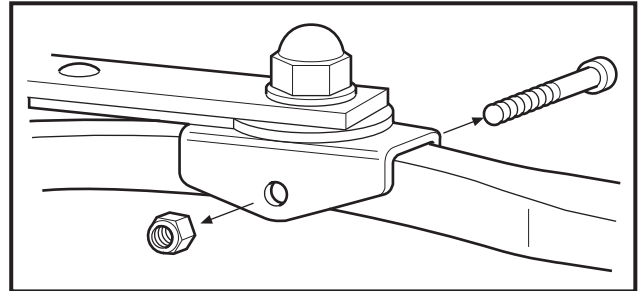

## WIPER REFILL REPLACEMENT

To remove wiper refills, follow the procedure outlined below.

1. Lift end clip with screwdriver as shown in. This releases locking indentations (A) and allows end clip retainers (B), to be removed through blade claw.
2. Repeat procedure to remove retainer clip on opposite end of wiper.
3. New end clips are provided with replacement Anco refills. To install, remove one clip and slide the refill through all claws until end clip locks into place.
4. Install second end clip, snap-locking devices A and B into place to secure refill.

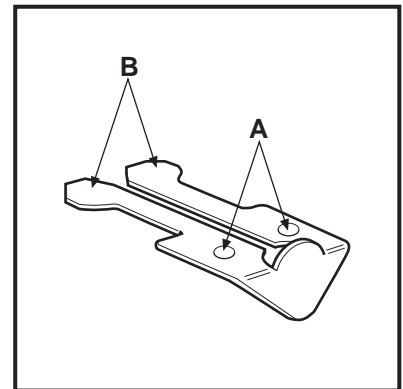
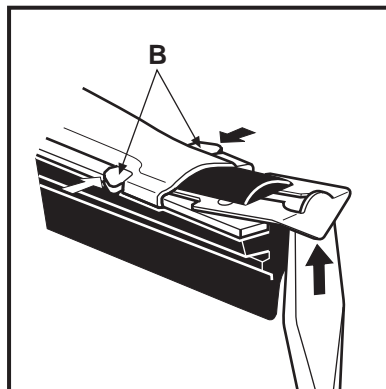

## LOWER SIDE PANEL REPAIR PROCEDURE

1. Remove the lower portion of the side panel by carefully drilling out the vertical rows of rivets on each side of the panel from the bottom of the floor line rub rail to the bottom of the skirt and the rivets attaching the bottom rub rail to the panel to be removed. Cut the panel not less than one inch below the floor line rub rail and remove.
2. Clean to bare metal the one-inch wide section of panel left below the floor line rub rail and apply a one-inch wide bead of Amicon two-component epoxy, TX-4009 or equivalent, following directions and recommendations of the adhesive manufacturer.
3. Insert the replacement panel between the rub rail and the original side panel far enough to insure a minimum of 1/2 inch of the replacement panel is under the rub rail. Install Cherry SSPV 86 blind rivets, Blue Bird P/N 0888222 on 3 1/2 inch centers through the rub rail lower flange and the new and old side panel.
4. Replace the vertical rows of rivets and the rivets attaching the bottom rub rail with the same type, size, and quantity of fasteners as was used in the original construction or with Cherry SSPV 86 blind rivets, Blue Bird P/N 0888222, as necessary.
5. Allow the adhesive to cure the proper amount of time (fourteen days at room temperature for the Amicon TX-4009) before returning the vehicle to service.

## SPARE TIRE LOCATION & REMOVAL

If your unit is equipped with a frame mounted spare tire carrier, the following procedure should be used to remove and replace spare:

1. Remove the two securing nuts and rotate tire out of holes.
2. Open access door, if equipped, through access hole, insert lug wrench, placing socket over hex head on shaft and turn clockwise and disengage ratchet.
3. Slowly lower tire by turning counter-clockwise.

**WARNING: Hold wrench securely while lowering tire to prevent weight of tire from causing lug wrench handle to slip out of operator's hand.**

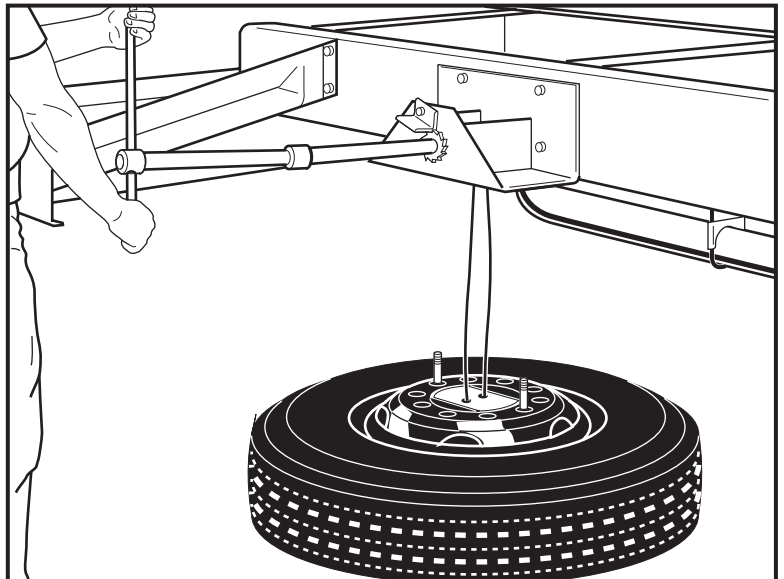

4. Remove lifting platform from tire.
5. To raise tire, reverse procedures, making certain to engage ratchet before cranking clockwise.

**WARNING: At all times stay from beneath tire.**

If your unit is equipped with a spare tire compartment, the following procedure should be used to remove and replace spare:

1. Unlatch the tire compartment door and secure in the open position with the chain and hook.
2. Pull out the rack.
3. Remove the wheel hold down clamp and lift off the wheel. Reverse the procedure above to replace the wheel.

**WARNING: At all times stay from beneath tire.**

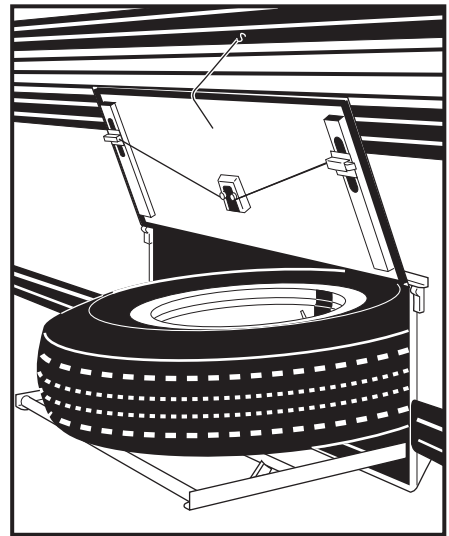

## **TIRES, WHEELS & RIMS**

**WARNING: An inflated tire and rim can be very dangerous when it is misused or worn out. Many accidents, some fatal, have resulted from improper handling and operation of bus rims and wheels. It is, therefore, of the utmost importance that the precautions outlined on these pages be carefully followed by all persons servicing bus rims and wheels to avoid personal injuries and costly damage.**

Both the tubeless type and tube type tires are used on the TC. The tubeless tires are mounted on 15 degree drop-center rims and wheels. The tube type tires are mounted on two-piece flat base rims or wheels or three-piece flat base rims or wheels.

### **DAMAGED TIRES**

**WARNING: To help avoid personal injury and/or property damage if a blowout or other tire damage occurs, obtain expert tire service help if you can. If you must remove the wheel and change the tire without such help, take the following precautions:**

- If the tire looks as if it may contain air under pressure, stand to the side and check whether the wheel assembly appears normal by comparing it to another wheel assembly on the vehicle. Check whether the side ring and lock ring around the wheel rim (if so equipped) are seated properly for duals, look between the tires to check this. If they look as if they are not seated properly, or if you cannot be sure, stay away from the tire and wheel and do not attempt further repair without expert tire service help.
- If the side ring and lock ring appear to be seated properly (or the wheel is not so equipped), let the air out of the tire by taking out the valve core. If you have a way to put air back in a tire, note that it is good safety practice to let the air out of both tires of a dual assembly before taking off the damaged tire and rim assembly from the vehicle. After letting out the air, take off the tire and rim assembly and put on the spare wheel and tire assembly.
- If you are not fully expert on the procedures to follow, and /or are not equipped with the proper tools and equipment, again, do not attempt to raise the vehicle, or remove or install the tire and wheel assembly obtain expert tire service help.
- Do not put air back in a tire that has been run flat, or is seriously low on air, without first having the tire taken off the wheel and the tire and tube checked for damage.

- Note that taking off and putting tires on bus wheels requires proper tools, safety equipment and special training. A person can be badly injured and/or damage can result from using the wrong service methods. Bus tires and wheels should be serviced only by trained people using the proper equipment.
- When putting air in a tire on the vehicle, stand to the side and use a clip-on chuck and hose extension. Never add to your tires unless an accurate pressure gauge is also used. In choosing the right tire pressure, be careful not to go past the maximum pressure capacity shown on the tire.

**CAUTION: Tire inflation pressure must not exceed the recommendations of the tire and/or wheel rim manufacturer for the specific load, speed and application. The inflation pressure on the tire sidewall does not take the wheel or rim capacities into consideration. Tires should not be inflated above the pressure listed on the label without consulting your tire/wheel distributor.**

### **WHEEL AND RIM - SAFETY**

Wheels must be properly maintained because improperly maintained wheels and wheel components can adversely affect the life of the tire and wheel. A tire when inflated is potentially very destructive. Accidents are caused by careless handling and inexperience. You must follow the safety procedures as outlined by the following: Obtain safety literature from your wheel and rim distributor, a wheel and rim manufacturer, NHTSA or OSHA, or, in addition, if you have any questions, consult the distributor or manufacturer directly. The load carrying requirements of each vehicle should also be determined before selecting the proper tire / wheel combination. Always remember that the weakest weight carrying component vehicle (i.e., tire, wheel, axle, bearings, etc.) determines its overall maximum and safe load carrying capacity for the vehicle.

**WARNING: There have been many reported injuries and deaths from improper handling of wheels and rims. Failure to follow directions is the leading cause of such accidents. Obtain procedures from wheel and rim manufacturer before working with a wheel or rim. Follow also the following rules:**

The tire and wheel must always be properly matched. Do not mount a 20 inch tire on a 22 1/2 inch wheel. Failure to strictly adhere to these important instructions will result in an explosive separation and will cause serious bodily injury or death. It is very important to determine the size of each component before any assembly operations commence.

When replacing tires, use the same size, load range and construction type as originally installed on the vehicle. When replacing wheels, use original equipment manufacturer's wheels or equivalent available from your dealer with equivalent capacity, width, offset and mounting configuration as those originally installed on your vehicle. Use of improper replacement wheels and tires may adversely affect ride, handling, load carrying capacity, bearing life, the clearance to body and chassis components, vehicle ground clearance, vehicle width and brake cooling. Do not intermix rim, lock ring and wheel components from different manufacturers.

## TIGHTENING WHEEL STUD NUTS

**CAUTION:** When the bus, or wheels or fasteners are new, have a technician tighten wheel stud nuts and/or rim clamp nuts with a torque wrench at 100, 500 and 1000 miles (180, 800 and 1600 kilometers). This precaution is necessary because the clamping system used on the wheels must seat before the fasteners will hold a uniform clamp load and remain fully tightened. Also, have a technician tighten wheel stud nuts and/or rim clamp nuts with a wrench after installing any wheel. In addition, nut tightness on all wheels should be set with a torque wrench every 1000 miles (1600 kilometers).

The following procedures, as applicable, should be used when installing or tightening wheels.

### DISC WHEEL

Mount front wheel or inner dual wheel over studs, being careful not to damage stud threads. Draw up nuts alternately in the sequence as shown. Do not tighten them fully. (Tighten nuts to 450 - 500 ft. lbs. using the same alternate sequence.) Mount the outer wheel and repeat the entire procedure. Torque outer nuts to 450-500 ft. lbs.

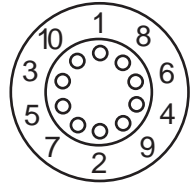

### SPOKE WHEELS

Place rims and spacer band on wheel. Secure clamps evenly in position by tightening the nuts by hand. Tighten the nuts to 50 ft. lbs. using the alternate sequence as shown. Check the wheel wobble, then rotate the wheel so that the furthest position out is at the top. Tighten the nuts to 100-150 ft. lbs. using the procedure shown. Torque the nuts to 200-250 ft. lbs. using the procedure shown.

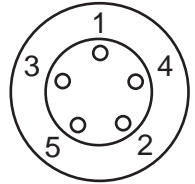

**NOTE:** For dual tire installations, position outer tire and wheel assembly so that valve stems will be in adjacent holes or spaces.

Tire size, rim size and tire inflation pressure can be located on certification plate located in driver's area.

## JACKING INSTRUCTIONS

1. Park vehicle on flat, level concrete or comparable surface capable of supporting jacking device.
2. Apply parking brakes.
3. Place chocks at front and rear of tires opposite wheel/or wheels to be lifted first.
4. Use jacks and jack stands or blocks of sufficient capacity to support the vehicle. Following the jack manufacturer's recommended procedure, place jack securely under axle at spring or suspension beam and lift to required height for servicing. Be sure any locking device on the jack is in place and operating and solidly support the vehicle under the main frame rails with jack stands or blocks before working under or around the bus.
5. After servicing is complete, reverse above procedure.

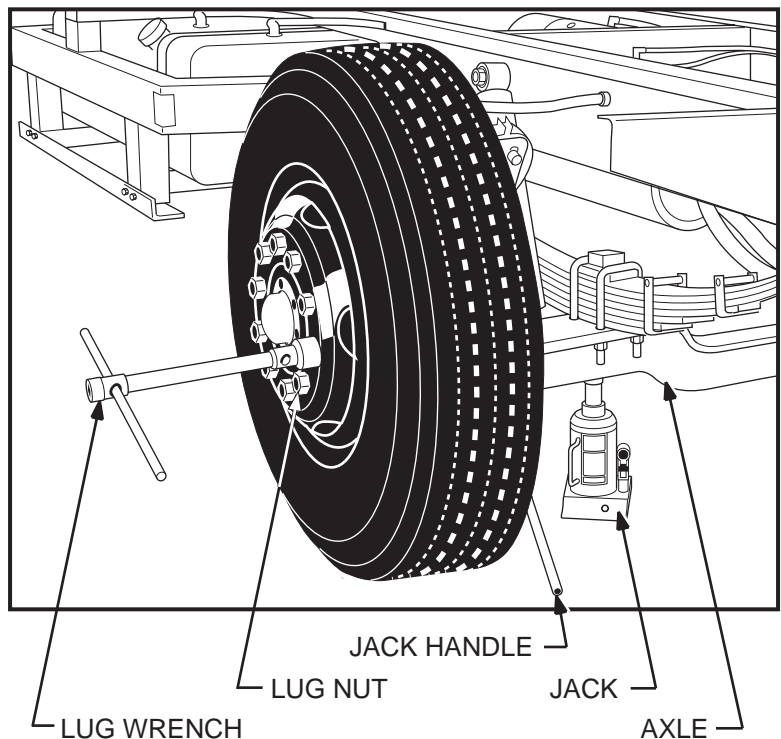

# **ENGINE OPERATING INSTRUCTIONS**

## **ENGINE EXHAUST CAUTION DIESEL & GAS**

**(Carbon Monoxide)**

**WARNING: Never idle engine in closed areas. Never sit in a parked or stopped vehicle for any extended amount of time with the engine running. Exhaust gases, particularly carbon monoxide, may build up. These gases are harmful and potentially lethal. Carbon monoxide is colorless and odorless, but can be present with all other exhaust fumes. Therefore, if you ever smell exhaust fumes of any kind inside your vehicle, have it inspected immediately by your dealer and have the condition corrected. Do not drive with exhaust fumes present.**

Avoid inhaling exhaust gases because they contain carbon monoxide, which by itself is colorless and odorless. Carbon monoxide is a dangerous gas that can cause unconsciousness and is potentially lethal.

If at any time you suspect that exhaust fumes are entering the bus, have the cause determined and corrected as soon as possible.

The best protection against carbon monoxide entry into the bus is a properly maintained engine exhaust system, body and body ventilation system. It is recommended that the exhaust system and body be inspected by a competent mechanic:

- Each time the vehicle is raised for oil change
- Whenever a change is noticed in the sound of the exhaust system.
- Whenever the exhaust system under body or rear of the vehicle is damaged.
- Inspection of all piping and joints - replace clamps if leaking. **NOTE:** Clamps are not reusable. Reseal with exhaust sealant and install new clamp.

Do not run engine in confined areas such as garages any more than needed to move vehicle in or out of area. When vehicle is stopped in an unconfined area with engine running for any more than a short period, the following precaution should be observed: (**Note**, This is provided the bus is equipped with combination heating and external ventilation.)

Adjust heating or ventilation system to force outside air into bus with blower set at medium or high speed.

**Remember:** Keep air inlet grille clear of snow or other obstructions at all times to assure proper operation of the ventilation system.

Sitting in a parked vehicle with engine running for an extended period is dangerous.

## **DIESEL ENGINE STARTING PROCEDURE**

1. Apply parking brake.
2. Place transmission shift lever in neutral position .
3. See appropriate engine manufacturers operating manual for proper starting procedures. Starting procedures vary from different engine manufacturers and also varies with temperature.
4. After engine starts, release accelerator to maintain a fast idle (1000-1600 rpm) until the engine is warmed up.

**IMPORTANT:** Do not keep starter engaged for more than maximum of 30 seconds followed by 120 seconds (2 minutes) off time. If engine fails to start after a reasonable time, determine cause of failure. Pumping the accelerator will in no way assist in starting the engine. Refer to engine manufacturers recommended procedures. **DO NOT RACE THE ENGINE TO SPEED WARM-UP!**

## **STARTING WITH BOOST CABLES**

**WARNING: Batteries give off flammable fumes that can explode. Prevent sparks near the batteries. They could cause vapors to explode. Do not allow battery cable ends to contact each other or the engine.**

**CAUTION: Do not smoke when observing the battery electrolyte levels. Electrolyte is an acid and can cause personal injury if it contacts skin or eyes. Always wear protective glasses when working with batteries.**



Your bus has a 12-volt starting system. Use only the same voltage for boost starting. The use of a higher voltage will damage the electrical system.

Always connect the boost cables in parallel with the bus battery cables, **Negative (-) to Negative (-) and Positive (+) to Positive (+)**. Do not reverse the battery cables. The alternator can be damaged. Attach ground cable last and remove first.

1. Fasten the positive (+) clamp of the boost cable to the positive (+) post of the battery.
2. Fasten the negative (-) clamp of the boost cable to the negative (-) post of the battery.
3. Start the engine.
4. After the engine starts, disconnect the negative (-) boost cable from the battery.
5. Disconnect the positive (+) boost cable from the battery.

### **COLD START AID (OPTIONAL)**

The COLD START AID is designed as an aid to start the diesel engine in temperatures below freezing. This cold start aid utilizes a pressurized cylinder of Ethyl Ether which is injected into the intake manifold on the engine. The Ether may be injected prior to cranking. To operate, press button for 1 second and release. Wait 2 seconds and engage starter. For temperature below zero, repeat the above steps. Use the aid only for starting. NOTE: Not available with electronic engines.

**WARNING: Ether starting fluid is highly flammable and toxic. Observe the precautions printed on the container when using or storing this fluid and when discarding the empty containers.**

**NOTE:** Ether capsule starting aids, or spraying ether into the air intake system, is not recommended.

### **USING ENGINE AS A BRAKE**

In descending a steep or long grade it is a good practice to use the engine as a brake to retard vehicle speed. Reduce speed before the grade and shift into a lower gear (with either automatic or manual transmissions), being careful to select a gear which will slow the vehicle without overspeeding the engine. Under such conditions, use the brakes sparingly to prevent them from overheating, which reduces brake effectiveness.

**WARNING: Do not take transmission out of gear when going down a steep or long grade. You may not be able to get the transmission back in gear, and the drastic slowing of engine speed could reduce air pressure supply to the air brake system, and result in a reduction of brake capacity.**

### **ENGINE WARNING SYSTEM**

Your unit may have an optional alarm system to signal low oil pressure and high engine temperature. If the engine temperature exceeds 210 degrees, or if the oil pressure drops below 6 PSI, a buzzer sounds and an indicator light glows.

**CAUTION: If the alarm system sounds, shut the engine off immediately. Operation of the engine after the alarm sounds could cause serious engine damage.**

## ANTIFREEZE

The unit is equipped with a 50-50 solution of antifreeze and water. This mixture protects to -30 degrees F. The driver should check antifreeze before taking unit into cold climate. For protection to 92 degrees F. below zero, the mixture should be 68 percent antifreeze and 32 percent water. Never have more than 68 percent antifreeze.

**CAUTION: Cold water should never be poured into the cooling system when engine is hot. Wait until engine cools, then add coolant with engine running.**

**WARNING: Extreme care must be used when removing radiator cap. As coolant becomes hot, pressure is built up in the cooling system. Rapid venting and/or removal of radiator cap will cause coolant to boil up and spray out and can result in serious burns. Slowly vent off pressure before removing radiator cap.**

## NOISE EMISSIONS WARRANTY

Blue Bird Body Company warrants to the first person who purchases this vehicle for purposes other than resale and to each subsequent purchaser that this vehicle, as manufactured by Blue Bird, was designed, built and equipped to conform at the time it left Blue Bird control to all applicable U.S. EPA Noise Control Regulations.

This warranty covers this vehicle as designed, built and equipped by Blue Bird and is not limited to any particular part, component or system of the vehicle manufactured by Blue Bird. Defects in design, assembly or in any part, component or system of the vehicle as manufactured by Blue Bird, which at the time it left Blue Bird control, caused noise emissions to exceed Federal standards, are covered by this warranty for the life of the vehicle.

## FUEL & LUBRICANT REQUIREMENTS

### DIESEL FUEL

TC units should take advantage of the high energy content and generally lower cost of No. 2 diesel fuel. Experience has shown that diesel engines will operate satisfactorily on No. 1 fuel.

**CAUTION: This coach is equipped with a side mounted 60 gallon fuel tank. Use caution when filling with a high delivery nozzle to prevent spillage.**

**WARNING: FUEL SPRAY MAY CAUSE INJURY, REMOVE CAP SLOWLY. Do not fill more than 95% of liquid capacity.**

### RECOMMENDED LUBRICANT

**CAUTION: Do not mix petroleum based and synthetic lubricants or different brands of synthetic lubricants due to possible incompatibility. In addition there may be increased lubricant change intervals recommended for synthetic lubricants. Consult manufacturers label for lubricant requirements.**

1. Manual Transmission - Refer to Spicer Transmission Service Manual.
2. Automatic Transmission - Refer to Allison Automatic Transmission Driver's Handbook.
3. Rear Axle - Refer to Dana Maintenance Manual.
4. Hydraulic Power Steering Pump - Dexron.

**NOTE:** For engine oil lubricant, follow engine manufacturer's recommendations for SAE grades.

# COMPRESSED NATURAL GAS

---

## INTRODUCTION

The compressed natural gas (CNG) fuel system consist of DOT certified storage tanks that store CNG at up to 3000 psi that replace the fuel tank, a structure to hold and protect the tanks, metallic fuel lines to deliver the fuel, high and low pressure regulators to reduce the pressure entering the throttle body, a fuel shut-off solenoid and the throttle body which delivers the CNG/air mixture to the engine. The regulator includes an integral heater to preheat the CNG for anti-icing control.

A pressure relief system is part of the fuel system. This system is designed to vent the tank contents when pressure and temperature become excessive.

A fill connection is located near the entrance of the bus.

If so equipped, the engine powering this bus is engineered specifically for use with CNG. Operation and maintenance procedures are similar to those used on gasoline or diesel engine vehicles. Differences identified are obvious.

## OWNER / OPERATOR RESPONSIBILITIES

The owner/operator should be aware of the code requirements and be familiar with applicable codes which apply to the area of operation. The owner/operator should be aware that fuel cylinders for CNG (Compressed Natural Gas) must be inspected every three (3) years in accordance with NGV-2 specifications. The owner/operator should be aware that cylinder expiration date is fifteen (15) years after date of cylinder manufacture and that cylinders must be replaced. This testing and certification is not covered by Blue Bird warranty.

**WARNING: Due to the dangerous potential of high pressure cylinders, it is suggested that anyone involved in their use be completely familiar with the Department of Transportation "Code of Federal Regulations Title 49" and the various Compressed Gas Association pamphlets that are available covering the care and use of high pressure cylinders. Regulations do not permit filling NGV cylinders with an over-charge.**

## NATIONAL FIRE PROTECTION ASSOCIATION # 52 states:

Cylinders shall be manufactured, inspected, marked, tested, retested, equipped and used in accordance with U.S. Department of Transportation (DOT) or Canadian Transport Commission (CTC) regulations, exemptions or special permits specifically for CNG service and shall have a rated service pressure of not less than 2400 psig at 70 Deg. F. (16.5 MPa at 21.1 Deg. C).

Pressure vessels shall be manufactured, inspected, marked and tested in accordance with the rules for construction of unfired pressure vessels, Section VIII (Division 1), ASME Boiler and Pressure Vessel Code.

When a vehicle is involved in an accident or fire causing damage to the CNG container, the CNG container shall be replaced or removed, inspected and retested in accordance with the document under which it was originally manufactured before being returned to service.

When a vehicle is involved in an accident or fire causing damage to any part of the CNG fuel system, the system shall be retested before being returned to service.

Damaged supply lines shall be replaced, not repaired.

The owner or user or both shall maintain all containers, container appurtenances, piping systems, venting systems and other components in a safe condition.

As a precaution to keep pressure relief devices in reliable operating condition, care shall be taken in the handling or storing of compressed natural gas containers to avoid damage. Care shall also be exercised to avoid plugging by paint or other dirt accumulation of pressure relief device channels or other parts which could interfere with the functioning of the device. Only qualified personnel shall be allowed to service pressure relief devices. Only assemblies or original manufacturer's parts shall be used in the repair of pressure relief devices unless the interchange of parts has been proved by suitable tests.

## CODE OF FEDERAL REGULATIONS #49 states

In addition to the requirements of this paragraph, cylinders marked DOT-3HT must be requalified in accordance with CGA pamphlet C-8 and must comply with the following:

Cylinders built prior to implementation of FMVSS 304 must be subjected, at least once in three years, to a test by hydrostatic pressure in a water jacket, for the determination of the expansion of the cylinder. A cylinder must be condemned if the elastic expansion exceeds the marked rejection elastic expansion.

Cylinder service life must not exceed 15 years.

Each cylinder must be reinspected and hydrostatically retested every three years in accordance with 49 CFR 173.34(e) as prescribed for DOT-8HT cylinders, except that the rejection elastic expansion criteria does not apply, permanent volumetric expansion must not exceed 5 percent of total volumetric expansion at test pressure and retest dates must be imbedded in the epoxy coatings in a permanent manner other than stamping. Retest dates may be steel stamped on the shoulder of the top head in accordance with 178.BB-15(c). Reheat treatment or repair of cylinders not authorized.

## FUEL SYSTEM DESCRIPTION

The fuel system begins with DOT certified tanks to hold compressed natural gas (CNG) up to 3600 psi, corrected to standard day temperature. The tanks are high strength aluminum wrapped with fiberglass for further strength.

The fuel exits the tank in route to the engine through manually controlled shutoff valves. These include an integral pressure relief valve consisting of a combination rupture disk (for pressure) and fuse plug (for temperature) to vent the contents of the tank should high pressure and high temperature occur, such as in a fire. The rated pressure and temperature for relief is 212 degrees Fahrenheit.

From the valve fuel flows into a common fuel line through high pressure stainless steel compression fittings. The tanks are joined to the common line through high pressure stainless steel tee's and crosses. Any open tank thus communicates to any other open tank. So for fueling, the fuel is backfed through the common line to all tanks (with open valves) simultaneously. The tank shutoff valves only isolate the interior of the tanks: The tee's on the valves still have the high line pressure.

Do not uncouple fittings until all tanks are closed and pressure has been purged from the line.

The lines are high pressure rated 3/8 stainless steel seamless tubing which carries the fuel to the high pressure regulator.

In refilling, the fuel enters the fill valve on the entrance side of the bus and then flows through a check valve into the common tubing before reaching the tanks.

From the high pressure regulator, the fuel flows to the shutoff solenoid. The shutoff solenoid is activated by the ignition switch, engine operation, and the fire suppression system. The loss of any of these will shut off fuel supply to the low pressure regulator (LPR).

The dashboard fuel gauge is proportional to the pressure when corrected to 70 degrees Fahrenheit.

**NOTE:** Fuel level is only accurate for the tanks that are open.

## SAFETY CAUTIONS & WARNINGS

Both gasoline and CNG are volatile flammable fuels that are safe to work around when necessary precautions are taken. As on a gasoline fueled system, carelessness with CNG can lead to a fire or explosion when a leak occurs. CNG will not pool and spread like gasoline. It has a narrower range of flammability than gasoline as well as a higher ignition temperature. Despite these relative safety advantages, fire potential does exist. CNG is lighter than air, therefore, it can collect in the higher regions of a room and possibly go undetected, creating fire potential.

Since the fuel system is a very high pressure system employing a flammable gas, all safety issues normally considered in these situations should be applied. Some of the more obvious precautions are listed below. This list is not necessarily intended to be complete, and responsibility for assuring full safety is that of the person(s) doing the work or operating the system.

**WARNING:** Handle natural gas with care. Compressed natural gas is a volatile fuel stored under high pressure. If fuel storage or delivery components are installed, serviced or operated improperly, fire, explosion and/or serious injury could result. Do NOT smoke while working on or around natural gas equipment. Avoid flames, sparks and operation of electrical devices in or around a vehicle with a possible natural gas leak. Properly tighten all connections and thoroughly check for leaks after servicing fuel system. Natural gas fumes may cause sickness or death. Work in well ventilated area.

**WARNING:** Protect against high pressure CNG. Compressed natural gas is stored and routed to the engine at a pressure up to 3600 psi. Do NOT attempt to remove or disassemble any fuel system component while it is pressurized. Explosive separation of components and escaping natural gas can cause serious injury. Avoid the hazard by relieving pressure before disconnecting any CNG fitting or line. Properly tighten all connections and thoroughly check for leaks before applying pressure. Never attempt to over pressurize the system.

**WARNING:** Protect against extremely cold escaping CNG. Compressed natural gas is stored at an extremely high pressure. If compressed natural gas escapes from a leak, it will expand into and extremely cold (-260 deg F) gas. Severe frost bite may occur from contact with escaping natural gas or its associated components. Avoid the hazard by relieving the pressure before disconnecting any CNG fitting or line. Properly tighten all connections and thoroughly check for leaks before applying pressure.

**WARNING:** Storage tanks must be tested according to specified procedures at required dates. Failure to do so relieves the manufacturer of all responsibility and is a violation of federal law. See manufacturer's label.

**CAUTION:** In the event of an accident, all tanks, lines and fittings should be thoroughly checked by qualified personnel before the vehicle is used again.

**NOTE:** All valves are closed when turned fully clockwise viewed from the top of the valve handle, and open when turned counterclockwise viewed from the top of the valve handle.

**CAUTION:** Always provide good ventilation, including near roofs and ceiling.

**CAUTION:** Do not work in a noisy environment, the sound of leaking gas may go undetected.

**WARNING:** Never attempt to find a leak with your hands. A large leak can freeze burn the skin.

**WARNING:** Never place hands or any other part of the body on a leak.

**IMPORTANT:** Always have rated fire extinguishers on hand and automatic fire suppression equipment.

**CAUTION:** Avoid heat near pressure relief valves; the manufacturer's rating is 212 degrees Fahrenheit for the relief valve. Should it vent, the entire area will be filled with natural gas.

**IMPORTANT:** Rust or corrosion on tanks, lines, fittings and valves can be a serious problem. Any part with serious corrosion should be replaced.

**IMPORTANT:** Fiberglass coating on tanks should be in excellent condition. Any cracks or serious scrapes may require tank replacement. Contact the manufacturer.

**WARNING:** Tanks cannot be filled to more than 3000 psi or 3600 psi temperature corrected.

**IMPORTANT:** Use only authorized refueling stations with adequate pressure controls and venting capacity.

**NOTE:** Venting contents of tanks should follow any federal and state guidelines, including EPA.

**WARNING:** Use only fuel connections designed for use with that on the bus. Do not attempt to force damaged fittings.

**WARNING:** Keep sources of heat and ignition away from fuel system and refueling apparatus.

For more information see drawing #1589001 in the owners information package supplied with the vehicle.

### **COMPRESSED NATURAL GAS FUEL**

The performance and reliability of a Natural Gas Vehicle is dependent upon the quality of fuel used. BTU content of natural gas can vary depending on locale. Excessive moisture can cause driveability problems, loss of power and regulator freezing. Other contaminants, specifically lubricants and oil, can cause serious damage which is not covered by the engine manufacturer's warranty. In addition, poor quality fuel can affect emission certification.

**CAUTION:** It is the owner's/operator's responsibility to insure that clean, quality fuel is used to prevent damage to the fuel system components and power plant. Damage caused by poor quality fuel is not covered by Blue Bird warranty.

Fuel control systems used on engines fueled by compressed natural gas contain electronic sensors and other delicate components which are not tolerant to contaminants. Vehicle performance is dependent upon clean fuel and regular scheduled vehicle maintenance.

Compressed natural gas is expected to be delivered from the compressor station and storage cascade free of contaminants including oil, water, and particulates.

Conditions exist in some CNG fill stations that cause inferior fuel to be loaded in the vehicles fuel storage system.

The driving range of a natural gas vehicle is dependent upon driver, fuel BTU content, vehicle weight, gear ratio, tire size, terrain, engine tune and condition, frequency of starts and stops, full load of fuel and other factors.

### **COMPRESSED NATURAL GAS FILTERS**

Particulate and coalescer type filters are installed in Blue Bird CNG fuel systems. The primary filter is of stainless steel construction and is located at the fill point. This filter can be checked for contamination by closing main shutoff valve on frame and then relieving pressure which is trapped between the check valve in the fill nozzle and the main system check valve. The owner/operator should establish a service interval based on quality of gas from the compressor station. It is recommended that the filter sump be checked after the initial fill and several fills after and then develop a schedule based on need; every fill or every fifth fill or longer.

The secondary filter has a black anodized housing and is adjacent to the fuel shutoff solenoid close to the engine. The secondary filter can be checked after relieving system pressure. This is best accomplished by closing the main shutoff on frame and running engine until fuel supply is depleted and pressure is zero. Contamination of the secondary filter should not occur if a proper maintenance schedule has been followed at the fill point primary filter. Contamination of the secondary filter also shows that CNG storage cylinders on the vehicle are contaminated. The owner/operator should insist that fuel from a compressor station should be clean and dry.

Replacement filter elements are available through the Blue Bird Service Department.

**WARNING:** Natural gas is extremely flammable and high pressure gas can cause personal injury, loss of sight, or death.

## FUEL COMPOSITION

Natural gas composition varies throughout the country, depending on original gas composition and processing. Pipeline quality natural gas is composed of several different gases, of which methane typically accounts for 85 to 99%. Other hydrocarbons present in natural gas include ethane, propane, some butanes, and trace amounts of other hydrocarbons. Nitrogen, helium, carbon dioxide, and trace amounts of hydrogen sulfide, water, and odorants are also present. Most natural gas available does not vary significantly in content; however, significant variations are more likely from small gas utilities. The removal of all carbon dioxide, water, hydrogen sulfide, and odorants is required for liquefaction, thus LNG does not contain these constituents.

The importance of gas composition to users of NGVs is as follows:

Large amounts of non-methane hydrocarbons will enrich the fuel mixture, reduce the octane number, lead to increased hydrocarbon emissions, and increase the potential for engine knock. Accordingly, engine parameters such as air / fuel mixture and ignition timing should be adjusted on the basis of the composition of the local natural gas supply.

## REFUELING

**CAUTION: Refueling must be conducted in well ventilated areas to prevent accumulation of dangerous gas levels.**

The National Fire Protection Association has recommended guidelines for CNG refueling systems. State and local regulation regarding NGV refueling may preclude economic feasibility of indoor refueling (such as in New York City). However, the significance of this issue may diminish if increased experience with fuel leads to less stringent regulations.

CNG refueling transfers natural gas under pressure and may be set up as either slow-fill or fast-fill. Slow-fill generally uses overnight refueling and requires less costly refueling station equipment than fast-fill. However, fast-fill refueling time is only slightly longer than gasoline refueling time. LNG refueling transfers a cold (-260°F) liquid under pressure (around 15 psi) and generally takes slightly longer than conventional refueling because a greater volume of liquid is transferred to compensate for its lower energy content.

The refueling station has a supply connection hose and a coupling which must be properly attached to the fuel system fill valve. The supply side is regulated for maximum pressure and uses a proper purge valve when decoupling from the filler. The regulators and relief valves of the fill station must be checked for proper values and operation.

Fuel enters the bus coupling from the filler connection, travels through a one-way check valve into the fuel lines and then into any open tanks. Any tank that is open is in communication with any other open tank through the common fuel lines.

**CAUTION: Do not refill with the engine running or any source of ignition or heat nearby. The refueling station must be in a safe working condition with approved operable relief and vent valves.**

**NOTE:** A ground stud is provided for attachment of the grounding cable at the compressor station. Check that the tank shutoff valves are open. Any tank with an open valve will be filled, any tank with a closed valve will not. If the bus has been operating with some tanks closed, it is preferable to fill the empty tanks first and then fill the remainder. Fill to the desired pressure. Maximum is 3000 psi temperature corrected to 70 degrees Fahrenheit. (**NOTE:** Most fill stations have a dome valve to automatically make the temperature correction.) When fueling is complete, open the fill connector purge valve. Use only fuel filling couplings designed for use with the CNG. Do not force damaged couplings together.

**CAUTION: A check valve is included in the system behind the fill connector to prevent backflow of fuel when purging and disconnecting the fuel nozzle**

**NOTE:** The tanks are full at 3000 psi or 3600 psi and 70 degrees Fahrenheit. The pressure will vary with temperature. Decreasing with lower temperature and increasing with higher temperatures. Filling apparatus compensates for the temperature effect.

**WARNING: Never fill to more than permissible pressure. Contact the manufacturer if an accidental overflow occurs.**

**NOTE:** The fuel level is only accurate for tanks that are open. For example, if one tank is open and reads 1000 psi, then the fuel available to the engine is proportionate to the total capacity.

### SPECIFIC GRAVITY

The specific gravity of natural gas relative to air (air=1.00) is 0.56 to 0.62 depending on gas composition. This indicates that natural gas is lighter than air. In the event of a natural gas leak, the gas will rise and dissipate given open conditions. There is no possibility of CNG accumulating in pools on the ground beneath a spill.

**NOTE:** Natural gas odorants allow its detection by humans before dangerous concentrations are reached.

In the case of LNG releases, the cold vapor initially released is heavier than the surrounding warmer air and thus stays low, near the ground (a visible vapor cloud is often formed from the condensation of water in the cold air-gas mixture). As the vapor cloud warms, it will increase in volume, become lighter than air, and rapidly dissipate.

### FUEL TOXICITY AND SAFETY

Natural gas is a nontoxic gas. It is flammable under proper conditions. Additionally, it can cause suffocation if enough oxygen is displaced. LNG has the added safety concern of being a cold (-260°F) liquid under pressure. Severe frostbite may occur from contact with LNG or associated cold components. Furthermore, many common materials change their strength characteristics when exposed to LNG temperatures, thus presenting additional hazards.

**WARNING: LNG tanks have the potential for explosions under circumstances such as those described for LPG explosions.**

Although natural gas has odorants to aid in detection of leaks, these odorants are removed during liquefaction, thus LNG vapors can not be detected by smell. (**NOTE:** LNG odorants have been developed but are not commonly used due to the relatively restricted use of LNG at this time).

### FLAMMABILITY

Autoignition temperature for natural gas at atmospheric pressure is 1004°F compared to an autoignition temperature range of 442 to 880°F for gasoline and approximately 500°F for diesel fuel. The risk of fire in the presence of an ignition source exists when the ratio of air to fuel is within flammability limits (i.e., fuel can not ignite if it is mixed with too much or too little oxygen). The flammability limits for natural gas are 5.3 to 15% volume of gas in air. For comparison, the flammability limits of unleaded gasoline are 1 to 7.6% volume of gasoline in air. As a practical matter, there is no oxygen present in CNG cylinders or LNG tanks, therefore ignition within the cylinder or tank is not possible. In the event of fuel leak, there will be a small area in which the air to fuel ratio is within the flammability limits. In a closed garage, or within the passenger compartment, ignition conditions are more likely to be met. Odorants used in CNG allow its detection before the lower flammability limit has been reached.



## ANTIKNOCK PROPERTIES

Natural gas has a research octane rating of about 130, making it relatively resistant to engine knock. The antiknock property is a result of the high ignition temperature, resistance to autoignition, and the relatively low flame speed of natural gas. Antiknock properties allow the use of engine compression ratios in the range of 15:1 (compared to 8:1 to 10:1 for gasoline). The low flame speed of natural gas results in a longer duration of combustion. To compensate for the lower flame speed, ignition timing is advanced. As with other fuels, knock may occur with advanced ignition timing, prolonged combustion (i.e. too lean mixture), and excessively high compression ratios.

## ENERGY CONVERSIONS

- 100 - 125 cubic feet NG = 1.0 gallon gasoline
- 136 cubic feet NG = 1.0 gallon diesel
- 1 cubic foot NG = 1000 Btu
- 114,000 Btu = 1.0 gallon gasoline
- 83,700 Btu = 1.0 gallon LNG

## VEHICLE PERFORMANCE AND EMISSIONS

NGV performance, fuel economy, and emissions can be significantly altered with vehicle tuning (e.g., ignition timing, air/fuel ratio). Appropriate tuning adjustments can optimize either performance, fuel economy, or emissions. Alternatively, a compromise tuning may be effected. Tuning optimization for power generally increases emissions. Substantial improvements in performance and emissions can be obtained using natural gas conversion kits that are specially designed for a given vehicle make and model. Further improvements can be achieved with factory built, dedicated NGVs.

## STARTING PROCEDURE

Make sure that the main shutoff valve and at least one tank valve are open. The fuel gauge shows empty if no fuel is available to the mixer. Check the tank and main fuel shutoff valves if no fuel is indicated on the fuel gauge.

**NOTE:** Fuel gauge takes time to register after turning the key.

Starting procedures are identical to those of a gasoline engine vehicle. With the vehicle in neutral, turn the key until the engine catches. Do not press the accelerator. If the engine has trouble starting depress the accelerator slightly and release when the engine catches. Pumping the accelerator in no way assists in starting the engine.

Engine operation and characteristics should be similar to those of a gasoline engine.

**NOTE:** If the batteries have been disconnected on a unit equipped with the John Deere 8.1 CNG engine for service reasons and then reconnected the engine will idle rough for up to five minutes after restart until the Electronic Control Module is readjusted automatically. Only idle is affected.

## COLD START

For cold starts in low ambient temperatures, natural gas has an advantage over liquid fuels because it is already in the vapor phase. With correct conversion kit installation and vehicle maintenance, cold start ability is better with natural gas than gasoline.

## OPERATION & MAINTENANCE of VEHICLE COMPONENTS

CNG vehicles require Department of Transportation (DOT) certified cylinders for the storage of pressurized (maximum 3600 psi) natural gas. Refueling port and lines with pressure safety valves must also be installed. High pressure fuel lines from the storage cylinder lead to a pressure regulator/reducer, which reduces gas pressure in one or two steps. In a fuel injected converted vehicle, a mixer/carburetor must be added for the injection of natural gas. In carbureted fuel systems, a specialized mixer/carburetor for natural

gas may be installed. LNG vehicles require insulated, pressurized (10 to 35 psi) fuel tanks. LNG is vaporized in the fuel line and warmed in the heat exchanger generally located under the hood. Pressure is reduced by the pressure regulator before the vapors are transported to the mixer/carburetor.

## MAINTENANCE

Service manuals supplied by converters and installers should be consulted for maintenance of NGV-specific parts. Components such as the pressure regulator/reducer can be checked with a pressure gauge to determine if the unit is operating properly. Measurements with an EGA can indicate proper air/fuel mixtures and ignition timing. NGV maintenance issues are briefly listed below.

**CNG Cylinders** - CNG cylinders must periodically be recertified to maintain compliance with DOT standards. The Compressed Gas Association has published several pamphlets with recommendations of standards for the inspection of compressed gas cylinders.

**Oil Changes** - Due to the clean burning characteristics of natural gas, collection of particulate matter in engine oil does not occur as rapidly as with gasoline. However, even though visual inspection of the oil may indicate that the oil is clean, oil compounds break down under engine heat. These chemical changes reduce the lubricating ability of the oil and stress the engine system. Therefore, it is recommended that the oil should be changed according to manufacturer recommendations, despite oil appearance. (NOTE: Considerably more data is needed to determine the conditions that influence reports of NGV oil maintaining lubricating properties longer than in gasoline engines.)

**Spark Plugs** - Spark plugs should be replaced as recommended by the vehicle manufacturer.

**CAUTION: Do not use CNG pressure or vent lines to clamp, hang, connect or attach any items including harnesses, hoses, power steering hose, refrigerant hoses or any other item.**

## MANUAL FIVE SPEED TRANSMISSION

The standard transmission used in the TCFE is a five-speed Synchro-Mesh transmission. Refer to the gearshift knob for proper shift sequence.

Disengage the clutch and move the lever into first or reverse gear.

If the lever does not engage immediately, let the clutch partially back-up, while keeping a gentle pressure against the shift lever until full engagement is accomplished.

**CAUTION: Do not "ride the clutch" by resting your foot on the clutch when not shifting gears. Do not use the clutch to hold the vehicle at a standstill on an upgrade, as when waiting for a traffic light. Such misuse could cause premature clutch wear and damage.**

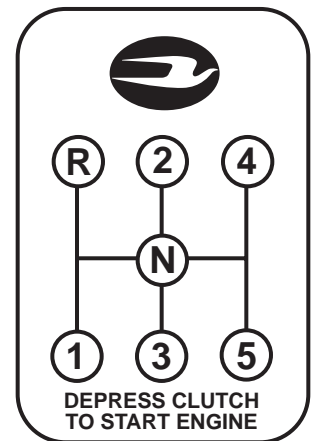

## ALLISON AUTOMATIC TRANSMISSION

### AT 545

The Allison transmission provides four forward speeds and one reverse. Selective control is obtained through the selector lever located on the right area of dash. The selector lever must be in "N" (neutral) to start the engine. If the engine starts in any other position, the neutral start switch is malfunctioning. Use "D" for all normal driving conditions. The vehicle will start in first gear and as you depress the accelerator, the transmission will upshift to second, third and fourth gear automatically. As the vehicle slows down, the transmission

will automatically downshift to the correct gear. Use (3&2) when the road load or traffic conditions make it desirable to restrict the automatic shifting to a lower range. When the conditions improve, return the range selector to the normal driving position. These positions also provide progressively greater engine braking power (the lower the gear range, the greater the braking effect). Use (1) when pulling through mud and snow or driving up steep grades. This position provides maximum engine braking power. Use R (reverse) for backing the vehicle. The vehicle should be completely stopped before shifting from a forward gear to reverse. Reverse gear provides the greatest tractive advantage.

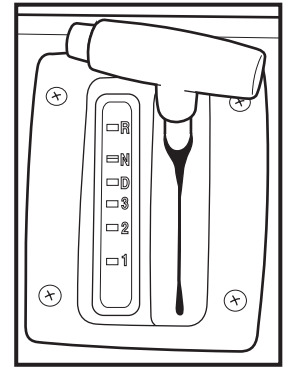

**CAUTION: In the lower ranges (1, 2 and 3) the transmission will upshift above the highest gear selected when the recommended engine governed speed for that gear is exceeded.**

### ALLISON TRANSMISSION CABLE ADJUSTMENTS

To properly adjust the transmission shift cable, the following must be done.

1. Place the selector in neutral with the cable connected at the selector and disconnected at the transmission.
2. Find neutral on the transmission. (This is accomplished by rotating the manual range selector shaft on the transmission all the way counterclockwise, then rotate it one click clockwise.)
3. Adjust the trunnion pin so that it slides easily in and out of the hole in the shift lever on the transmission. Check the neutral safety switch on the selector to be sure the engine will start only in neutral.

Adjust the mechanical modulator per the following procedure:

1. With the modulator cable disconnected at the engine, rotate fuel control lever on the engine to full throttle position.
2. Adjust modulator slip joint to push cable until the cable comes within 1/8 inch of bottoming, when throttle is wide open.
3. Adjust the clevis or trunnion on the end of the cable to permit "free pin" with the fuel control lever. Install and secure the pin.
4. Check accelerator linkage for the proper return to the idle position.
5. Check to be certain there is between 1 3/16" and 1 9/16" travel in modulator cable.
6. If the throttle linkage is readjusted for any reason, the mechanical modulator must be readjusted as above.

### MD3060 WORLD TRANSMISSION

The Allison electronic world transmission provides five forward speeds and one reverse. Fourth gear is a 1 to 1 ratio while the fifth gear is an overdrive with a .75 to 1 ratio. The push-button shift selector is located on the right area of the dash. The transmission and selector must be in "N" neutral to start the engine.

**NOTE:** Transmission and shift selector will return to "N" when engine is stopped and power switched off. If it does not return to "N" or starts in any other gear, unit has malfunctioned. Seek service immediately.

The push-button shift selector has R, N, D, down arrow, up arrow, a MODE button, and a digital display. When a range button has been pressed, a tone will sound, the **SELECT** indicator displays the chosen operation (if Electronic Control Unit (ECU) determines the shift is acceptable), and the transmission will shift to the starting range as indicated on the **MONITOR** display. In Drive, selection of a specific gear can be accomplished by pressing the **UP** or **DOWN** arrow buttons. Conditions resulting in the **CHECK TRANSMISSION** light located below shift selector will disable the pad and no tones will be heard. (See **CHECK TRANSMISSION LIGHT**)

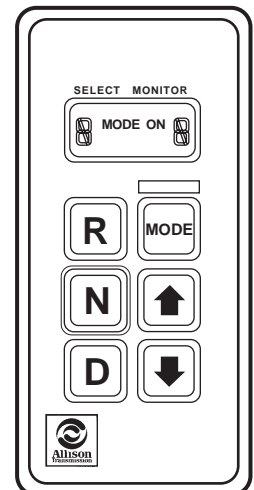

A "MODE" button is located on the push-button shift selector to activate a second shift schedule. The initial start up is in primary (power mode) and secondary (economy mode) is selected by pressing the "MODE" button. The display will indicate the mode on for secondary (economy mode). In economy mode the transmission shift to higher gear at lower engine RPM.

With an Allison MD-equipped vehicle, it is not necessary to select the right moment to upshift or downshift during the changing road and traffic conditions. The Allison MD does it for you. However, knowledge of the gear ranges and when to select them will make vehicle control and your job even easier.

## **MD 3060 GEAR SELECTION**

**WARNING: In the event the operator leaves the vehicle, even momentarily, while the engine is running, be sure that the transmission is in Neutral, parking brake and/or emergency brakes are set and properly engaged, and the wheels are chocked. Unexpected and possible sudden vehicle movement may occur if these precautions are not taken.**

### **R - Reverse**

The vehicle must be completely stopped before shifting from Forward to Reverse or from Reverse to Forward. The **SELECT** indicator will display **R** and the **MONITOR** will display **R** when Reverse is attained.

### **N - Neutral**

Use Neutral to start the engine, to check vehicle accessories, and for extended periods of engine idle operation. Under normal operation, the transmission is directed by the ECU to Neutral during the start-up procedure. This occurs automatically with the push-button selector. If the vehicle starts in any range except Neutral, seek service immediately. Neutral is also used during stationary operation of the power takeoff (if your vehicle is equipped with a PTO). The **SELECT** indicator will display Neutral and the **MONITOR** will display Neutral.

**WARNING: Do not allow your vehicle to coast in Neutral. This practice can result in transmission damage. Also, no engine braking is available in Neutral.**

### **D - Drive**

The vehicle will attain first gear when **D** is selected, and as the speed increases, the transmission will upshift automatically through each gear. As the vehicle slows down, the transmission will downshift automatically. The **SELECT** indicator will display the highest gear available and the Monitor will display the current operating gear.

#### **2, 3, 4, 5 Gears**

Occasionally, the road conditions, load, or traffic conditions will make it desirable to restrict the automatic shifting to a lower gear. Positions **2, 3, 4, 5**, provide progressively greater engine braking for going down grades (the lower the gear, the greater the braking effect). The push-button selector utilizes arrow buttons. Push the **Up** or **Down** arrow to the desired gear. The **SELECT** indicator will display your choice and the **MONITOR** will display the selected gear when it is attained.

#### **1st Gear**

Use position **(1)** gear when pulling through mud and deep snow, when maneuvering in tight spaces, or while driving up or down grades. Low gear provides the vehicle with its maximum driving power and maximum engine braking power.

The transmission incorporates a hold feature to prohibit upshifting above the gear selected during normal driving. For downhill operation, however, the transmission may upshift above the highest selected gear when the engine governed speed is exceeded and damaging engine overspeed is a possibility.

## CHECK TRANSMISSION LIGHT

The "CHECK TRANSMISSION LIGHT" is located on the shifter cover. The electronic control system is programmed to inform you if operating parameters have been exceeded and automatically take action to protect the operator, vehicle, and transmission. A diagnostic code will be registered when the **CHECK TRANSMISSION** light is on and also when other conditions are diagnosed which do not require the **CHECK TRANSMISSION** light to be on.

Every time the engine is started, the **CHECK TRANSMISSION** light comes on then goes off after a few seconds. This momentary lighting is to show that the lighting circuit is working properly. If the light does not come on during engine start, service should be requested immediately.

Illumination of this light, accompanied by 8 seconds of short beeps from the shift selector, indicates that shifts are being restricted. The **SELECT** digit on the display will be blank. Operation may continue in order to reach service assistance. The ECU may not respond to shift selector requests since operating limitations are being placed on the transmission; i.e., upshifts and downshifts may be restricted. **Direction changes will not occur.** For push-button shift selectors, the ECU will not respond to operator requests. The ECU will cause the transmission to shift to a safer gear and a **Hold-In-Range**. See Allison Operator's Manual for Hold-In-Range and reset procedure.

## USING THE ELECTRIC RETARDER (TCFE)

- The electric retarder control switch is mounted on the vertical panel to the left of the driver. It has five positions (one off and four retard positions). Each higher number increases the amount of retardation to slow the vehicle.
- Remember the retarder is a vehicle slowing device, not a stopping device. Final stopping must be accomplished by applying the service brake.
- Always release the accelerator completely before applying the retarder.
- Do not use the retarder when road surfaces are slippery. Minimum applications of retarding effort must be the rule.
- Consult the retarder manufacturer's owner/operator manual for additional information.

## ALLISON AUTOMATIC TRANSMISSION DRIVING TIPS

### ACCELERATOR CONTROL

The pressure of your foot on the accelerator pedal influences the automatic shifting. When the pedal is fully depressed against the pedal stop on the floor, the transmission will automatically upshift near the recommended governed speed for the engine. A partially depressed position of the pedal will cause the upshifts to occur sooner at a lesser engine speed. With AT 545 the timing of the shifts is accomplished by using a cam and cable from the throttle. With MD 3060 an electronic signal tells the ECU how much the operator has depressed the pedal. This provides the accurate shift spacing and control necessary for maximum performance.

### DOWNSHIFT CONTROL AT 545

The transmission can be downshifted or upshifted, even at full throttle, and although there is no speed limitation on upshifting, there is on downshifting and reverse. Good driving practices indicate that downshifting should be avoided when the vehicle is above the maximum speed attainable in the next lower gear. Therefore, good driving habits have been designed into the Allison transmission shift pattern. The downshift inhibitors within the valve body prevent those harmful shifts when the vehicle is going too fast for the next lower gear.

If the downshifts are attempted at excessive speeds, the inhibitors prevent the selected downshift until the vehicle reaches an acceptable speed.

### DOWNSHIFT OR REVERSE INHIBITOR FEATURE With/MD3060

Although there is no limitation on upshifting, there is on downshifting and shifts from Neutral into Drive or Reverse. If a downshift or Neutral-to-Range shift is selected when the engine speed or throttle position is

to high, the ECU will prevent the shift from occurring until a lower speed is reached. If idle speed is too high, shifts to range are inhibited. A continuous "beep" tone is emitted if reverse is selected during forward movement or a neutral-to-range shift is selected at too high an engine speed.

### **COLD WEATHER STARTS MD 3060**

Most World transmissions are programmed to restrict full operation until specific temperatures are reached. Refer to the following chart for temperature restrictions.

<b>Sump Oil Temperature</b>	<b>CHECK TRANS. light</b>	<b>Operation</b>
-32 deg.C (-25 deg.F) and below	ON	Neutral only
-31 deg.C (-24 deg.F) to -7 deg.C (+20 deg.F)	OFF	Neutral, First, Second, or Reverse
-7 deg.C (20 deg.F) and above	OFF	Full operation in all gears

### **USING THE ENGINE TO SLOW THE VEHICLE**

#### **AT 545**

To use the engine as a braking force, shift the range selector to the next lower range. If the vehicle is exceeding the maximum speed for a lower gear, use the service brakes to slow the vehicle to an acceptable speed where the transmission may be downshifted safely.

An automatic, compared to a manual, shift transmission has a longer "coast down" time. Until you are accustomed to this characteristic, you may need to manually downshift to reduce speed.

With a little experience in driving the automatic, you will learn to decelerate a bit sooner, or brake until automatic downshifts occur. This will reduce the need for manual downshifting.

#### **MD 3060**

To use the engine as a braking force, select the next lower gear. If the vehicle is exceeding the maximum speed for this gear, use the service brakes to slow the vehicle. When a lower speed is reached, the ECU will downshift automatically the transmission. Engine braking provides good speed control for going down grades. When the vehicle is heavily loaded, or the grade is steep, it may be desirable to preselect a lower gear prior to the grade. If engine speed is exceeded, the transmission will upshift automatically to prevent damage to the engine.

### **TRANSMISSION OIL TEMPERATURE**

The transmission oil temperature is indicated in some vehicles by a gauge specifically designed for this purpose and in some vehicles by the engine coolant temperature indicator. Extended operations at low vehicle speeds with the engine at full throttle can cause excessively high oil temperatures in the transmission. These temperatures may tend to overheat the engine cooling system as well as cause possible transmission damage.

If excessive temperature is indicated by the engine coolant temperature gauge. Stop the vehicle and check the cooling system. If the cooling system appears to be functioning properly, shift to neutral and accelerate the engine to 1200-1500 RPM. This should reduce the sump temperature to operating level within two or three minutes. If high temperature persists, stop the engine and have the overheating condition investigated by service personnel.

If excessive temperature is indicated by the transmission oil temperature gauge, check the oil level in transmission. (Refer to the Oil Check Procedure in your Allison Transmission operators manual). Stop the vehicle and shift to neutral. Accelerate the engine to 1200-1500 RPM. The temperature should return to normal within two or three minutes before the vehicle resumes operation. Normal temperature for both on and off-highway operation is 160-200 degrees F. Oil temperature should never exceed 250 degrees F. In units equipped with the MD 3060 transmission, if the sump oil temperature reaches 250 degrees F, the ECU will

inhibit operation in the higher gears and turn on the "OIL TEMP" light which is located on the shifter cover.

If high temperature in either engine or transmission persists, stop the engine and have the overheating conditions investigated by maintenance personnel.

**CAUTION: The engine should never be operated for more than 30 seconds at full throttle with the transmission in gear and the vehicle not moving. Prolonged operation of this type will cause the transmission oil temperature to become excessively high and will result in severe overheat damage to the transmission.**

If the transmission overheats during normal operation, check the oil level in the transmission.

### **TRANSMISSION BREATHER**

The transmission has a self-contained breather near the cooler line ports. Care should be exercised to avoid plugging this breather with paint, undercoating or any other material. The breather provides a passage for normal expansion and contraction of air and fluid within the transmission. A small amount of oil mist comes out of the breather during normal operation. If an excessive amount of oil is found in this area, the cause should be investigated.

## **HYDRAULIC BRAKES**

Bendix hydraulic disc brakes are standard on all body models.

The hydraulic brakes have the Bendix Maxi Power Booster dual hydraulic brake system. The system has a two-compartment reservoir mounted on the floor behind the driver. The Hydro-Max Booster is a hydraulic assist system using a hydraulic power steering pump. The hydraulic power steering pump is gear driven by the engine. There is an electrical back up power assist in the event of a malfunction in the hydraulic power pump system or loss of engine power. The battery provides the reserve power for the electrical back up power assist.

**CAUTION: Hydraulic Brake Systems are power assisted. Braking capacity is reduced without engine assist. Do not move bus with dead engine.**

The electric power back up pump will operate whenever the engine is not operating and the key switch is in either the **ON** or **START** position or when the key is in the **OFF** position and the brake pedal is depressed.

Test daily by feeling for the electric motor operation while applying the brakes with engine not operating, or when the key switch is in the **ON** or **START** positions and the engine is not operating. The pedal will initially be hard to push, and then the pedal will be softer to push as the electric motor starts.

**WARNING: Do not drive the bus when the electrical back up pump does not operate. In the case of a loss of a power assist, there will be reduced brake capacity without the electrical backup.**

### **DUAL BRAKE SYSTEM**

The dual brake system allows the driver reasonable brake capacity in case either the front or the rear brake circuit fails.

**CAUTION: When one circuit of the dual system fails, the following conditions will exist.**

1. Bus stopping distance will increase. Drive the bus only with extreme caution. **Service immediately!**
2. The brake pedal will be softer to push.
3. The brake pedal will travel further, even as far as the floorboard. These conditions exist because only one axle will be stopping the bus.

## MAINTENANCE

The Bendix disc brakes self-adjust for lining wear. Brake fluid in the reservoir located behind the driver's seat must be maintained to the correct level. As the brake linings wear, fluid from the reservoir will displace the lining thickness loss. Be sure to use only brake fluid in the reservoir behind the driver's seat.

The power steering reservoir is located behind the front grille access panel on the driver's side. The power steering fluid serves the power steering gear-driven pump, power steering gear and Bendix Hydro-max booster.

**CAUTION: Put only brake fluid in the brake fluid reservoir and power steering fluid in the power steering system. Failure to use the proper fluids could result in loss of braking or steering.**

## BRAKE WARNING SYSTEM

The brake warning system includes a buzzer and a dash mounted red light labelled **BRAKE**. The light and buzzer will operate as a result of the following:

1. Engine is running, brakes not applied with a loss of electrical power to the electric back up pump motor.
2. Engine is running, brakes not applied, with a loss of power assist from the power steering pump.
3. Engine is running, brakes are applied and either the front or rear section of the system has failed. The backup pump, buzzer and light will remain on even after the brake pedal has been released.
4. Engine is not running, brakes not applied, but ignition key is **ON**. This condition should happen every time the driver starts the bus. The bus should not be driven if the backup pump system is not working. The backup system should go off when the engine starts.
5. Engine is not running, brakes are applied, ignition is in **ON** or **START** position. This is a method for checking that the back-up pump system is not working. **NOTE: With engine not running and ignition OFF, a depressed brake pedal will cause the backup to run with no light and buzzer.** The back-up system should go off when the pedal is released. Without the assist of the power steering pump and without the assist of the backup pump, the master cylinder will allow the brakes to be applied. However, brake capacity will be very limited and the bus should not be driven under these conditions.

## PARKING BRAKE (HYDRAULIC BRAKES)

The parking brake is designed to hold the loaded bus up to a 20% grade. The parking brake is not to be used as a normal service brake, but can be used to help stop in an emergency situation.

When the parking brake is applied, and the ignition switch is **ON**, a dash-mounted yellow light labelled **PARK** will warn the driver that the brake is applied. The bus should not be driven when the parking brake is applied. Driving the bus when the parking brake is applied will prematurely wear the parking brake or damage other drive train components.

**WARNING: Improper adjustment of the parking brake can significantly reduce the holding ability of the parking brake system. This could result in the vehicle's moving when unattended.**

**CAUTION: The parking brake is designed to hold on the above mentioned grade on a clean, dry and smooth road surface. Parking on wet, ice or snow covered grades is not recommended. Chocking of wheel(s) is recommended when parking on any grade.**

**WARNING: Extreme caution should be exercised when the drive shaft is removed on a unit equipped with hydraulic brakes. The parking brake becomes inoperative when the drive shaft is disconnected. Do not leave the bus unattended until appropriate measures have been taken to prevent vehicle movement.**



The parking brake is adjusted by turning the knob on the parking brake lever. The knob is held in place with a set screw. The knob can be adjusted when the parking brake is released. When the parking brake is properly adjusted, the lever will snap firmly into place. Lever effort will be 80-100 pounds.

Extreme caution should be exercised when the drive shaft is removed on a unit equipped with hydraulic brakes. The parking brake becomes inoperative when the drive shaft is disconnected. Do not leave the bus unattended until appropriate measures have been taken to prevent vehicle movement.

## **AIR BRAKES**

---

A coach equipped with a dual air brake system consists of separate complete systems for the front and rear service brakes. A separate reservoir and air gauge is provided for each of these systems. A dual treadle valve is provided for operating the service brake system. In addition to providing excellent service brake performance, this dual brake system is equipped with safety features which allow the driver to use the emergency stopping system through the service brake treadle valve. In the event there is a failure in the air reserve for the front brakes, the rear service brakes can still be applied using the treadle valve, since the two service brake systems operate independently of each other. If there is a failure in the air reserve for the rear service brake system, the front service brakes and the rear spring brakes can be applied through the treadle valve. This allows the operator to use a normal method of braking during an emergency situation. However, in the case of an air reserve failure, the low air pressure warning buzzer will sound and warning light illuminated, giving an indication that trouble is evident and the respective air gauge located on the dash will indicate which system has lost air pressure. The coach must not be operated under those conditions, but repaired before continuing operation.

The rear spring brakes can also be controlled by a dash-mounted valve located on the lower portion of the instrument panel. These spring brakes cannot be fully released until the air reserve pressure is above 60 PSI. These brakes are in the released position when the control valve is pushed in, and in the applied position when the control valve is out. In the event there is a loss in air pressure, the valve will automatically move to the brake applied position and cannot be released until the air reserve pressure has been replenished.

### **AIR BRAKE ADJUSTMENT**

1. Raise the tire off the floor (**NOTE:** Install jack under the axle, not under the bumper.)
2. Turn the tire and adjust the brake slack adjuster until the brake shoes are tight against the brake drum.
3. Back off the slack adjuster until wheel rotates freely (very little drag).
4. Apply maximum brake application (100 psi +) and check brake chamber push rod travel. Readjust, if travel is greater than 1 1/4 inches.

### **FUEL STOP SOLENOID (AIR BRAKES ONLY)**

The bracket assembly, mounting, fuel stop solenoid is the on-off fuel flow control for the air brake TCFE Cummins 5.9 powered unit. The solenoid requires 12 volts to energize which allows fuel flow. Lubricate the pivot points with light duty engine oil. Clean the solenoid and linkage periodically. If service is required, assemble and adjust per drawing #1530435. Found with the vendor maintenance documents supplied per order.

### **PARKING**

Use the dash mounted valve to apply the rear spring brake when parking the coach. When the parking brake is applied, and the ignition switch is **ON**, a dash-mounted yellow light labelled **PARK** will warn the driver that the brake is applied.



**CAUTION: Do not attempt to move bus before spring brakes are released.**

## DRAINING AIR TANKS

Condensation must be drained from all air tanks daily. To drain tanks properly, leave cocks open until all air escapes and draining stops. **NOTE:** Daily draining is not required on units equipped with automatic drain valve or an air dryer. The air dryer removes water, oil and other contaminants before they reach the wet tank. The automatic drain valve contains a reservoir to collect condensation in the air brake system which ejects during the on-off cycle of the compressor. On valves with heating elements, freeze up protection is operational when the ignition is turned on.

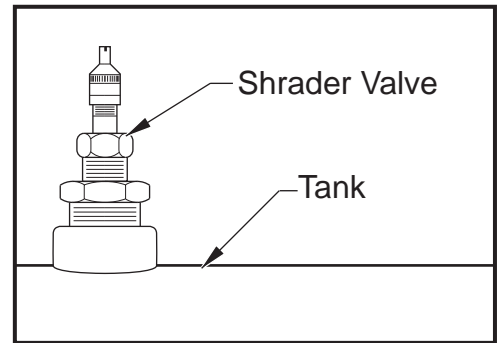

## SHRADER VALVE

The coach is equipped with a Schrader valve which is located at the end of the wet tank. It allows the air brake reservoir to be charged with a common type air hose normally used by service stations and garages. Charging this system in this manner is only a means of providing air pressure for the air brake system with an inoperable air compressor or without cranking the engine and should only be used for moving the coach while servicing or in case of emergency.

## MGM SERVICE AND PARKING BRAKE

**Releasing Spring Brake Manually:** If air pressure fails in the piston chamber, the power spring applies the brakes and, unless pressure can be re-established, the service brakes must be released as follows in order to move the coach.

**WARNING: Do not release spring brake until coach is secured by wheel chocks or tow vehicle. Failure to do so may result in bodily injury or property damage.**

Remove the release stud tool and nut from the carrying pocket on the brake chamber assembly. Remove the access plug from the end of the spring chamber. Insert the release stud through the opening in the chamber and into the spring pressure plate. Turn the release stud one-fourth (1/4) turn to engage the stud tangs with the slot in the pressure plate. Keep the stud engaged and install the nut on the release stud. Tighten the nut until the spring is fully caged and the brakes are released. Do not loosen or remove the release stud and nut unless the brake chamber is completely assembled and is securely clamped. When air pressure is restored, remove the release stud and install in carrying pocket.

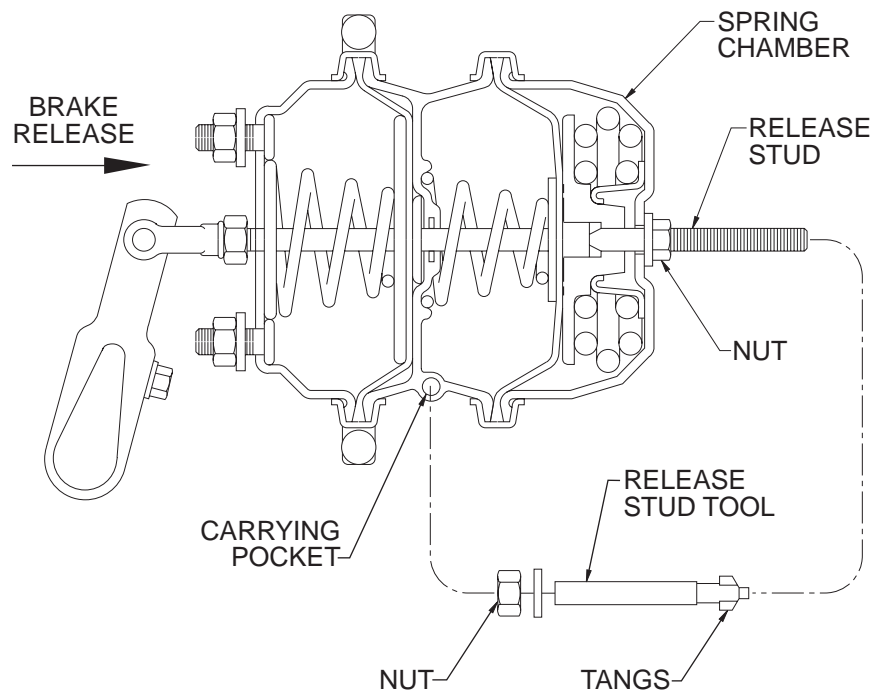

# DOOR/BRAKE INTERLOCK

## (If so equipped)

The door/brake interlock includes a 12 VDC power unit with integral pressure switches, a single actuator (displacing 2.9 cubic inches of system fluid) and an electronic control module. The operator interface of the electronic control module consist of an on/off switch, audible alarm and amber and green system indicator lights located at the switch panel to the left of the driver. The maximum system pressure control is factory set.

The door/brake interlock has an added feature in that it can also be used as a supplemental brake locking device.

The door/brake interlock will repressurize brake system and sound audible alarm if pressure drops below required system pressure. If audible alarm sounds repeatedly, a small leak and/or air is present in the door/brake interlock or the vehicle brake system.

## PRINCIPLES OF OPERATION

The door/brake interlock is armed when vehicle ignition is on. A switch contact closure will activate the door/brake interlock when door is opened. At that point the door/brake interlock utilizes existing service brake system to apply brakes.

## LOCK SYSTEM

The door/brake interlock is also a SUPPLEMENTAL safety device and is NOT to be used in place of original equipment parking brake. When used with existing vehicle parking brake the door/brake interlock uses a portion of the vehicle's hydraulic service brake system to provide additional brake holding action.

**WARNING: If a system leak develops, discontinue use of the Door/Brake Interlock until the cause of the malfunction is diagnosed and corrected**

**WARNING: Brake lock and warning circuits are disabled if battery power is lost or disconnected.**

**NOTE:** The following are decals along with WARNINGS located forward of the switch panel below the driver's side window.

Read Warnings and Operating Instructions prior to using.



**690 Brake Lock**

**TO LOCK:**

1. Set parking brake
2. Move lock switch to ON position

**TO RELEASE:**

1. Move lock switch to OFF position
2. Release parking brake

**WARNING**

Serious injury or death can occur if these instructions are not followed.



**PREVENT ROLLAWAY**

Vehicle equipped with Brake Lock System. Operator must read and understand operating instructions before using vehicle. Brakes will release if ignition is turned off when Brake Lock is remotely activated. Do not use Brake Lock in place of original equipment parking brake. Always set parking brake and use wheel chocks and outriggers with Brake Lock. Do not use Brake Lock for overnight or prolonged parking. Release Brake Lock before moving vehicle. Brake Lock and warning circuit are disabled if battery power is lost or disconnected.

**WARNING**

Serious injury or death can occur if these instructions are not followed. Opening vehicle service door causes brakes to be applied. Vehicle equipped with Door/Brake Interlock. Operator must read and understand operating instructions before using vehicle. Brakes will release if ignition is turned off when Door/Brake is remotely activated. Do not use Door/Brake for overnight or prolonged parking. Close vehicle service door before moving vehicle. Door/Brake and warning circuit are disabled if battery power is lost or disconnected.

# HYDRAULIC SYSTEM - TROUBLESHOOTING

---

1. Hydraulic fan will not run.
  - A. Check hydraulic oil level in reservoir. (Sight glass)
  - B. Check fan motor for free rotation, fan motor should rotate freely. If not rebuild or replace fan motor.

**CAUTION: Engine should be shut off when checking fan motor for free rotation.**

- C. Disconnect wires from relief valve solenoid or temperature control switch, and start engine. If fan runs with wire disconnected, the temperature control switch is at fault. Replace switch. If fan does not run with wire disconnected, the solenoid valve may be at fault. Repair or replace solenoid valve. If this does not correct the problem proceed with the following steps.
- D. With hydraulic system at normal operating temperature check pump output pressure to specifications below. Check pressure with wires disconnected from relief valve solenoid, or temperature control switch.

**Note:** A pressure tap can be installed at port marked "PR" on the relief valve.

ENGINE	PUMP PRESSURE (PSI)	ENGINE RPM	FAN RPM
5.9 Cummins	100-300	800	200
	2000	2500	1900
8.3 Cummins	2450	2400	1950

- E. If pressure is low, adjust the pressure relief adjustment screw by loosening the jam nut and turning the adjustment screw clockwise to increase pressure. If the pressure comes up to specifications, and the fan speed doesn't, the fan motor has excessive internal leakage and is at fault. Repair or replace fan motor. If specified pressure is obtained, the relief valve is at fault. Repair or replace relief valve.
- F. If after adjusting the pressure relief screw the pressure does not come up to specification, the pump may be at fault, repair or replace pump.

**NOTE:** If pump is faulty it is also likely the power steering will show signs of low pressure.

2. Fan motor runs continuously.
  - A. Check for 12 volts at the relief valve solenoid. Solenoid will not operate properly with less than 12 volts.
  - B. If check shows 12 volts at solenoid, solenoid or solenoid valve may be faulty. Repair or replace solenoid or solenoid valve.
  - C. If check shows no voltage at solenoid, check voltage supply at temperature control switch. If check shows 12 volts at temperature control switch, switch is at fault, replace switch. If check shows no voltage, check circuit breaker and all connections, short in circuit or open circuit.
3. Fan motor runs under speed.
  - A. Check engine speed at idle and full RPM.
  - B. See Steps 1-D, thru 1-F.
4. Shaft seal leak on pump is recognized by excessive addition of hydraulic oil, or in the Cummins 5.9T, and overfilled condition of the engine crankcase. Replace shaft seal or pump. Change engine oil.

## COOLING SYSTEM

---

**CAUTION: Use extreme care when removing a radiator pressure-control cap. The sudden release of pressure from a heated cooling system can result in a loss of coolant and possible personal injury (scalding) from the hot liquid or steam.**

Coolant should be drained and replaced every 2 years. See individual Quick Reference Maintenance Chart for complete guidelines for each engine.

On vehicles used in stop-and-go service, such as the TC, engine hoses deteriorate more rapidly; therefore it is important to inspect all such hoses frequently. Hoses which are worn, chafed, hardened or cracked must be replaced before a leak develops. On an age hardened hose, retightening a worm screw clamp will not stop connection leaks, and further indicates that the hose needs replacement. It is also important not to over-tighten clamps as this can damage the hose, or distort the tubing connector. When replacing a hose, the clamp should be torqued to 45 inch lbs. When checking a hose clamp, clamps should be torqued to a minimum of 34 inch lbs.

## FAN CLUTCH

---

### OPERATION

The Corsair Electromagnetic Fan Clutch is activated by 12 VDC from the vehicle electrical system. Bolted to the front of the engine, the fan gets power from belts the usual way. A separate control functions to turn the fan on and off as dictated by operating conditions. It operates by connecting 12 VDC to the magnets coil to engage the clutch; breaking the 12 volt circuit to disengage the clutch.

An increase of the engine coolant temperature above a preset limit causes a normally open thermal switch in the engine cooling system to close, "Close-on-Rise" at the present temperature.

A manual switch can also be added to the switch panel. This switch connection is parallel with the temperature switch allowing you to turn the fan on anytime.

### FAN CLUTCH WIRING HARNESS

Closure of the sensor switch or of the manual switch completes the 12 VDC circuit to ground. When the circuit is completed, 12 VDC flows to the coil of the electromagnet, fixing the fan hub to the belt pulley. As long as any switch is closed, the fan turns.

When the switch opens or power is interrupted for any reason, the coil loses power and the magnetic field collapses, releasing the fan hub from the drive pulley. As the field collapses, polarity across the diode reverses, making a low-resistance circuit to ground, protecting switch contacts. If the diode fails or there is some other break in the diode circuit, there is likely to be arcing damage in the opening switch.

### TROUBLE SHOOTING

If clutch fails to operate with engine temperature over 205 degrees F., check the temperature sensing device first, check the wiring and terminals, then using a jumper wire touch the two terminals of the temperature switch, if the clutch clicks in when you jump these terminals, the temperature sensing device has failed. (The engine temperature must be over 205 degrees F. with the clutch still not engaged during the test.) If this is the case, temporarily connect the two terminals and this will by-pass the temperature sensing device causing the fan to run all the time. Install a new temperature sensing device as soon as possible.

## TC PITMAN ARM

If it becomes necessary to remove the pitman arm from the steering gear, it is possible with the gear still on the vehicle. The pitman arm may be removed as follows:

1. Remove the front of the drag rod from the pitman arm.
2. Rotate the steering gear so that the pitman arm nut and bolt are accessible with a socket and extension for a ratchet wrench.
3. Locate and mark pitman arm and steering gear output shaft with a scribe or felt marker before removal of pitman arm to insure reinstallation in the same location.
4. After removing the pitman arm nut and bolt, the pitman arm boss must be spread in order to loosen the pitman arm for removal from the shaft. Spreading the boss may be accomplished by using the correct size Allen wrench, a chisel or a pitman arm spreader.
5. When the boss is spread, slide the pitman arm off the steering gear shaft.
6. If vendor supplied mark does not line up with mark on the steering gear output shaft; cross out vendor supplied mark on pitman arm with a small chisel or punch and hammer.
7. Make a new mark to line up with mark on the steering gear output shaft.

If the same pitman arm is to be reinstalled onto the steering gear, clean the end of the steering gear shaft and the outside of the pitman arm so that the alignment marks on each are visible.

The pitman arm may be installed as follows:

1. Rotate the output shaft on the steering gear so that the mark on the output shaft is perpendicular to the input shaft.
2. On the TCFE install the pitman arm on the steering gear output shaft (1) spline to the rear from parallel to the input shaft so that the marks on the splines align.
3. Install the pitman arm clamp bolt, nut and hardened flatwasher on the nut side. Be sure there is no spreading wedge left in the pitman arm boss before torquing the pitman arm clamp bolt to 280-325 ft. lbs.
4. Reinstall the drag rod onto the pitman arm. (Torque 120-170 ft. lbs.)

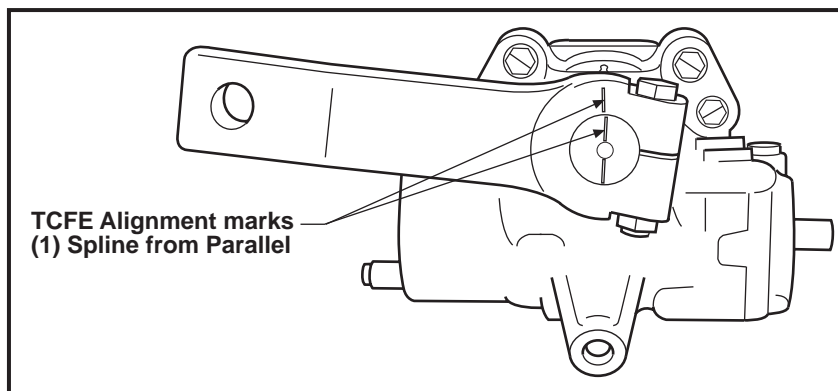

# WHEELBEARING ADJUSTMENT

---

## FRONT AXLE

1. Assemble the bearings and hub onto the axle spindle.
2. Install the wheel bearing adjusting nut. Torque the adjusting nut to 50 ft. lbs., while rotating the hub and drum in both directions, so all bearing surfaces are in contact, then back off 1/6 to 1/4 turn to allow the wheel to rotate freely.
3. Install the nut lock.  
**NOTE:** Rotate the bearing nut slightly for alignment.
4. Install the jam nut and torque to 125-150 ft. lbs.
5. Bend the lockwasher over the jam nut.
6. Check for excessive bearing end play; not to exceed .010.
7. Install the hub cap gasket and the hub cap. Torque the mounting bolts to 11-13 ft. lbs.

## REAR AXLE

### SPICER REAR AXLE F170-S, J190-S, J210-S AND J230-SB

1. Assemble the bearings and hub onto the axle spindle.
2. Install the dowelled wheel bearing adjustment nut. Torque the adjusting nut to 50 ft. lbs., while rotating wheel in both directions, so all bearing surfaces are in contact, then back off 1/6 to 1/4 turn to allow wheel to rotate freely.
3. Install the nut lock.  
**NOTE:** Rotate the bearing nut slightly for alignment.
4. Install outer jam nut and torque to 250-275 ft.-lbs.
5. Check for excessive bearing end play; not to exceed .010.
6. Install the axle shaft gasket over the studs in the hub.
7. Slide the axle shaft into place, over the studs in the hub.
8. F170-S:  
Torque Nylok nuts to 95-115 ft.-lbs.  
Torque steel crimp lock nuts to 115-125 ft.-lbs.  
J190-S, J210-S, J230-SB  
Torque Nylok nuts to 217-240 ft.-lbs.  
Torque steel crimp lock nuts to 275-320 ft.-lbs.

## REAR AXLE VENT

---

All drive axles have a vent on the top of the axle housing that allows the axle to breathe as the axle temperature changes. The vent must remain open to prevent seal failures. Note that it is normal for the vent to ooze some lubricant.

# SUSPENSION CLEARANCE

The allowable side-to-side movement between spring leaf and shackle or between shackle and spring hanger is 1/4". The allowable movement between spring torque leaf bushing tube and the spring hanger is 1/4". Total movement may be determined by inserting a 12" to 16" bar through the spring hanger bracket and the torque leaf at the spring eye, shifting the torque leaf side to side and up and down. **DO NOT** use a bar over 16" long to prevent damage to spring hanger or spring.

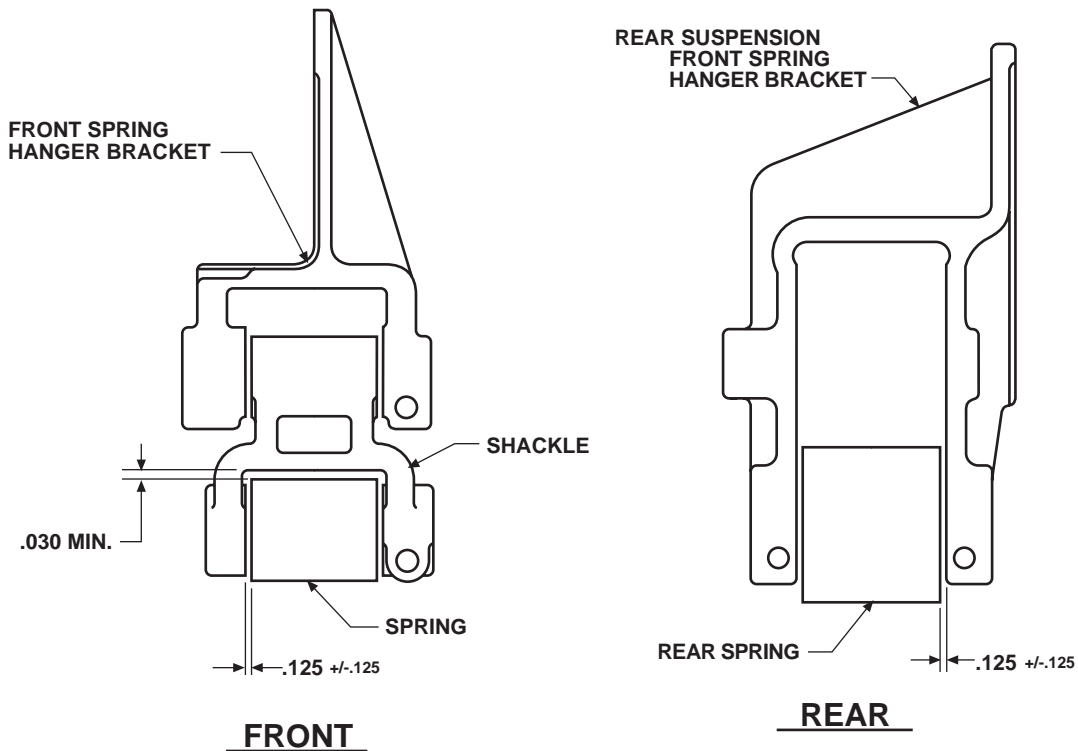

# SCHEDULED MAINTENANCE

## MONTHLY OR 1,000 MILES

- Grease safety barrier latch on Braun wheelchair lift.
- Lubricate roof hatch weatherseals & lock mechanisms.
- Inspect all emergency equipment mounting fasteners.
- Lubricate window latches and slides.
- Lubricate hinge pin on entrance doors.
- Lubricate pivot points on outward opening door.
- Check/adjust roller bracket and control rod bracket on jackknife door.
- Check/adjust air pressure in power jackknife door.
- Inspect outer fasteners and lubricate electric stop arms.
- Inspect seat frames for secure attachment to the floor and wall.
- Lubricate rear emergency door positive hold open hinge.



### MONTHLY OR 3,000 MILES

- Check fuel system (Drain fuel and contaminants, if required).
- Check battery water level.
- Inspect brake chambers.

### 3 MONTHS OR 5,000 MILES

- Inspect fire extinguisher to see if fully charged.
- Check first aid kits to see if fully equipped.
- Oil all hinges and window latches for ease of operation.
- Lubricate all window channels with silicone or graphite.
- There is one drain hole in each floor section under windows. Be sure hole is clear of debris so any water may escape.
- Clean all rubber door seals and lubricate with rubber lubricant.
- All rear and side emergency door latch slide bars to be lubricated with light grease to reduce friction.
- Tighten all tie down bolts to 37-41 foot pounds torque at 1,000 miles, 2,000 miles, and quarterly thereafter.
- Change main heater air filter (depending on operating conditions).
- Grease emergency door hinges.
- Check seat cushion clamps.
- Inspect mounting bolts on body tie down.
- Inspect mounting fasteners and upholstery on seats.
- Lubricate bridge plate hinge and pivot on Collins wheelchair lift.
- Clean and lubricate fold cam slot, platform cam slots and handrail V-block on Collins wheelchair lift.
- Check fluid level in Collins wheelchair lift.
- Lubricate hinge and latch mechanisms on access doors.
- Check internal fasteners on electric stop arms.
- Lubricate entrance door vandal lock.
- Inspect heater valves to verify proper function.
- Change engine oil and oil filter.
- Inspect fuel cap, tank and fuel lines.
- Inspect engine fuel tank vents.
- Inspect engine air filter, replace if required.
- Inspect driveshaft.
- Lubricate universal joint and slip joint.
- Lubricate clutch release bearing.
- Inspect accelerator system cable.
- Lubricate emergency brake linkage.
- Lubricate brake calipers.
- Clean and lubricate fuel stop solenoid.
- Lubricate brake camshaft, king pins, tie rod ends and slack adjusters.

### 3 MONTHS OR 24,000 MILES

- Inspect Bendix air dryer.
- Check for loose or disconnected electrical connections and damaged wiring.
- Check the vehicle brake warning system.
- Check the brake fluid level of the master cylinder reservoir.
- Check the hydro-max exterior and all connecting lines for fluid leakage.
- Check brake linkage and brake calipers.

## **6 MONTHS OR 6,000 MILES**

- Inspect exhaust system piping, joints for leaks, corrosion, etc. (See CHASSIS COMPONENT MAINTENANCE CHART)
- Check lubricant level in rear axle.
- Inspect rear axle vent.
- Clean and/or replace air compressor filters.
- Check power steering fluid level.
- Lubricate steering drag rod.
- Check single and double check valves.
- Lubricate spring pin.
- Inspect alternator.
- Clean battery posts.
- Disassemble and clean the air compressor governor and repair, as required.
- Lubricate entrance door vandal lock.
- Check/adjust emergency door vandal lock.
- Lubricate lock mechanism and door hinge on emergency door.
- Inspect destination sign for proper operation.
- Lubricate hinges and roller gears on destination signs.
- Check/adjust curtain on destination signs.
- Lubricate all working part joints on driver's seat using lithium-based grease (aerosol).
- Check/adjust door control rod on manual entrance doors.
- Clean and flush Anchorlok air dryer - Spring and Fall.
- Clean and lube treadle valve.
- Change engine fuel filter.

## **12 MONTHS OR 12,000 MILES**

- Complete Quarterly Maintenance Check List.
- Remove all seat cushions, thoroughly clean with upholstery cleaner and reinstall on a rotating basis.
- Adjust door control rod and closing mechanism to entrance doors.
- Bleed all air from heaters.
- Tighten all heater hose clamps.
- Check cylinder chains, hoses and wires on the Braun Wheelchair lift.
- Check heater hoses, motor wheels and fans on heaters.
- Clean heater core.
- Tighten heater hose clamps.
- Inspect power steering pump.
- Inspect steering gear.
- Lubricate steering column.
- Check front and rear suspension U-bolt torque.
- Check spring pin lock bolt.
- Check spring pin and bushing wear.
- Inspect suspension system and components.
- Inspect shocks.
- Inspect suspension hanger bracket to frame fastener torque.
- Inspect quick starting aid.
- Inspect engine block heaters.
- Inspect radiator hoses.
- Pressure test engine cooling system.
- Check heater panels and housing.

## 12 MONTHS OR 24,000 MILES

- Check air tank pop-off valves.
- Change automatic transmission filter.
- Change internal automatic transmission filter.
- Inspect automatic transmission vent.
- Change power steering reservoir filter.
- Change lubricant in rear axle.

## 24 MONTHS OR 24,000 MILES

- Clean radiator and shutters.
- Change thermostat.
- Clean relay valves, spring brake valves, parking brake valves, and quick release valves.
- Clean pressure protection valves.
- Inspect and clean Cyclo-Gard air dryer.
- Change coolant.

These check lists are suggested. They do not replace or supersede local or state required driver inspection procedure.

## MAINTENANCE SERVICE KEY

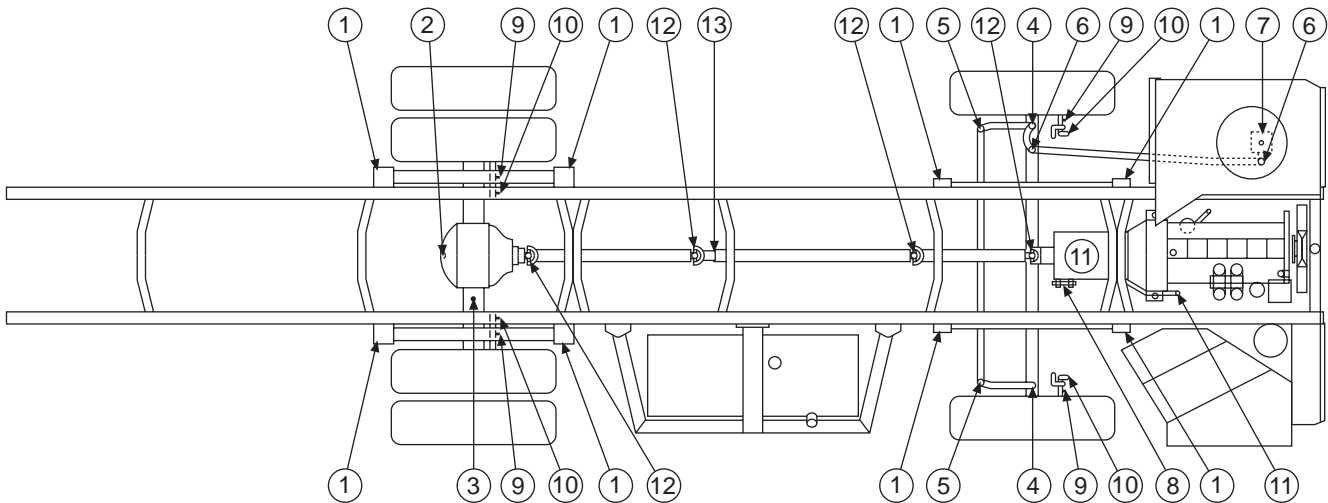

## TCFE MAINTENANCE SERVICE KEY

# QUICK REFERENCE MAINTENANCE CHARTS

**NOTE:** For engine service, operation and maintenance, see the Engine Operator's Manual supplied in the owner's packet provided with this vehicle.

## SUSPENSION MAINTENANCE CHART

Operation	Service Intervals *							Months / Miles Whichever Occurs First	
	1 / 3,000	3 / 5,000	3 / 24,000	6 / 6,000	6 / 10,000	12 / 12,000	12 / 24,000	24 / 24,000	
									*Service Intervals to be performed on a continuing basis. Example: 1 / 3,000 means every month or every 3,000 miles.
									<b>General Instructions</b>
<b>SPRING SUSPENSION</b>									
Check Front U-bolt Torque						●			Torque to 325 ft. / lbs.
Check Rear U-bolt Torque						●			Torque to 325 ft. / lbs.
Check Spring Pin Lock Bolt						●			Bolt, hardened flatwasher and locknut must be in position.
Check Spring Pin and Bushing Wear						●			Inspect by using a pry bar to apply pressure to the spring pin and bushing.
Lubricate Spring Pin				●					8 Fittings. Lubricate at first 1,000 miles and then at regular intervals. Use NLGI grade No. 2 Grease. See key No.1 page 82.
Inspect Suspension						●			Inspect all spring components for damage or misalignment.
Inspect Shocks						●			Inspect for leaks.
Check Hanger Bracket Fastener Torque						●			Torque to 80 +/- 5 ft. lbs.
<b>NEWAY REAR AIR</b>									
Check U-bolt Torque						●			Torque to 350-375 ft. lbs.
Check Front Pivot Bolt						●			Torque to 600-625 ft. lbs.
Check Shock Mtg. Bolts						●			Torque to 100-125 ft. lbs.
Check Air Spring Fasteners						●			1/2" Torque to 30-35 ft. lbs. 3/4" Torque to 30-35 ft. lbs.
Inspect Shocks						●			Inspect for leaks.
Check Ride Height						●			4.875 inches between bottom of frame rail and top of axle.
<b>NEWAY FRONT AIR</b>									
Check Front Axle to Suspension Fasteners						●			Torque to 260-280 ft. lbs.
Check Front Pivot Bolts						●			Torque to 460-480 ft. lbs.
Check Shock Mtg. Bolts						●			Torque to 100-125 ft. lbs.
Check Air Spring Fasteners						●			1/2" Torque to 30-35 ft. lbs. 3/4" Torque to 30-35 ft. lbs.
Check Shocks						●			Inspect for leaks.
Check Height of Suspension						●			9.25 inches from top of axle pad to bottom of frame rail.

# AXLE MAINTENANCE CHART

Operation	Service Intervals *							Months / Miles Whichever Occurs First	
	1 / 3,000	3 / 5,000	3 / 24,000	6 / 6,000	6 / 10,000	12 / 12,000	12 / 24,000	24 / 24,000	
*Service Intervals to be performed on a continuing basis. Example: 1 / 3,000 means every month or every 3,000 miles.									
<b>General Instructions</b>									
<b>REAR AXLE</b>									
Check Lubricant				●					See Spicer Maintenance Manuals on F170S, J190S, J210S, & J230SB Axles. Keep oil to level of filler plug. Drain & refill at first 1,000 to 3,000 miles and then at recommended intervals. Check level testing plug on rear of axle bowl. See vendor reference for recommended lubricant. See key No.2 page 82.
Change Lubricant							●		
Inspect Vent				●					See page 78. See key No.3 page 82.
Wheel Bearing Adjustment	As Required								See page 78.
<b>FRONT AXLE</b>									
Lubricate King Pin		●							4 Fittings. Use NLGI Grade No. 2 Grease. See key No.4 page 82.
Lubricate Tie Rod		●							2 Fittings. Use NLGI Grade No. 2 Grease. See key No.5 page 82.
Wheel Bearing Adjustment	As Required								See page 78.
Inspect Alignment and Component Wear	If Tire Wear Indicates								Caster 3° +/- 1° positive. Camber 0° +/- 7/16° RH & LH. (Toe-In 0 to 1/16") Spring and Neway Air suspensions. Axle settings are the same for both radial and bias ply tires.
<b>FRONT AXLE STEERING</b>									
Check Hydraulic Reservoir Fluid Level				●					Check level sight glass. Use Dexron II.
Change Reservoir Filter							●		More frequent filter changes may be necessary in a dusty environment. BB filter #2108199.
Lubricate Drag Rod				●					2 Fittings. Use NLGI Grade No. 2 Grease. See key No.6 page 82.
Inspect Power Steering Pump						●			Check for leakage around the shaft or housing. If leak is evident (fluid oozing out), it should be corrected immediately.
Inspect Steering Gear						●			Check for leakage around the shaft or housing. If leak is evident (fluid oozing out), it should be corrected immediately. See key No.7 page 82.
Index Pitman Arm	If Arm is Removed								See page 77.
Lubricate Steering Column						●			Lubricate the slide. Access to slide is obtained by removing rubber boot. Use NLGI Grade No. 2 Grease.
Lubricate Steering Gear				●					See TRW Ross Steering Gear Manual. Grease fitting located on rear of gear. Use hand grease gun only. Use NLGI Grade No. 2 Grease. See key No.7 page 82.
<b>TIRES</b>									
Check Tires	Weekly								See page 52.

# BRAKE MAINTENANCE CHART

Operation	Service Intervals *								Months / Miles Whichever Occurs First
	1 / 3,000	3 / 5,000	3 / 24,000	6 / 6,000	6 / 10,000	12 / 12,000	12 / 24,000	24 / 24,000	*Service Intervals to be performed on a continuing basis. Example: 1 / 3,000 means every month or every 3,000 miles.
General Instructions									
<b>AIR BRAKE SYSTEM</b>									
Air Brake Operation									See page 72.
Clean & Replace Air Comp. Filters				●					See Bendix Air Brake Handbook. Bendix filter #243009. BB #1339993.
Clean Governor				●					See Bendix Air Brake Handbook. Disassemble all valves and lubricate at 100,000 miles.
Inspect Bendix Air Dryer			●						See Bendix Air Brake Handbook & Service Data sheet SD-08-04.
Inspect & Clean Cyclo-gard Air Dryer								●	See Cyclo-gard Air Dryer Form #313.
Clean Anchorlok Air Dryer Tank and Flush Drain Valve				●					See Anchorlok Air Dryer Service Instructions. Service in spring and fall.
Inspect Heated Reservoir Drain Valve									See Stark Expello Valve Form S-103. Maintenance-free no adjustment or cleaning necessary.
Drain Air Tanks	Daily-cold weather Weekly-warm weather								Drain condensatration.
Check Pop-Off Valves								●	See Bendix Air Brake Handbook. Disassemble all valves and lubricate at 100,000 miles.
Check Single & Double Check Valves				●					See Bendix Air Brake Handbook. Disassemble all valves and lubricate at 100,000 miles.
Clean & Lube Treadle Valve				●					See Bendix Air Brake Handbook. Disassemble all valves and lubricate at 100,000 miles.
Clean Relay Valves								●	See Bendix Air Brake Handbook. Disassemble all valves and lubricate at 100,000 miles.
Clean Spring Brake Valves								●	See Bendix Air Brake Handbook. Disassemble all valves and lubricate at 100,000 miles.
Clean Parking Brake Valve								●	See Bendix Air Brake Handbook. Disassemble all valves and lubricate at 100,000 miles.
Clean Quick Release Valves								●	See Bendix Air Brake Handbook. Disassemble all valves and lubricate at 100,000 miles.
Inspect Brake Chambers	●								See Bendix Air Brake Handbook.
Clean Pressure Protection Valves								●	See Bendix Air Brake Handbook. Disassemble all valves and lubricate at 100,000 miles.
<b>SHOE-TYPE BRAKES (AIR)</b>									
Brake Inspection and Adjustment	Weekly or as needed depending on application								See Rockwell Field Maintenance Manual No. 4 or See Eaton EB-31 Service Manual or See Eaton EB-32 Service Manual. Also see page 72.
Lube Parking Brake Linkage		●							4 Fittings. See page 72 & See key No.8 page 82. Use NLGI Grade No.2 Grease.
Adjust Parking Brake	●								See page 73.
Lubricate Brake Camshaft		●							4 Fittings. Use NLGI Grade No. 2 Grease. See key No.9 page 82.
Lube Brake Slack Adjusters		●							4 Fittings. Use NLGI Grade No. 1 Grease. (Special Stopmaster Grease) See key No.10.
<b>HYDRAULIC BRAKES (DISC)</b>									
Hydraulic Brake Operation									See page 70.
Check Brake Fluid Level of Master Cylinder Reservoir.	●								Replenish, if necessary. Fluid BB #0607671; Vendor #218; or Wagner FL 10341.
Check the Hydro-Max Exterior & Connecting Lines for Leaks.			●						Replenish, if necessary. Fluid BB #0607671; Vendor #218; or Wagner FL 10341.
Check for Loose or Disconnected Electrical Connections and Damaged Wiring.			●						
Check Brake Linkage			●						Do Not Lubricate.
Check Brake Calipers for Fluid Leaks			●						No adjustment Required.
Lubricate Brake Calipers		●							Lubricate each time caliper is removed for pad change or repair.

# CHASSIS COMPONENT MAINTENANCE CHART

Operation	Service Intervals *								Months / Miles Whichever Occurs First
	1 / 3,000	3 / 5,000	3 / 24,000	6 / 6,000	6 / 10,000	12 / 12,000	12 / 24,000	24 / 24,000	*Service Intervals to be performed on a continuing basis. Example: 1 / 3,000 means every month or every 3,000 miles.
General Instructions									
<b>ACCELERATOR SYSTEM</b>									
Inspect Cable	●								Check cable for proper connection, cracking, abrasion or deterioration. No lubrication required.
Clean & Lube Treadle Valve	●								See Williams Control Service Bulletin S-051. Refer to the diagram Air Throttle Control, supplied with vendor maintenance documents for schematic of air throttle.
Clean & Lube Slave Cylinder	●								See Williams Control Service Bulletin SB388UIC3D.
<b>ELECTRICAL SYSTEM</b>									
Check Battery Water Level	●								Use distilled water to fill.
Check Battery Posts				●					Clean more often if corrosion appears. Use heavy grease to help prevent corrosion.
Inspect Alternator				●					See Delco-Remy Service Bulletin 1G-266
Inspect Quick Starting Aid						●			Check system for proper operation. Check wiring and tubing for proper connection and deterioration. Replace parts as necessary.
Inspect Engine Block Heaters						●			Check wiring and hoses for proper connection, cracking, abrasion and deterioration. Replace parts as necessary.
<b>EXHAUST SYSTEMS</b>									
Inspect Exhaust Piping and Joints				●					Inspect piping and joints for leakage, corrosion, etc. Replace clamps if joint is leaking. Clamps are not reusable. Reseal with exhaust sealant and install new clamp.
<b>AUTOMATIC TRANSMISSION</b>									
Check Fluid Level	Daily								See Allison Operators Manual. Use Dexron or Dexron II fluid. See key No.11 page 82.
Change Fluid								●	See Allison Operators Manual. Use Dexron or Dexron II fluid. See key No.11 page 82.
Change External Filter	1st 5,000 Miles then at Normal Oil Change Intervals								Filter located on RH side of engine block. Filter - AC 25011122 or PF 897
Change Internal Filter								●	Remove transmission fluid pan. Use vendor kit #23019201
Check Vent								●	See page 70.
Inspect Shift Cable								●	No lubrication required.
Adjust Shift Cable	As Required								See page 66.
<b>DRIVELINES</b>									
Inspect Driveshaft	●								See Spicer Service Manual.
Lubricate Universal Joint	●								See Spicer Service Manual. Use NLGI Grade No. 1 or 2 Grease. See key No.12 page 82.
Lubricate Slip Joint	●								See Spicer Service Manual. Use NLGI Grade No. 1 or 2 Grease. See key No.13 page 82.
Torque Capscrews & Bolts	If Damaged or Removed for Service								See Spicer Service Manual.
Straighten / Balance Angles and Phasing	If Damaged or Removed for Service								See Spicer Service Manual.

# BODY COMPONENT MAINTENANCE CHART

Operation	Service Intervals *							Months / Miles Whichever Occurs First	General Instructions
	1 / 1,000	3 / 5,000	3 / 24,000	6 / 6,000	6 / 10,000	12 / 12,000	12 / 24,000	24 / 24,000	
<b>OUTWARD OPENING DOOR</b>									
Adjust Door Linkage Rod									As Required Adjust door linkage rod for proper open/closed position.
<b>JACKKNIFE DOOR</b>									
Adjust Door Control Rod				●					Adjust door control rod for proper open & closed position. See page 32.
Adjust Roller Bracket	●								Adjust roller bracket for easier door operation. See page 32.
Adjust Control Rod Bracket	●								Adjust bracket to prevent pivot pin binding. See page 32.
Lubricate Hinge Pin	●								Lubricate each hinge lug. See page 32. Use LPS No. 1 lubricant.
<b>POWER JACKKNIFE DOOR</b>									
Lubricate Hinge	●								Lubricate hinge pin. Use LPS No. 1 lubricant.
Adjust Air Pressure & Switch	●								See page 33-34.
<b>AIR STOP ARM</b>									
Lubrication									No lubrication required.
Adjustment									As Required Adjust air pressure for proper opening and closing of stop arm.
<b>ELECTRIC STOP ARM</b>									
Lubrication	●								Lubricate breakaway hinge at four (4) pivot points. Use Tri-Flow™ (Dupont) lubricant.
Inspect Outer Fasteners	●								Check outer fasteners for tightness.
Inspect Internal Fasteners		●							Check inner fasteners for tightness.
<b>VANDAL LOCKS</b>									
Lubricate Entrance Door				●					Lubricate bushing & shaft in center at base of lock handle. See page 35. Use "Apply"™ lubricant.
Lubricate Entrance Door Key Lock		●							Spray lubricant into key lock. Use "Apply"™ lubricant.
Lubricate Sliding Bolt		●							Lubricate sliding bolt mechanism. Use LPS No. 1 lubricant.
Inspect & Adjust Emerg. Door		●							No lubrication and adjustment required.
<b>BUS BODY CARE</b>									
Wash									As required See page 36.
<b>EMERGENCY EXITS</b>									
Lubricate Lock Mechanisms				●					Spray lubricant into lock mechanism. Use Silicon spray.
Lubricate Roof Hatch	●								Spray silicon lubricant into lock mechanism. Work lock handle back & forth to insure smooth operation. See page 26. Use Silicon spray.
Lubricate Door Hinge				●					Spray lubricant into hinge lugs. Use LPS No. 1.
Lubricate Rear Emerg. Door Positive Hold Open Hinge	●								Grease with door closed. use low temp grease per ASTM D4950 GC-LB Grade 2. -60 deg. to 350 deg. F. One fitting per hinge
<b>EMERGENCY EQUIPMENT</b>									
Inspect All Mounting Fasteners	●								Inspect all emergency equipment mounting bracket fasteners to insure tightness.
<b>DESTINATION SIGNS</b>									
Lubricate Hinges				●					Lubricate all hinge lugs. Use lightweight lubricating oil.
Lubricate Roller Gears				●					Lubricate roller gears where required. Use lightweight grease such as (White Lube).
Check & Adjust Curtain				●					See page 11-12.
Replace Bulb									As Required
<b>WINDOWS</b>									
Lubricate Latch	●								Spray lubricant into window latch mechanism. Use Silicon spray.
Lubricate Window Slides	●								Spray lubricant into sliding frame of window. Use Silicon spray.



# BODY COMPONENT MAINTENANCE CHART

Operation	Service Intervals *								Months / Miles Whichever Occurs First
	1 / 1,000	3 / 5,000	3 / 24,000	6 / 6,000	6 / 10,000	12 / 12,000	12 / 24,000	24 / 24,000	General Instructions
<b>HEATERS</b>									
Check Heater Hoses						●			Check hoses for kinks, cracks or other visible signs of damage. See page 41.
Clean Heater Coil & RH Front Heater Air Filter						●			Keep air flow passage free of dust & dirt by cleaning w/compressed air or vacuum & a soft bristle brush. Straighten damaged fins with a fin comb. See pages 38-41.
Check Motor Wheels & Fans						●			Check wheels and fans for obstructions or damage by running each fan alone, then listen and feeling for irregularity. Replace damaged wheels or fans to prevent vibratory damage.
Check Heater Panels & Housing						●			Fasteners which connect and retain structural & access panels should be checked and tightened as necessary.
Tighten Heater Hose Clamps	1st 1,000 Miles and Annually Thereafter								Heater hose clamps are located at the underseat heater coil, behind the access door in the heater hose covering immediately forward of the left front wheelhousing & under the floor near right front and driver's heaters.
<b>BODY MOUNTING</b>									
Inspect Mounting Bolts	●								See page 31.
<b>MIRRORS</b>									
Adjust Mirrors	As required								Loosen adjusting nuts, make adjustment, then retighten nuts.
<b>SEATS</b>									
Inspect Mounting Fasteners	●								Tighten fasteners if required.
Inspect Cushion Attachments	Weekly								Tighten with Phillips-head screwdriver, if required.
Inspect Upholstery	●								Inspect for cuts, tears, wear and soiled areas.
Lubricate Driver's Seat			●						Apply lubricant to all working part joints. Use Aerosol Lithium base grease.
Inspect Seat Belts	Weekly								Inspect for torn or frayed areas.
Inspect Seat Belt Buckles	Weekly								Inspect for adjustability and proper operation.
Lubricate Seat Belt Buckles	As Required								Lubricate buckles to insure ease of operation. Use Graphite-type lubricant.
Clean Seat Belt Webbing	As Required								Clean using warm water and detergent solution.

# WHEELCHAIR LIFT MAINTENANCE CHART

Operation	Service Intervals *		Months / Miles Whichever Occurs First
	Months	Miles	General Instructions
<b>BRAUN</b>			
Grease Safety Barrier Latch	1	1,000	See Braun L205 Owner's Manual. Use light oil 30 weight or equivalent.
Lube Hinges and Pins	1 or 100 cycles	1,000	See Braun L205 Owner's Manual. Use light oil 30 weight or equivalent.
Check Cylinder Chains, Hoses and Wires	12	12,000	See Braun L205 Owner's Manual.
<b>COLLINS</b>			
Lube Bridge Plate Hinge and Pivot Points	3 or 600 cycles	5,000	See Collins (Mobile Tech) Maintenance & Service Manual. Use WD-40 lubricant.
Clean and Lube Fold Cam Slot, Platform Cam Slots and Handrail V-block	3 or 600 cycles	5,000	See Collins (Mobile Tech) Maintenance & Service Manual. Use #2 lithium grease.
Check Fluid Level	3 or 600 cycles	5,000	See Collins (Mobile Tech) Maintenance & Service Manual. Use aircraft hydraulic fluid H-5606.

Service Intervals \*

\*Service Intervals to be performed on a continuing basis.

Example: 1 / 3,000 means every month or every 3,000 miles.

# GENERAL DATA

---

## DIMENSIONS:

Headroom - 74" to 77"

Exterior height w/ AC - add 16"

Exterior height - approximately 118" to 121"

Exterior width - 96"

Interior width - 90 3/4"

## FLUID CAPACITIES

<u>ENGINE</u>	<u>Engine Crankcase Oil</u>		<u>Engine Coolant</u>	<u>Transmission Fluid</u>	
	<u>w/Filter</u>	<u>w/o Filter</u>		<u>Manual</u>	<u>Auto.</u>
Cummins 6BTA5.9	17 qts	15 qts	24.6 qts		20 qts.
Cummins 8.3 "C"	24 qts.	20 qts.	23.6 qts.	6.5 qts.	19 qts.
John Deere 8.1	32 qts.	30 qts.	38 qts.		20 qts.
			42 qts.		

## REAR AXLE FLUID CAPACITIES

Spicer F-170-S	23 pts.	Single Speed	Spicer J-190-S	31.5 pts.	Single Speed
Spicer J-210-S	31.5 pts.	Single Speed	Spicer J-230-SB	31.5 pts.	Single Speed
			Spicer M-190-T	35.0 pts	Two-Speed

## ENGINE OIL PRESSURE

Cummins 5.9TA

Cummins 8.3 "C"

John Deere 8.1

40-60 PSI @ 2500 RPM

40-50 PSI @ 2500 RPM

30-45 PSI Idle to Rated

# **ELECTRIC VEHICLE INFORMATION**

---

## **INTRODUCTION**

Blue Bird Corporation and Northrop Grumman Electronic Systems have developed the first purpose built all-electric school bus. This is a full size 72 passenger vehicle based on the popular TC chassis design. This portion of this manual is designed to assist the operator and maintenance personnel with their familiarization and operation of the valve regulated lead acid powered electric vehicle. It contains information peculiar to the Blue Bird electric school bus. Any procedures discussed herein for driving, charging, etc. shall not be applied to any vehicle other than those valve regulated lead acid powered vehicles.

**WARNING: The electrolyte in the vehicle batteries is an absorbed electrolyte glass mat, consisting of sulfuric acid. Sulfuric acid can cause severe burns. There is no means of gaining access to the inside of the battery. There is no liquid electrolyte and exposure can occur only if a battery is cut open and the internal cells are exposed. If you happen to get any electrolyte on your skin or in your eyes, flush the affected areas with large quantities of water for at least 15 minutes, and seek medical attention.**

**WARNING: The voltage of the battery packs is approximately 336 volts DC. Do not attempt to service the vehicle yourself. Initial service training will be provided and a separate service addendum will be provided. Failure to follow proper procedures can result in serious injury or death by electrocution.**

**WARNING: The batteries may produce potentially flammable and explosive gasses during charging that could accumulate to dangerous levels in non ventilated areas. Do not charge the vehicle in an enclosed area. Keep flames and sparks away from batteries. Just as you would do during "fueling" your personal vehicle, do not smoke when "fueling" (i.e. charging) the electric vehicle.**

**WARNING: Seat belt use is mandatory for the operator during vehicle operation.**

## **FUNCTIONAL DESCRIPTION**

The electric vehicle is different from any other vehicle you have ever driven. When driving this vehicle, you will notice the absence of noise typical of an internal combustion engine, whether it is gasoline, diesel or natural gas powered. There will also be an absence of the distinct shifting of gears that you can feel when driving a combustion engine vehicle equipped with an automatic transmission.

The traditional internal combustion engine parts are gone. There is no water-cooled, piston-driven engine. There is no clutch or transmission that shifts gears. There is a speed reducer which slows the motor speed so it can drive the rear axle. Whenever the bus is moving, the motor is always in "gear". It runs at approximately 12,500 RPMs at a maximum bus speed of 55 MPH. The motor turns backwards in order to drive the bus in reverse. It does not "hurt" the motor to apply full torque at zero RPM or to "stall" the motor. There is no exhaust system that release combustion by-products into the atmosphere. There is a receptacle, for battery charging, near the right rear side panel. There are one hundred and twelve (112) valve regulated lead acid batteries mounted underneath the vehicle in the luggage compartment areas in four separate packs of twenty-eight (28) batteries each. These battery packs are called Traction Battery Packs. There are special radial "Ultra Low-Rolling Resistance" tires.

The principle elements of the electric vehicle propulsion system are the chassis controller, the battery pack, the motor controller, the power distribution unit, the motor and speed reducer which are schematically depicted in the following diagram. The following is an overview of the propulsion system operation when the vehicle is being driven.

The Chassis Controller is a microprocessor controlled device that senses the accelerator and/or brake pedal position, and converts this information into torque commands for the Motor Controller. The Motor Controller examines the torque requirement information and other operating conditions such as present motor speed and direction and implements a proprietary Vector Control Algorithm. This Vector Control Algorithm determines a Pulse Width Modulation (PWM) profile for the high power transistors. The PWM profile facili-

tates the microsecond switching capability that allows a smooth current flow from the Battery Pack through the Power Distribution Unit, to the Motor Controller which produces variable frequency 3-phase alternating current which drives the AC induction Motor. The Motor converts the electrical energy received from the Motor Controller to mechanical energy, transmits it to the Speed Reducer which turns the differential on the rear axle. In order to maintain a continuously smooth vehicle operation, the Motor Controller requires, and receives, constant shaft-speed feedback from the Motor. The Power Distribution Unit also provides 12 volt and 336 volt power for vehicle accessories. A rear mounted oil cooler is used to cool aircraft turbine oil that flows through the Motor Controller, the Motor, and the Speed Reducer.

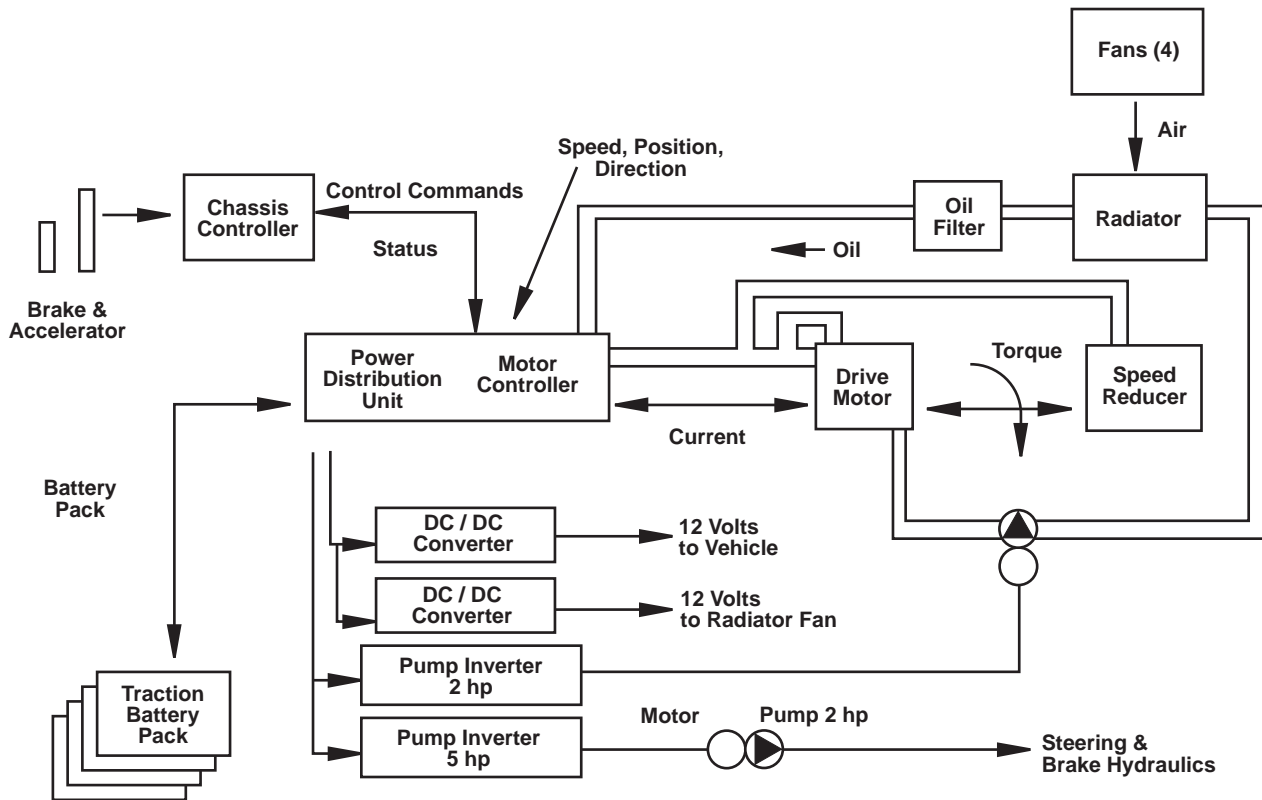

## BATTERY POWER

The electric vehicle is operated solely by electric power. The power is provided by batteries as follows.

### **Traction Batteries**

The battery packs provided to operate the electric school bus are herein identified as Traction Batteries. Each individual 12 volt battery is an EVolyte 12-EVB-1180 battery. These batteries are absorbed electrolytes which eliminates the possibility of leaking of fluids or the requirement to add water at any time. The electric vehicle is powered by one-hundred-and-twelve (112), 12 volt valve regulated lead acid batteries. Each valve regulated lead acid battery weighs approximately 66 pounds. Individual battery packs of twenty-eight (28) batteries are connected in series and are located in the luggage compartments on each side of the vehicle. Four of these battery packs are connected together in parallel. Failure in as many as 3 of the 4 battery packs will degrade the driving range and speed of the bus but will not render the vehicle undrivable in most instances or reduce its low speed torque (gradeability).

## **Start-Up and Emergency Power Battery**

The vehicle is provided with a single 12 volt lead acid battery which provides the start-up power for the vehicle 12 volt power system and emergency power to the bus electronics for emergency flashers and lights in the event of a drive system failure. The bus electronics will run off this battery when the drive power system is off or disabled. This battery is located within a compartment under the bus system circuit panel located outside of the drivers' window. This battery is provided power to keep it charged from a DC/DC converter during system operation. In an event of failure to the traction battery system and the DC/DC converter, this 12 volt battery will provide service to the vehicle electronics. This 12 volt battery closes a relay between the vehicle 12 volt system and the motor controller 12 volt electronics. The DC/DC converter maintains the charge to the 12 volt batteries during motor operation. The system also charges the 12 volt batteries during traction battery charging. This battery is charged at any time the bus traction system is on or being charged.

## **Drive Train Cooling System**

The drive train cooling system consists of fans, radiator, battery, pump, motor, and oil which flows through the system. The oil used in this cooling system is Exxon 2389 and is pumped from the motor, to the radiator where it is cooled by the fans. After the oil is cooled it flows from the radiator through a filter and then flows to a motor and speed reducer in parallel. Oil from the speed reducer flows to the motor oil sump where it is picked up by the oil circulation pump.

## **MOTOR CONTROLLER**

The motor controller is located in the right side rear compartment behind the rear tires. The motor controller contains five (5) printed circuit boards and numerous chassis mounted components. It provides variable voltage, variable frequency, 3-phase AC-output power, forward and reverse phase sequences, and vector torque control. When powered by a 336 volt DC Traction Battery Pack, the motor controller is capable of generating up to 640 amperes of AC line current, which will produce 250 foot-pounds of torque at the motor shaft. It can power the motor up to 230 shaft horsepower. The motor controller weighs approximately 80 pounds and is cooled by Exxon 2389 turbine oil and two (2) fans located in the motor controller cover.

**WARNING: The motor controller is a very-high power device, capable of inflicting serious bodily harm or death through electrical shock. The electronics compartment should only be opened by a qualified technician.**

## **MOTOR**

The motor is a 3-phase, oil cooled, AC induction motor. It is capable of delivering +/- 250 foot pounds of torque. The motor is capable of 12,500 RPM in a forward direction (at 55 mph) and 4,500 RPM in reverse (up to 15 mph). The motor controller limits the reverse speed to a programmable preset limit. Cooled by Exxon 2389 turbine oil, the motor weighs approximately 225 pounds.

## **VEHICLE PERFORMANCE**

The electric powered Blue Bird TC school bus is equipped with ultra low rolling resistance tires. With the traction battery pack fully charged, it is capable of approximately an 70 mile range at a constant 45 mile per hour velocity. The vehicle can accelerate from a standing start to 50 miles per hour in approximately 30 seconds. These figures are based on initial testing on level terrain, and subject to operator performance. Rapid acceleration reduces range capability of the vehicle.

## VEHICLE OPERATION

### **Efficiency of Energy**

To maintain smooth operation of the vehicle and efficiency of energy, the bus should be operated with a constant easy pressure on the accelerator. The battery energy per mile required to move the bus increases with speed. The range decreases with speed. A ten (10) MPH difference in speed will bring about a ten (10) mile difference in vehicle range. Properly inflated tires have less rolling resistance than under inflated tires. Warm tires have less rolling resistance than cold tires.

The motor will not produce torque or power if the brake pedal is pressed at all. A slight touch of the brake will disable the motor controller, prevent it from applying any further acceleration power, and initiate electronic braking called regenerative braking.

### **Rolling**

**WARNING: There is no parking pawl to hold the electric vehicle. When brake pedal or parking brake is not applied, the bus will roll forward or backward, depending on the slope of the road surface, whether or not the vehicle is in neutral. While the bus is stopped, always have a foot on the brake pedal or engage the parking brake.**

**When starting from a stop, the bus will roll freely after release of the brake until the motor torque accelerates the bus, unless accelerating torque is applied prior to release of the parking brake. Be careful of people/objects in front of or behind the bus when moving from a stopped condition.**

### **Regenerative Braking System**

The electric vehicle is equipped with a regenerative braking system that provides additional braking assistance to the standard school bus hydraulic braking system. The regenerative braking system operates as follows. Upon application of the hydraulic brake pedal, the motor becomes a generator and provides additional braking to the bus. The mechanical energy of the moving bus is converted into electrical energy that is returned to the Traction Battery Packs. The energy that is returned to the Traction Battery by the regenerative braking will increase the range of the bus. This increase can be as much as 20 % as compared to a system without regenerative braking.

The first movement of the brake pedal applies the regenerative braking by responding to a small rise in hydraulic brake fluid pressure. The regenerative brakes will provide aggressive braking for the vehicle during the first part of the brake pedal movement with very little pedal effort. If more aggressive braking or a panic stop is required, the hydraulic power disc brakes are still present and can be fully activated by pressing the pedal with normal foot pressure. Under most conditions, the regenerative brake will provide almost all of the necessary braking. This braking combination will extend the natural life of the friction brakes. It will not "hurt" the bus or the regenerative brakes to "ride" the regenerative brakes down a long hill which under normal circumstances will overheat or destroy hydraulic friction brakes if used in this manner.

## INSTRUMENT CLUSTER

Most of the features on the instrument cluster are typical for all school busses. This section will cover the changes to the instrument cluster that are specific to the operation of the all electric school bus.

1. **Amp Hour Gauge** - This gauge represents the available energy of the electric vehicle. This indicates range much in the same way a combustion engine fuel gauge provides the status of gasoline available. As in a combustion engine operation the range is determined by the efficiency of driving and the speed of the vehicle. Use this gauge as an indicator of the % of a full battery charge available. The amp hour reading multiplied by the battery pack voltage is the remaining energy in the battery pack in units of watt hours.

**Volt Meter** - Shows the voltage of the 12 volt battery system that operates the vehicle 12 volt electronics. This gauge will read the same as if the vehicle was a standard internal combustion powered vehicle.

2. **Oil Pressure Gauge** - Shows the pressure of oil in the electric motor cooling system. The vehicle is cooled by oil rather than water. The oil pressure range for this vehicle is 50 - 90 psi.  
**Oil Temperature Gauge** - Shows the temperature of the oil in the motor cooling system. The maximum operating range is a temperature of approximately 185 degrees.
3. **System Voltage Gauge** - Shows the amount of voltage available for operation of the electric vehicle at any given time. At full charge this gauge will read approximately 350-360 volts. During vehicle operation the voltage will decrease with distance traveled and increase some during regenerative braking. Comparisons of the system voltage gauge and the amp hour gauge will provide the operator with the estimated vehicle range before recharge is necessary. Do not attempt to push the vehicle range to its limits. Vehicle range is very dependent on efficiency of operation and other road conditions.
4. **Speedometer** - Indicates vehicle speed in miles per hour.
5. **Additional Instrument Cluster Gauges** - The remainder of the instrument cluster gauges operate as they would on a combustion engine vehicle. Use these indicators in the normal operation of the vehicle.

## PRE-DRIVING REQUIREMENTS

The following paragraphs detail procedures you must follow prior to starting the electric vehicle.

**NOTE:** If, in the course of inspecting, driving or charging the batteries in the vehicle, you have any questions or problems, notify the appropriate department. Do not attempt to add water to this type of battery, it is not possible.

### **Walk-Around**

Prior to starting the electric school bus, you must walk around its perimeter, to check for body integrity, and to check for obstructions in any direction. When walking around the vehicle, it is also important to check the ground under the vehicle for fluid leaks from the power steering, brakes, diesel heater, or the oil cooling system. If you observe any leaks, immediately notify the appropriate department. DO NOT start the vehicle if you think it is leaking. The following fluids are used in the operation of the vehicle.

- Exxon 2389 turbine oil - light yellow color - light viscosity - distinctive odor.
- Hydraulic power steering fluid - light color - light viscosity.
- Hydraulic brake fluid - red color - light viscosity.
- Diesel fuel for heater - light color - distinctive odor.
- Water for diesel heater - 50% water / glycol mix - light green color.

**CAUTION: Upon recognition of any significant fluid leaks; note location and type. Do not operate the vehicle until a determination of fluid and problem is diagnosed and corrective action is completed. Moving the vehicle away from a fluid spot on the ground makes it hard to find the source of the leak.**

### **Tires**

The electric vehicle is equipped with Michelin 11R22.5 Radial XT1 “Ultra Low Rolling Resistance” tires. Accurate tire pressure readings are important for evaluation of vehicle performance. Check each tire, and note the tire (i.e. right front, right rear, left front, left rear) and its air pressure. The cold tire pressure should be 100 pounds per square inch (psi). The correct tire pressure is required for attaining maximum vehicle range. Tires with low pressure will consume more energy per mile from the Traction Battery Packs than tires with the correct pressure. If the extra energy drain is high enough, the battery could run out of energy before the scheduled route is completed. The vehicle range is computed on average speed, careful acceleration, and proper tire pressure. Check cold tire pressure in all tires prior to beginning route. Inflate as indicated.

## STARTING THE ELECTRIC VEHICLE

The following steps must be followed to start the vehicle. For safety and performance considerations, follow these steps in their listed order.

1. Ensure the charge cable is not connected to the vehicle and all access panels are closed and locked.
2. Ensure the parking brake is applied.
3. Fasten your seat belt.
4. On the dash, there are panels that look like the ones shown below. This device is used for selection of vehicle operating modes. Ensure the selector button for Park (P) is pressed.
5. Turning the key to the first position engages power to the bus electronic systems. To start the electric drive system turn the key to the start position. There is no need to hold the key. No ignition sounds will be heard. Let the spring loaded key return to its normal position as it would with an internal combustion engine.

All lights on the operating modes selector panel will come on, then go off. The Park (P) light will illuminate and remain lit if all starting conditions are GO.

6. Check voltage and current readings on dash.

Voltage will read in a nominal range of approximately 350-360 for a full charge status and the amp hours gauge will read accordingly.

If voltage reads less than 336 after start, do not drive. Charge the bus as soon as possible. The current meter should read about -7 amps. The negative sign (-) means that current is being drawn from the Traction Battery Packs. It will read positive (+) when current is going back into the battery pack which occurs during regenerative braking.

7. Place your foot on the brake and press the Drive (D) on the operating mode selector panel. When D is successfully engaged, the D selector will illuminate.

Or, you may press (R) Reverse. When reverse is successfully engaged, the R selector will illuminate. To select Drive or Reverse, the bus must be at zero speed (not even the slightest roll) and the brake pedal depressed. The driver cannot change from one selection (D), (R), if the vehicle is moving. You cannot move the bus until the D or R selector is fully illuminated (not blinking) prior to disengaging the parking brake or releasing the brake pedal to begin moving the bus.

A blinking light requires the following steps to restart the bus.

- Keep / return you foot to the brake (on a hill engage the parking brake)
  - Return selector button to N and wait for the N selector to illuminate.
  - If after a few trials the selector continues blinking turn the key to the off position.
  - Wait a few seconds for the controller to reset and begin start-up procedures from the beginning.
  - If a continued start-up failure occurs, turn on the emergency lights and call for assistance.
8. Upon a successful start, release the parking brake and begin to drive. Remember, the vehicle will roll on a grade. If you are stopped on a grade with your foot on the brake, the bus will roll backward when you release the hydraulic brake pedal to move to the accelerator. To hold the bus on a hill and to prevent "roll back" the accelerator and brake pedal may be applied at the same time. When the vehicle speed reaches 5 MPH or greater the brake pedal will override the accelerator and no more power will be applied to the drive wheels.

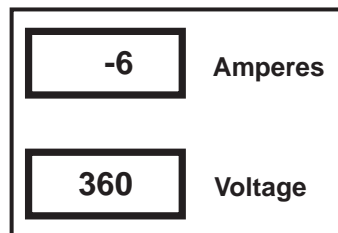

Located Right Side of Instrument Panel

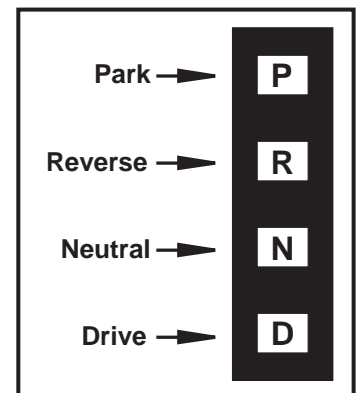

Located to Right of Instrument Panel

**WARNING: Ensure that the Operating Mode Selector PARK button is depressed. Any other selection may allow movement of the vehicle upon ignition switch on.**



## Changes in Voltage and Current Readings

The following status of voltage and ampere readings on the digital gauges should be checked. The gauges are located to the left of the operating modes selector panel.

### Voltage

As the vehicle accelerates or is otherwise driven by the motor, the average voltage will decrease indicating that current is coming out of the Traction Battery Packs. Voltage will drop some during any acceleration.

During braking, the regenerative braking system will return current to the Traction Battery Packs causing an increase in voltage. This recaptured energy will increase in the vehicle operating range.

### Current

Current on start-up will be a nominal -6 to -9 amps.

Current will read negative (-) when power is being supplied by the traction battery system.

Current will read positive (+) when power is being supplied to the traction battery system (regenerative braking - system charge).

## Start-Up Problems

The following conditions / problems may occur when attempting to start the electric drive system:

Bus electronic systems do not come on when key is turned to ignition,

This situation indicates the 12 volt battery may be dead. This battery is located in the compartment below the circuit panel outside the driver's window. The release latch is inside driver's wall just behind the driver's seat.

Jump starting the 12 volt battery will allow for drive operations, but battery should be checked and either charged or replaced as indicated.

Possible blown fuses.

Check bus fuse panel (outside front of bus behind driver's wiper.

Check Motor Controller fuses (in right side rear compartment)

Check F1 & F2 on Relay Box (in right side rear compartment)

Operating modes selector panel lights do not come on at second ignition position. This indicates electric drive start failure

12 volt battery is dead (jump start as indicated below)

Possible blown fuses inside fuse panel.

System battery connections disconnected.

System batteries not charged.

System battery charging system connected.

Motor controller failure.

Each of these situations require checking traction battery system charge status, 12 volt battery charge status, all applicable fuses.

In the event of motor controller or motor failure contact the manufacturer for assistance.

It is possible to jump start the 12 volt system. In the case of 12 volt battery being dead, the reason must be diagnosed and if recommended, the 12 volt battery may be changed out for a normal 12 volt auto battery.

Start-up may appear to have been successful, however the bus will not move when either (D) or (R) is selected. This condition will occur if the charging system has not been disconnected. There is an interlock switch located in the charging compartment door that disables the power bridges to the bus electronics. The charge connection must be disconnected and the door closed and locked prior to the bus being started.

## DRIVING DO'S and DON'TS

The following paragraphs include information for efficient and safe operation of the vehicle.

### In the Event of Breakdown

If the vehicle breaks down while in your use, pull closely and safely to the side of the road and activate the emergency flashers. Immediately notify the appropriate department. **DO NOT attempt any repair of the vehicle.**

## **In the Event of Accident**

If you are involved in an accident follow normal established procedures. Remain with the vehicle as timely notification of the authorities is essential. **DO NOT, under any circumstances, move the vehicle before instructed to by the authorities.** Activate the emergency flashers. Remain with the vehicle and be prepared to inform the arriving authorities that the vehicle is equipped with 112 spill proof valve regulated lead acid batteries configured with high enough voltage to be lethal.

**WARNING: DO NOT attempt any repair to the vehicle.**

## **Impact Switch**

The impact switch disconnects high voltage power from the traction batteries to the motor controller under minimum impact. In this situation or in emergency conditions only, the impact switch may need to be reset. This is a red button switch located in the right hand front battery compartment behind the front corner post. To reset, depress the switch.

## **Some Driving Tips**

Always wear your seat belt.

**WARNING: It is essential that you become accustomed to using your parking break. There is no parking pawl that keeps the vehicle in place should you neglect to apply the parking brake.**

Take your time getting used to the braking system. The combination of the standard hydraulic brake system and the regenerative brake system can stop the bus very aggressively with little pedal pressure. If you slow the bus down in a normal non-aggressive manner, the regenerative brakes will absorb almost all of the mechanical energy of the moving bus and the life of the friction brakes will be greatly extended. Always maintain a safe distance between your and those around you.

**WARNING: When starting from a standing stop on a hill, the vehicle will behave much like a manual-transmission equipped vehicle. As such, it may drift backward before enough torque is applied to the wheels to begin moving. Be sensitive to this, and always be aware of vehicles and pedestrians either in front of or behind you.**

The electric vehicle is much quieter than standard internal combustion engine vehicles. Inattentive pedestrians may put themselves at risk if they rely on their ears more than their eyes. You must try to anticipate these situations and utilize your defensive driving skills to ensure the safety of those around you and yourself.

The bus is equipped with an amp hour gauge, which reads like a “gas” gauge, in that it is an indicator of the remaining “fuel”. You should check this gauge frequently, and try to avoid situations where you cannot reach a charging station.

Should you lose power steering capability, immediately pull the vehicle to a safe location and notify the appropriate department.

## **SHUTTING DOWN THE VEHICLE**

1. Press “Neutral” (N) on the operating modes selector panel. When neutral is successfully engaged, the N selector button will be lit.
2. Press the “OFF” (OFF) selector to disengage the power bridges to the drive train system.
3. Engage the parking brake.
4. Turn the key to the “off” position and remove the key.
5. Lock the vehicle.

## CHARGING THE VEHICLE

Following are the steps for charging the lead acid battery-powered vehicle.

1. Pull the vehicle near the charging station. Position the vehicle so that the right rear side panel is near the charging station.
2. Shut down the vehicle in accordance with the procedures listed above but do not lock the vehicle yet.
3. Locate the on-vehicle charge receptacle. It is near the right side rear panel past the two battery rack panels. The receptacle is rectangular in shape with a key lock.
4. Verify that the charger you plan to use has been approved for the bus and has the correct Meltric connector.
5. Open the battery cable storage cabinet, which is mounted on the wall at the charging station, and unwind enough cable to reach the vehicle charging receptacle.
6. Connect the charging cable to the vehicle receptacle by inserting the pins on each side of the cable connector into slots on the vehicle receptacle and pushing down on the handle until the connector snaps into place.
7. Charging the Traction battery packs requires 8-10 hours depending on state of charge at beginning of charge cycle.
8. The charger will automatically shut itself off when the charge cycle is complete.

## ELECTRIC MOTOR MAINTENANCE

Inspect units at regular intervals. Keep units clean and ventilation openings clear of dust, dirt and other debris. Lubricate units per instructions and instruction plate on unit.

**CAUTION: Excessive lubrication may damage unit. Do not over grease.**

**WARNING: Disconnect all power sources to the unit and discharge all parts that may retain an electrical charge before attempting any maintenance or repair.**

Screens and covers must be maintained in place when unit is in operation. Motors for use in hazardous locations - Class I & II installation: Repairs of these motors must be made by the manufacturer or authorized service station approved by the manufacturer and U.L. to maintain the U.L. listing. The U.L. listing applies to the electrical motor only and not to the belt or gear transmissions or other devices that may be connected to the motor.

## FLUID CAPACITIES

ITEM	TYPE of FLUID	CAPACITY (Quarts)
Power Steering	Dexron III	5
Brake Fluid	DOT 3 Approved	2.5
Motor / Cooling	Exxon Turbo Oil 2389 (MIL-L-7808J)	17
Heating Fluid	Ethylene Glycol 50/50	45.5
Heater Fuel	Diesel	20

## LUBRICATION INSTRUCTIONS

### **Power Steering / Propulsion Motor Cooling Pump & Motor**

Some small motors have sealed-for-life bearings which require no relubrication. Regreaseable bearings are shipped with a high quality, wide temperature range grease in the bearings.

Motors can be regreased by stopping the motor, removing the drain plug and pumping new grease into the fill hole. Run motor with drain plug removed until excess grease has been discharged (minimum 10 minutes). Stop motor and replace drain plug.

Units that operate at speeds greater than 1800 RPM should be lubricated on a more frequent maintenance schedule depending on duty cycle. Use a low pressure grease gun and avoid over greasing.

<b>SUGGESTED REGREASING INTERVALS</b>									
<b>SERVICE</b>	<b>MOTOR HORSEPOWER</b>								
	<b>UNDER 50</b>	<b>50 - 100</b>	<b>100 UP</b>						
A	3 - 5 Yrs.	2 - 4 Yrs.	2 Yrs.						
B	2 - 4 Yrs.	1 - 1/2 Yrs.	1 - 1/2 Yrs.						
C	1 - 2 Yrs.	1 Yr.	6 Mos.						
D	4 Mos.	4 Mos.	3 Mos.						
<b>SERVICE SYMBOL</b>	<b>TYPE OF SERVICE</b>								
A	In frequent operation or light duty in clean atmosphere.								
B	8 - 16 Hrs/Day in clean, relatively dry atmosphere.								
C	12 - 24 Hrs/Day, heavy duty, or if moisture is present.								
D	Heavy duty in dirty, dusty locations; high ambients; moisture laden atmosphere; vibration.								
<p><b>Recommended Greases</b> Use the following greases or equivalent grease unless a special grease is specified on the nameplate.</p> <table border="0"> <thead> <tr> <th><b>MANUFACTURER</b></th> <th><b>TRADE NAME</b></th> </tr> </thead> <tbody> <tr> <td>CHEVRON</td> <td>SR I #2</td> </tr> <tr> <td>SHELL</td> <td>DOLIUM R</td> </tr> </tbody> </table>				<b>MANUFACTURER</b>	<b>TRADE NAME</b>	CHEVRON	SR I #2	SHELL	DOLIUM R
<b>MANUFACTURER</b>	<b>TRADE NAME</b>								
CHEVRON	SR I #2								
SHELL	DOLIUM R								

# INDEX

<b>Access Doors</b> .....	<b>30</b>	<b>Brake Maintenance Chart</b> .....	<b>85</b>
<b>Air Brakes</b> .....	<b>72</b>	Air Brake System .....	85
Air Brake Adjustment .....	72	Hydraulic Brakes (Disc) .....	85
Draining Air Tanks .....	73	Shoe-Type Brakes (Air) .....	85
Fuel Stop Solenoid .....	72	<b>Chassis Component Maintenance Chart</b> .....	<b>86</b>
MGM Service & Parking Brake .....	73	Accelerator System .....	86
Parking .....	72	Automatic Transmission .....	86
Shrader Valve .....	73	Drivelines .....	86
<b>Allison Automatic Transmission</b> .....	<b>65</b>	Electrical System .....	86
Accelerator Control .....	66	<b>Circuit Breakers</b> .....	<b>21</b>
Allison Transmission Cable Adjustments .....	66	<b>Coach Identification</b> .....	<b>4</b>
AT 545 .....	65	Axle Record & Chassis Service Number .....	5
Check Transmission Light .....	68	Body Serial & Service Number .....	5
Cold Weather Start MD3060 .....	69	Vehicle Certification .....	4
Downshift Control AT545 .....	68	<b>Compressed Natural Gas</b> .....	<b>58</b>
Downshift or Reverse Inhibitor MD3060 .....	68	Antiknock Properties .....	64
MD3060 Gear Selection .....	67	Code of Federal Regulations .....	59
MD3060 World Transmission .....	66	Cold Start .....	64
Transmission Breather .....	70	Compressed Natural Gas Filters .....	61
Transmission Oil Temperature .....	69	Compressed Natural Gas Fuel .....	61
Using Engine to Slow the Vehicle .....	69	Energy Conversions .....	64
Using the Electric Retarder .....	68	Flammability .....	63
<b>Axle Maintenance Chart</b> .....	<b>84</b>	Fuel Composition .....	62
Front Axle .....	84	Fuel System Description .....	59
Front Axle Steering .....	84	Fuel Toxicity & Safety .....	63
Rear Axle .....	84	Introduction .....	58
Tires .....	84	Maintenance .....	65
<b>Body Component Maintenance Chart</b> .....	<b>87, 88</b>	National Fire Protection Association .....	58
Air Stop Arms .....	87	Operation & Maintenance of Components .....	64
Body Mounting .....	88	Owner / Operators Responsibilities .....	58
Bus Body Care .....	87	Refueling .....	62
Destination Signs .....	87	Safety Cautions & Warnings .....	59
Electric Stop Arms .....	87	Specific Gravity .....	63
Emergency Equipment .....	87	Starting Procedure .....	64
Emergency Exits .....	87	Vehicle Performance & Emissions .....	64
Heaters .....	88	<b>Cooling System</b> .....	<b>76</b>
Jackknife Door .....	87	<b>Destination Signs</b> .....	<b>11</b>
Mirrors .....	88	<b>Door / Brake Interlock</b> .....	<b>74</b>
Outward Opening Door .....	87	Principles of Operation .....	74
Power Jackknife Door .....	87	Lock System .....	74
Seats .....	88	<b>Body Tie Down</b> .....	<b>31</b>
Vandal Locks .....	87		
Windows .....	87		

<b>Doors</b> .....	<b>32</b>	<b>Engine Operating Instructions</b> .....	<b>55</b>
Continuing Maintenance Requirements .....	32	Antifreeze .....	57
Electric Outward Opening Door .....	34	Cold Start Aid .....	56
Jackknife Door .....	32	Diesel Engine Starting Procedure .....	55
Power Jackknife Door .....	33	Engine Exhaust Caution .....	55
Outward Opening Door .....	32	Engine Warning System .....	56
Security Lock .....	35	Starting With Boost Cables .....	55
		Using Engine as a Brake .....	56
<b>Doran Warning Light Monitor</b> .....	<b>18</b>	<b>Fan Clutch</b> .....	<b>76</b>
Diagnosis .....	19	Fan Clutch Wiring Harness .....	76
Repair Procedure .....	18	Operation .....	76
Tools & Supplies Required .....	19	Troubleshooting .....	76
<b>Electric Vehicle Information</b> .....	<b>90</b>	<b>Forward</b> .....	<b>4</b>
Battery Power .....	91	<b>Flat Floor Units</b> .....	<b>15</b>
Charging the Vehicle .....	98	Seat & Restraining Barrier Installation .....	15
Driving Do's & Don'ts .....	96	<b>Front Access Panels</b> .....	<b>30</b>
Electric Motor Maintenance .....	98	<b>Fuel &amp; Lubricant Requirements</b> .....	<b>57</b>
Fluid Capacities .....	98	Diesel Fuel .....	57
Functional Description .....	90	Recommended Lubricant .....	57
Instrument Cluster .....	93	<b>General Data</b> .....	<b>89</b>
Introduction .....	90	Dimensions .....	89
Lubrication Instructions .....	99	Engine Oil Pressure .....	89
Motor .....	92	Fluid Capacities .....	89
Motor Controller .....	92	Rear Axle Fluid Capacities .....	89
Pre-Driving Requirements .....	94	<b>Heaters</b> .....	<b>37</b>
Shutting Down the Vehicle .....	97	Care & Cleaning of Defroster Fans .....	39
Starting the Electric Vehicle .....	95	Control Panel .....	38
Vehicle Operation .....	93	Defroster Fan Locations .....	40
Vehicle Performance .....	92	Defrosting .....	39
<b>Electrical Systems</b> .....	<b>16</b>	Driver / Passenger Comfort .....	40
<b>Emergency Equipment</b> .....	<b>23</b>	Filter .....	39
Fire Axe / Crowbar .....	24	General Information .....	37
Fire Extinguisher .....	23	Heater Access .....	38
First Aid Kit .....	23	Heater Bleeding Instructions .....	40
Flare Kit .....	24	Heater Cut Off Valve Location .....	42
Recommended Warning Device Positioning .....	24	Heater Defroster Location .....	40
Triangular Warning Device .....	24	Heater Hose Clamp Service .....	43
<b>Emergency Exit</b> .....	<b>25</b>	Heater Operation .....	37
<b>Engine Access</b> .....	<b>36</b>	Heater Water Capacity Chart .....	45
Hood Removal for Mechanics Access .....	36	Hose Repair .....	42
<b>Engine Block Heaters</b> .....	<b>45</b>	Outlet Locations .....	38
		Preventive Maintenance .....	41
		Removal of Underseat Fan & Motor Assy. ....	42

<b>Hydraulic Brakes</b> .....	<b>70</b>	<b>Operator's Compartment</b> .....	<b>7</b>
Brake Warning System .....	71	<b>Quick Reference Maintenance Charts</b> .....	<b>83-98</b>
Dual Brake System .....	70	<b>Rear Axle Vent</b> .....	<b>78</b>
Maintenance .....	71	<b>Reporting Safety Defects</b> .....	<b>4</b>
Parking Brake .....	71	<b>Seats &amp; Seat Belts</b> .....	<b>12</b>
<b>Hydraulic System Troubleshooting</b> .....	<b>75</b>	Driver's Seat .....	12
<b>Inspection</b> .....	<b>5</b>	Driver's Seat Belt Operation .....	13
Daily Inspection .....	5	Driver's Seat Belt w/Shoulder Harness .....	13
Prior to Placing New Bus in Service .....	5	Driver's Seat Lubrication .....	12
Weekly Inspection .....	6	Passenger Seat Belt Operation .....	13
<b>Instrument Panel &amp; Controls</b> .....	<b>8</b>	Seat Belt Inspection & Maintenance .....	13
Cluster Instrumentation .....	8	Seat Care & Cleaning .....	14
Dash & Instrument Panel .....	8	Seat Cushion Service (DOT Seats) .....	14
Indicator Light Panel .....	10	Seat Cushion Service (DOT Seat Belt Seats) .....	14
Liquid Crystal Display .....	10	Seat Inspection & Maintenance .....	13
Multifunction Gauge .....	9	Track Mounted Seats .....	15
<b>Introduction</b> .....	<b>3</b>	<b>Scheduled Maintenance</b> .....	<b>79</b>
<b>Jacking Instructions</b> .....	<b>54</b>	Monthly or 1,000 Miles .....	79
<b>Keeping Your Vehicle Looking New</b> .....	<b>36</b>	Monthly or 3,000 Miles .....	80
Finish Damage .....	36	3 Months or 5,000 Miles .....	80
Floors & Floorcovering .....	36	3 Months or 24,000 Miles .....	80
Foreign Material Deposits .....	36	6 Months or 6,000 Miles .....	81
Polishing & Waxing Your Vehicle .....	36	12 Months or 12,000 Miles .....	81
Washing Your Vehicle .....	36	12 Months or 24,000 Miles .....	82
<b>Light Bulb Data</b> .....	<b>17</b>	24 Months or 24,000 Miles .....	82
Exterior Lights .....	17	<b>Spare Tire Location &amp; Removal</b> .....	<b>51</b>
Interior Lights .....	17	<b>Stop Arms</b> .....	<b>27</b>
<b>Lower Side Panel Repair Procedure</b> .....	<b>51</b>	Air Stop Arm Troubleshooting .....	27
<b>Maintenance Service Keys</b> .....	<b>82</b>	Electric Stop Arm Troubleshooting .....	28
<b>Manual Five Speed Transmission</b> .....	<b>65</b>	Stop Sign Blade Failure .....	29
<b>Mirrors &amp; Mirror Adjustment</b> .....	<b>21</b>	<b>Suspension Clearance</b> .....	<b>79</b>
Exterior Mirrors .....	22	<b>Suspension Maintenance Chart</b> .....	<b>83</b>
Interior Mirrors .....	21	Neway Front Air .....	83
8" Dia. Supplemental Exterior Rearview .....	22	Neway Rear Air .....	83
<b>Noise Emissions Warranty</b> .....	<b>57</b>	Spring Suspension .....	83
		<b>Switch Panel</b> .....	<b>11</b>
		<b>TC Pitman Arm</b> .....	<b>77</b>

<b>Tilt &amp; Telescoping Steering .....</b>	<b>11</b>
<b>Tires, Wheels &amp; Rims .....</b>	<b>52</b>
Damaged Tires .....	52
Tightening Wheel Studs .....	54
Wheel & Rim Safety .....	53
<b>Towing or Pushing .....</b>	<b>31</b>
<b>Transpec Safety Vent .....</b>	<b>26</b>
Maintenance Cautions .....	26
Service & Repairs .....	26
<b>Vandal Locks .....</b>	<b>35</b>
Emergency Door .....	35
Entrance Door .....	35
Sliding Bolt .....	35
<b>Wheelbearing Adjustments .....</b>	<b>78</b>
Spicer Front Axle .....	78
Spicer Rear Axle .....	78
<b>Wheelchair Lift Maintenance Chart .....</b>	<b>88</b>
Braun Lift .....	88
Collins Lift .....	88
<b>Wheelchair Lifts .....</b>	<b>26</b>
<b>Windows &amp; Windshields .....</b>	<b>46</b>
Entrance Door Glass Replacement .....	47
Rear Vision Glass Replacement .....	48
Split Sash Window & Glass Replacement .....	46
Transit Sliding Window Maintenance .....	48
Window Latch Replacement .....	47
Windshield Glass Replacement .....	46
<b>Windshield Wipers .....</b>	<b>50</b>
Washer Solution Reservoir .....	50
Wiper Arm Removal & Installation .....	50
Wiper Assembly Replacement .....	50
Wiper Refill Replacement .....	50
<b>Winterfront Cover .....</b>	<b>29</b>



---

**Part Number: 0002749**  
**Blue Bird Corporation • P.O. Box 937 • Fort Valley, GA 31030**