

Doran Warning Light Monitor

The Doran Monitor™ is a current sensing device. If current is flowing through one of the bus lamp circuits, the monitor senses it and illuminates the corresponding monitor light emitting diode (LED). When a lamp burns out, current flow through the circuit stops and the corresponding LED on the monitor does not illuminate, indicating the outside lamp is not functioning. The Doran™ Monitor is located in the bulkhead over the windshield and slightly to the left of the driver.

Warning lights are such an essential safety feature, it is important to know when they are not working properly. This is the function of the Doran monitor. Its display is a schematic of the lights as they appear outside the bus. It continuously monitors the current in each lamp. If current is flowing through a particular bus lamp circuit (i.e., the light is on), the monitor senses this and lights the corresponding monitor bulb. If the bus lamp burns out, current ceases and the corresponding monitor bulb goes out, indicating a fault. Once the defective lamp is replaced, and the warning lights are working normally again, this also should be shown by the monitor.

The Doran monitor is a reliable, long-life device, but as with most electrical instruments, it can be overheated and damaged if an overload occurs in a bus light. Such overloads can exist if a bus light circuit becomes shorted, forcing current through a coil in the monitor that exceeds the coil's rated capacity. Short circuits can occur if improper connections are made during installations, bus repairs, etc. If the monitor has an optional thermistor overload protection, the tail light circuits are overload-protected. (Thermistors are located on the bottom of the component side of the printed circuit board.)

Doran Troubleshooting

Do not attempt to check a light emitting diode (LED) with an ohmmeter. Some digital voltmeters (DVM) have a diode checking position, which is acceptable for testing LEDs. Any repair of the Doran Warning Light Monitor™ should be referred to a qualified technician.

If the Doran Warning Light Monitor™ does not display any indicator LEDs:

- An overload situation may have created an open circuit: Check the system fuses.
- An overload (due to addition of extra lights or other loads to the circuit) or physical damage may have burned or broken a conductor on the printed circuit board: Remove the extra load and replace the damaged printed circuit board.
- Excessive vibration or abuse has resulted in a damaged monitor. Replace the printed circuit board.

If a particular LED on the Doran Warning Light Monitor™ does not display, but the bus running lights are operating properly:

- The coil is burned due to an overload. Replace the coil kit.

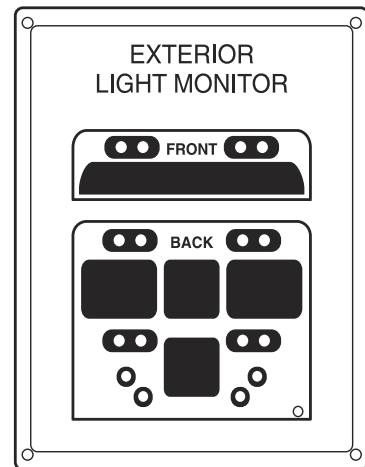

- A solder joint has weakened (a cold solder joint). Flow new solder on the connection.
- The reed switch has failed, the reed has broken, or the contacts have failed. Replace the reed switch kit.
- The printed circuit board is broken or burned. Replace the printed circuit board.
- There is an open in the LED circuit. Replace the LED.

If a monitor LED indicator is on, but the bus running light indicated is not operating, or the bus running light switch is in the off position and the monitor indicates the running lights are operating:

- Replace the coil and reed switch kit.

If neither the bus running lights nor the Doran Warning Light Monitor™ operates properly:

- The running light bulb may be burned out. Replace the light bulb.
- The overload thermistor has protected the circuit from overload. Remove the overload condition (a short; incorrect light bulb(s); Extra lights, etc.) (i.e., trailer lights, etc.)



Body Wiring Schematics

Many customer selected options which affect wiring are available for the Vision. For your convenience when you are limited to the print version of this manual, the following pages contain the main wiring diagrams representative of circuits common to most Vision bodies. However, the Tech Reference CD contains a much more comprehensive set of schematics which includes many additional diagrams pertaining to specific equipment installations.

When using the CD, click the Electrical Schematics Body link in the Bookmarks pane. The first page of the Body Electrical Schematics group contains instructions on how to use the linking and navigation features.

The drawings on the CD are in resolution-independent vector format. This allows you to zoom them at will, without the images becoming jagged as occurs with bitmap formats. This also means that you may print the drawing to your own office or desktop printer while maintaining legibility even at significant reductions.

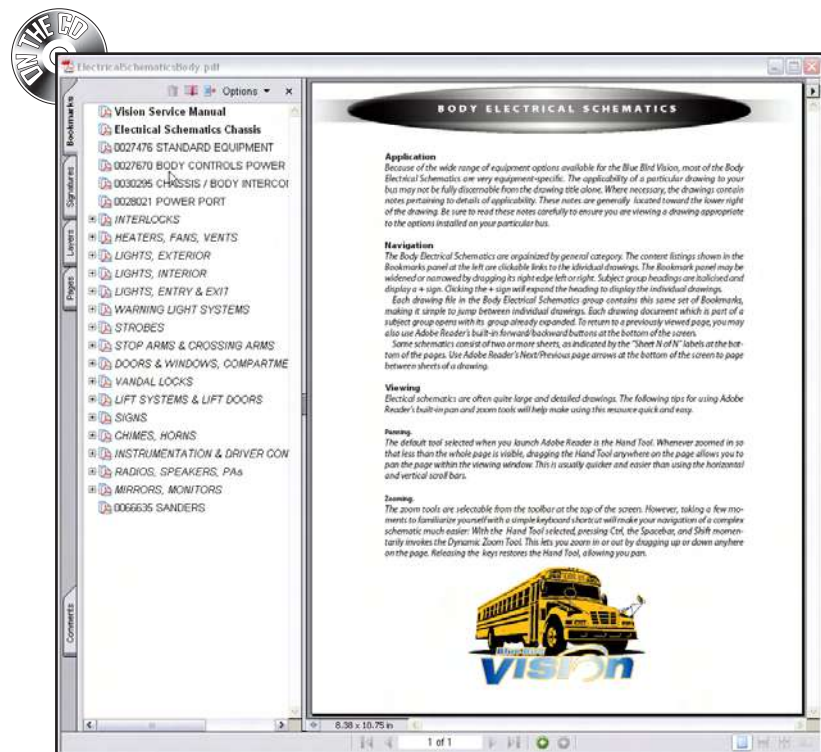

Body Electrical Schematics

NOTE:
BODY CIRCUITS WIRED THROUGH SOLENOID EXCEPT FOR
ELECTRIC CROSSING ARM & STOP ARM MOTOR FEEDS, RADIO MEMORY,
AND CIRCUITS SPECIFIED IN OTHER FEATURES. RADIO IGN. FANS,
HEATERS, OR FEATURE 30325 SUFFIXES AS INDICATED ON
PRODUCTION ORDER. (ALSO SEE DIAGRAM, WRG, FEA 30325)

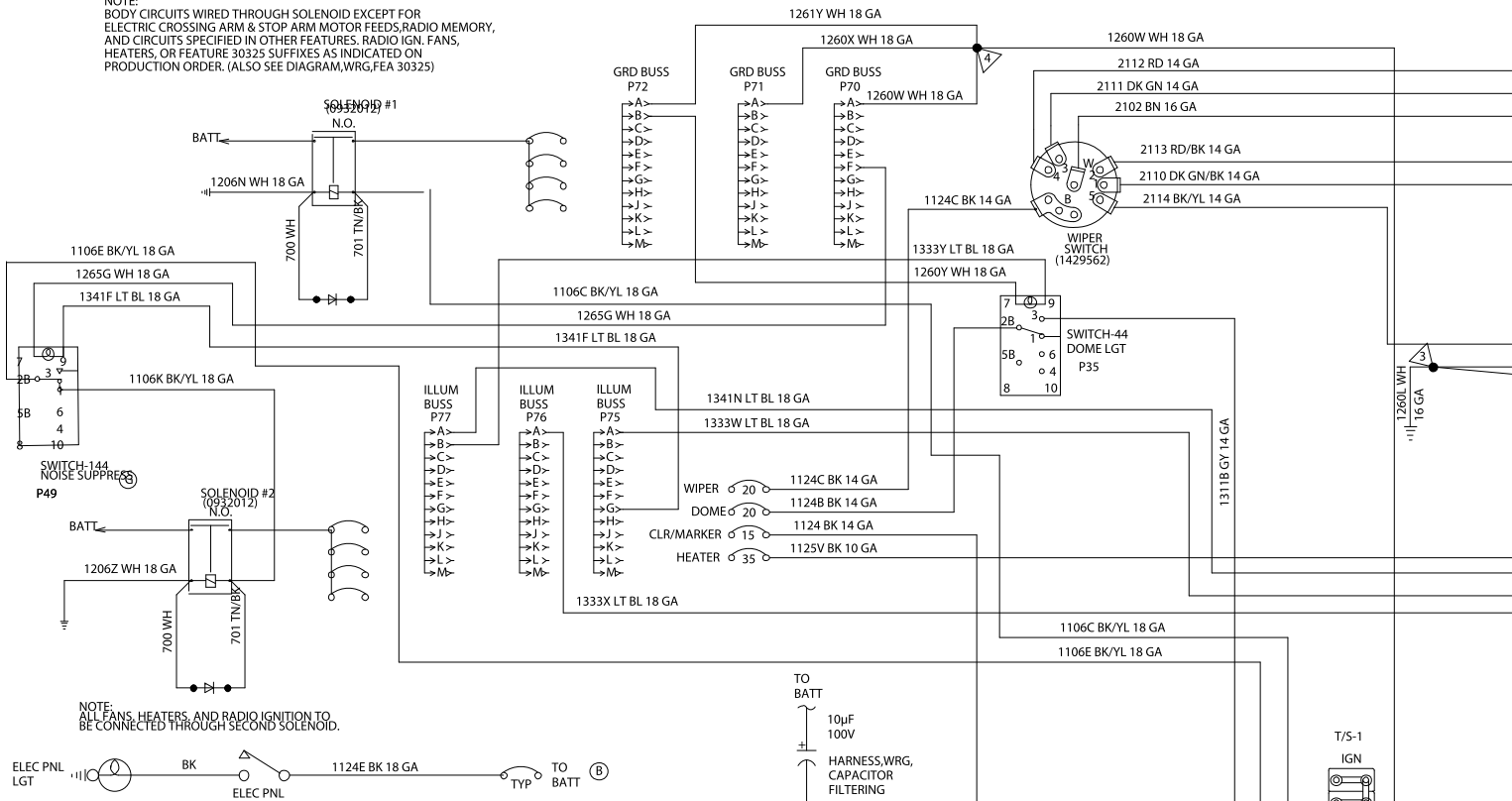

NOTE:
ALL FANS, HEATERS, AND RADIO IGNITION TO
BE CONNECTED THROUGH SECOND SOLENOID.

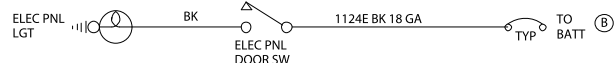

648

NUMBER OF DOME
LIGHTS VARY
DEPEND ON MODEL

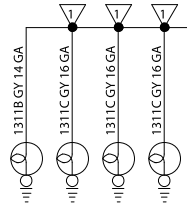

SEE SHEET 3
FOR BELTLINE LGTS
AND CLEARANCE, MARKER,
ID LIGHTS

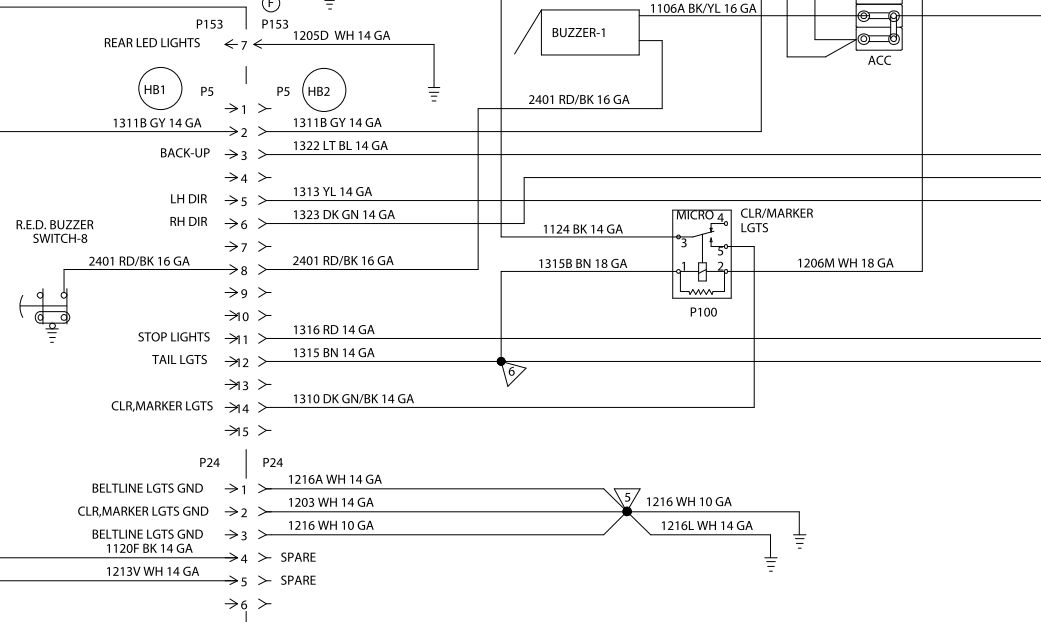

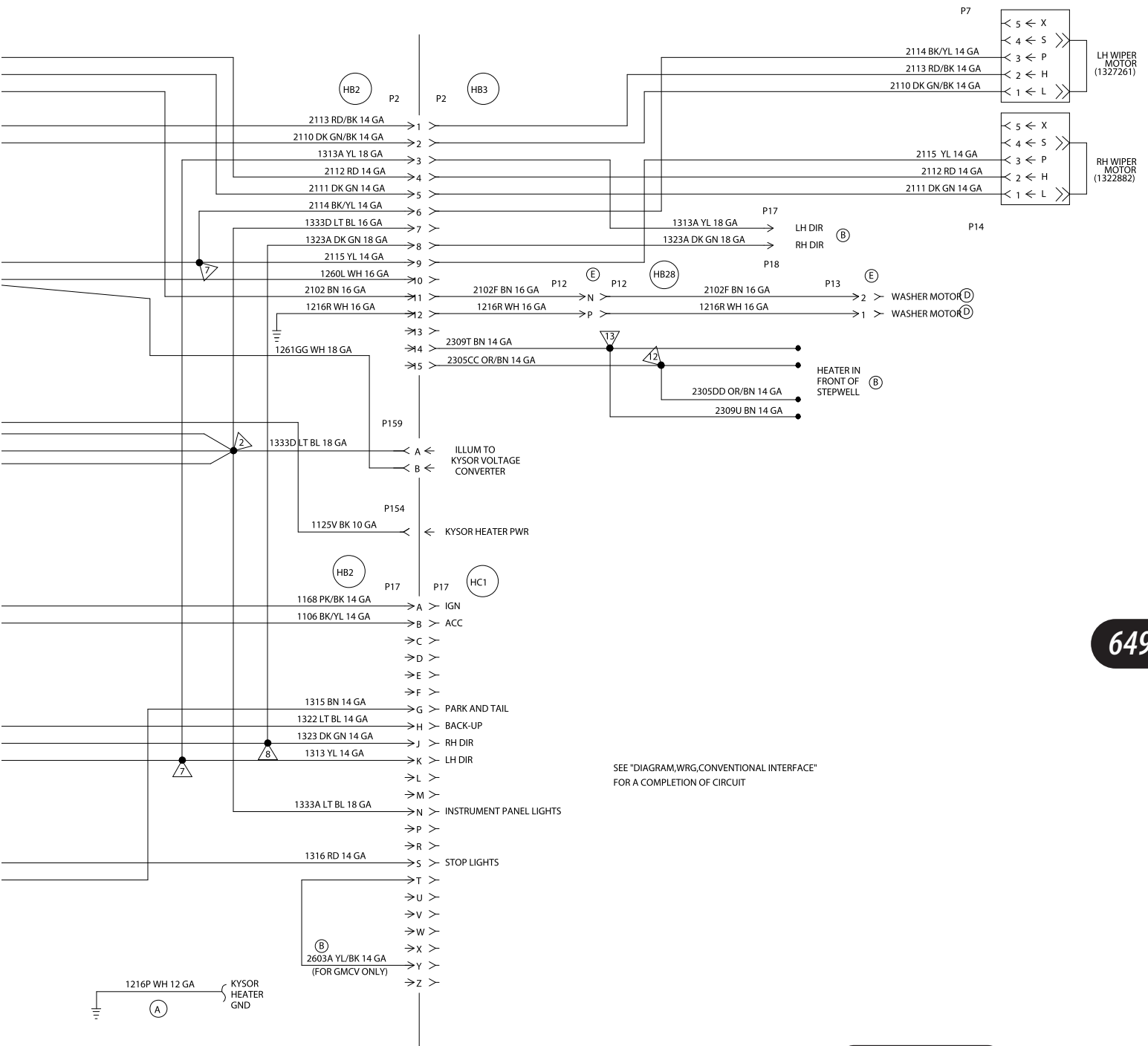

SEE "DIAGRAM,WRG,CONVENTIONAL INTERFACE" FOR A COMPLETION OF CIRCUIT



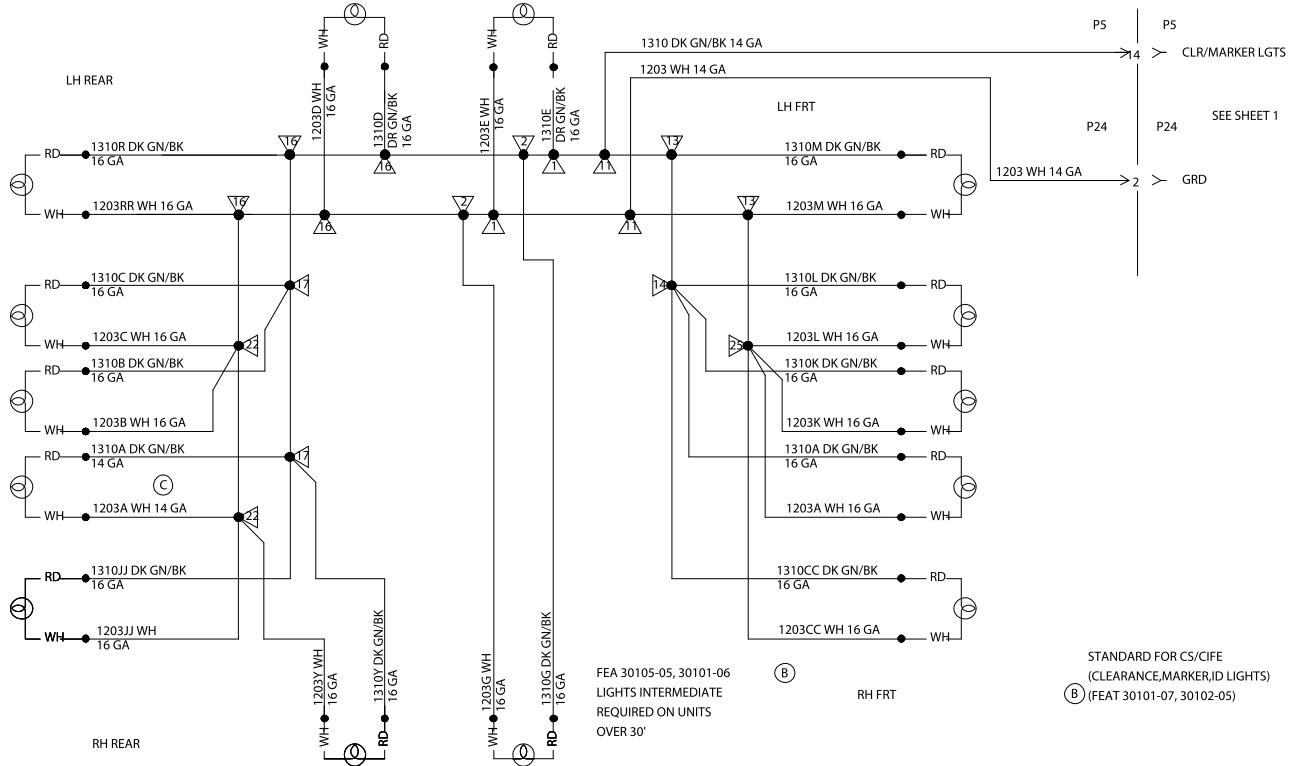

650

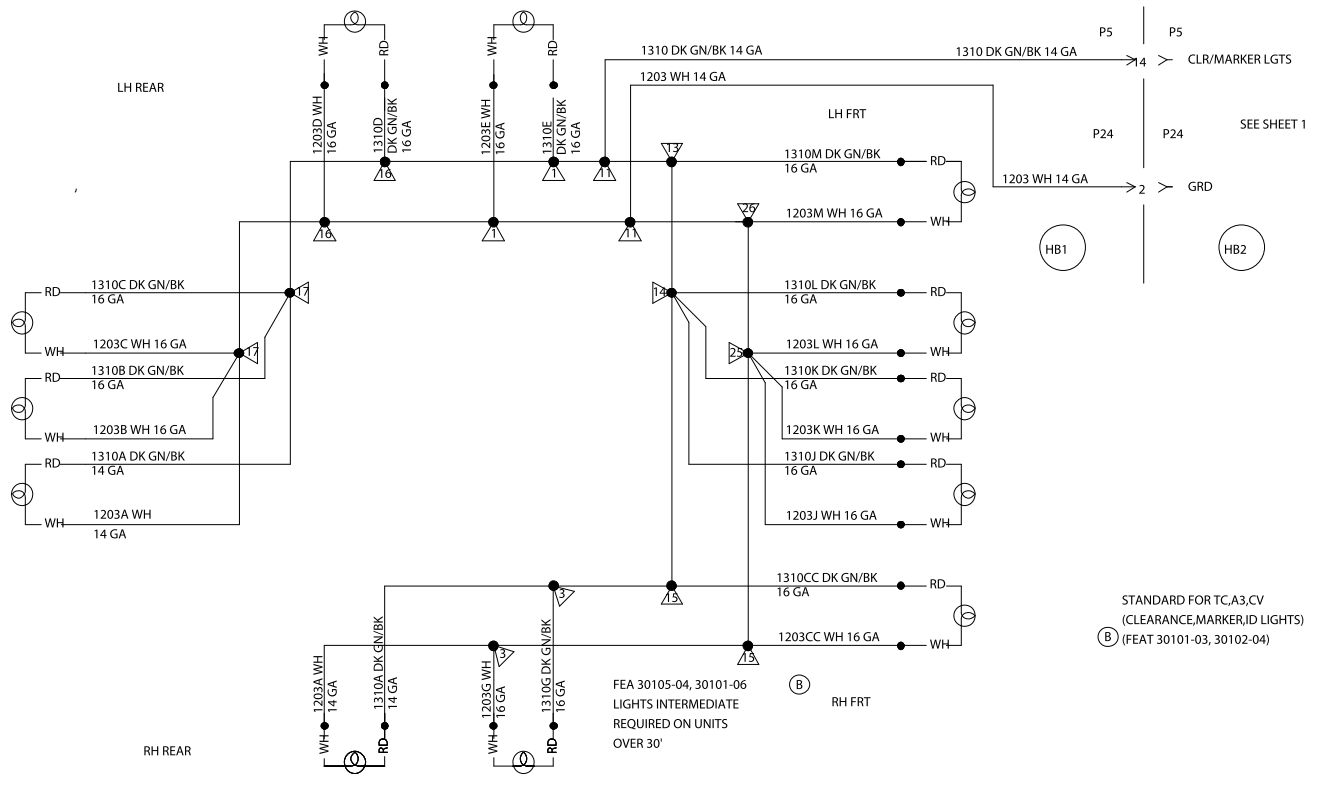

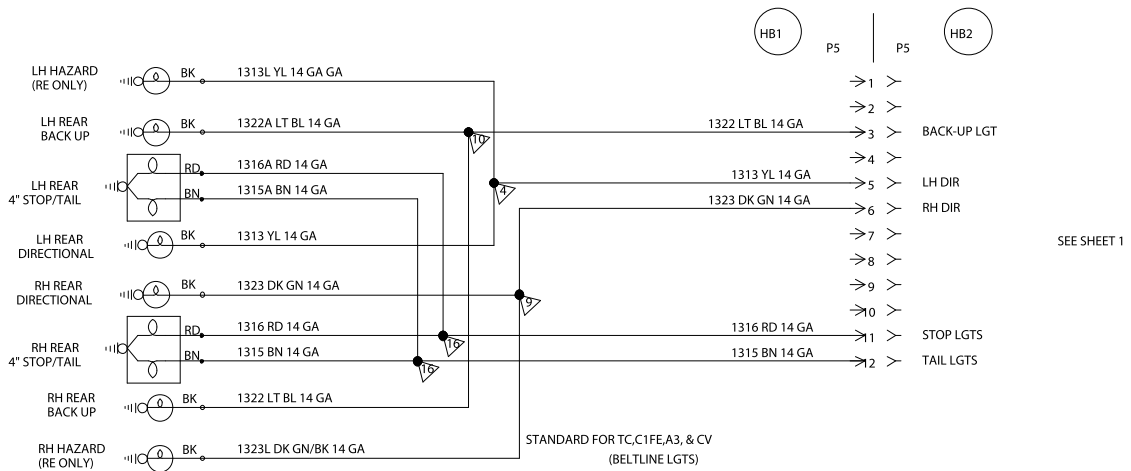
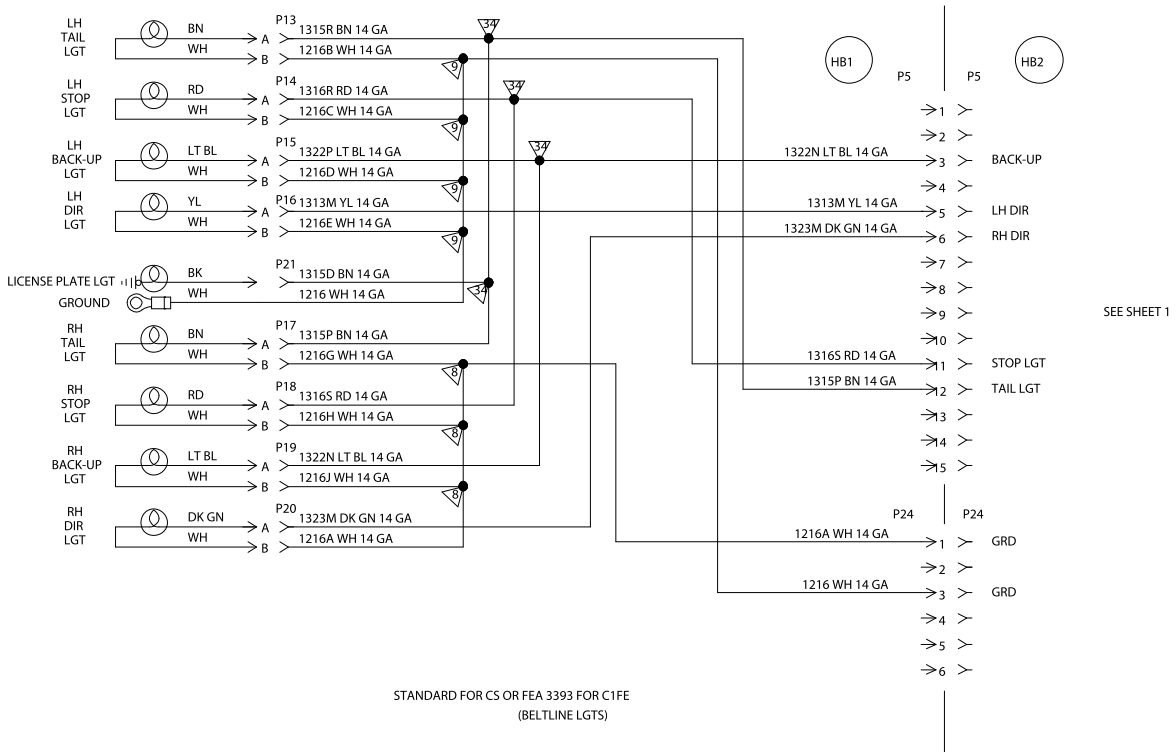

651



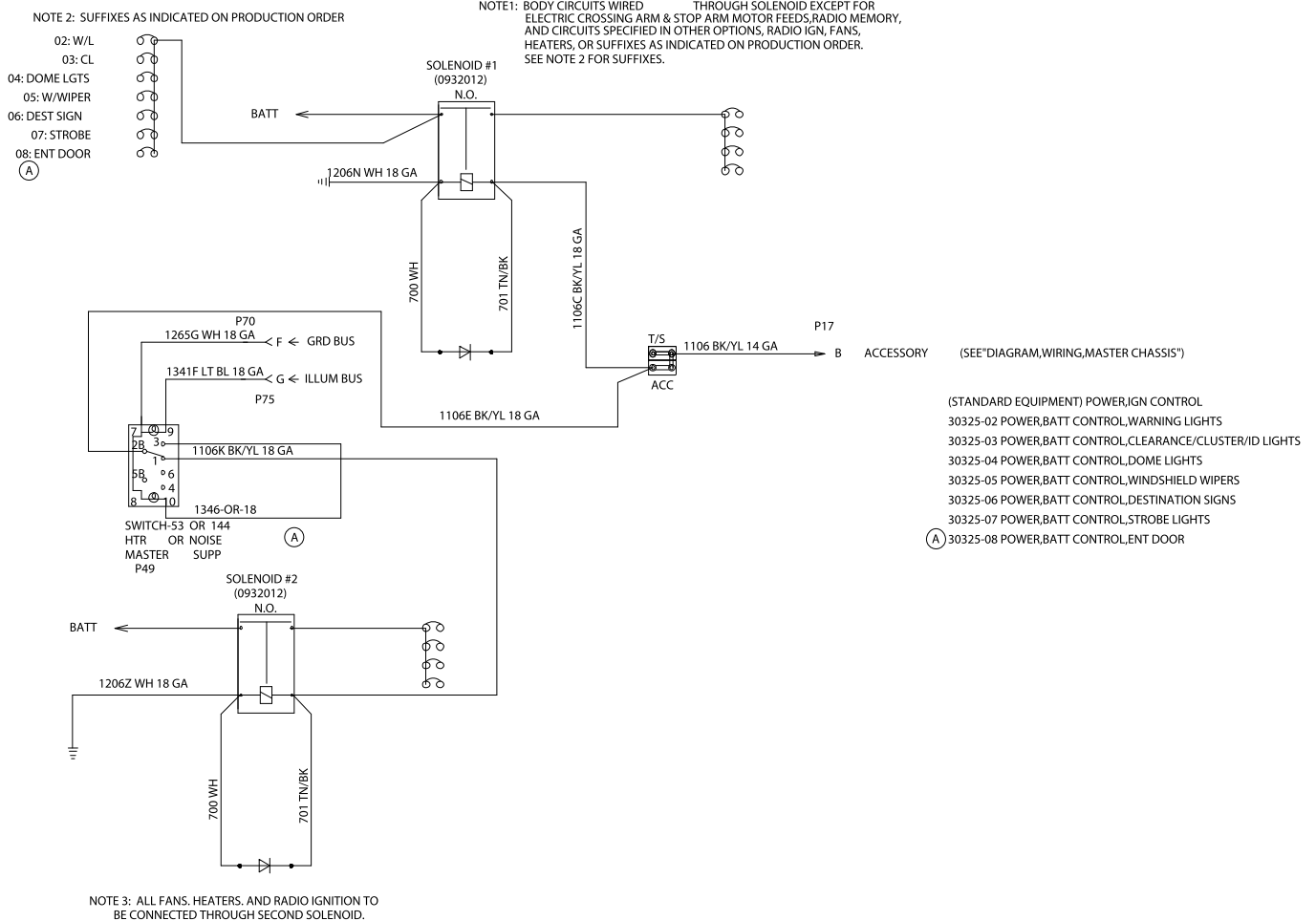

652

0027670A

DIAGRAM,WRG,FEA 30325

BODY CONTROLS POWER