

# HGS SYSTEM

## Workshop Manual

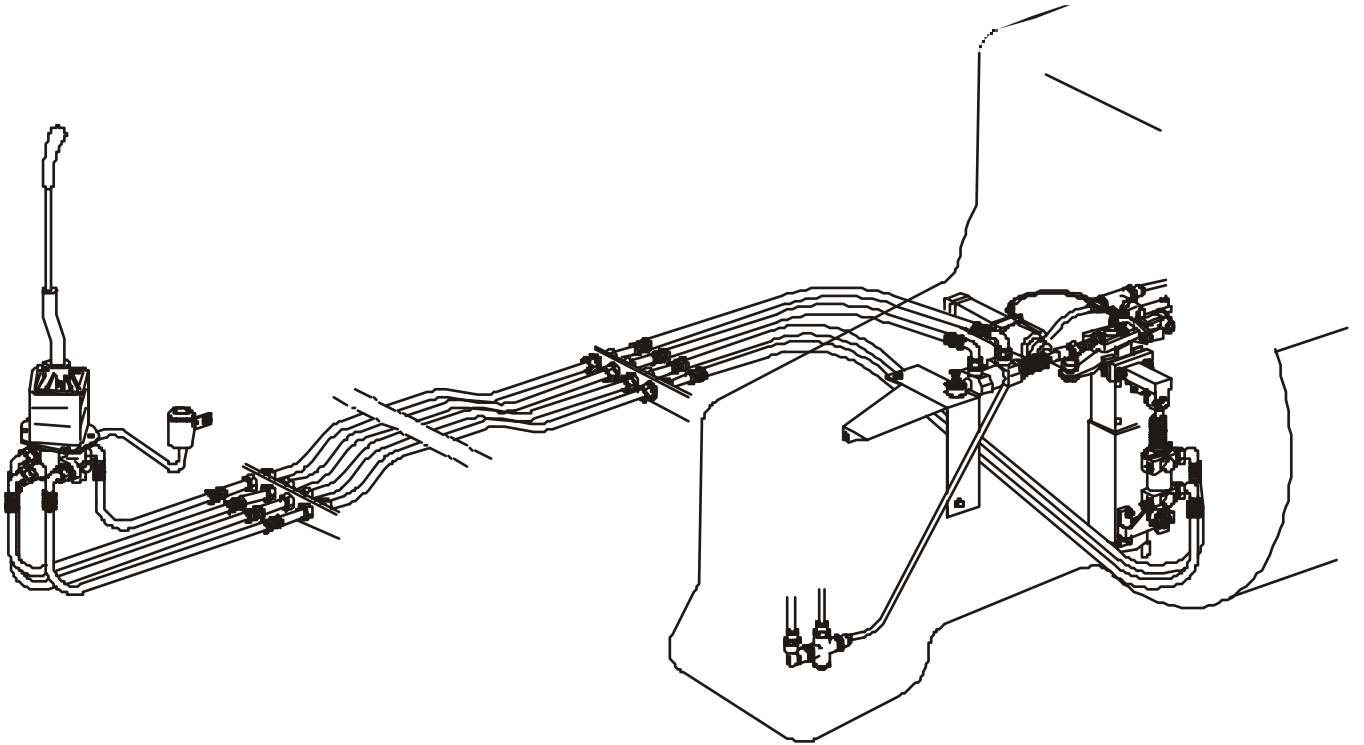

M10301

*Futura  
magis*

Autobusfabriek BOVA b.v.  
De Vest 9  
5555 XL Valkenswaard  
The Netherlands  
Phone: +31 (0) 40 2084611  
Fax: +31 (0) 40 2019477  
E-mail: [basis@bova.nl](mailto:basis@bova.nl)  
Website: [www.bova.nl](http://www.bova.nl)

Article: HGS SYSTEM

Version: 2.0/02-2003

Copyright © 2003 Autobusfabriek BOVA b.v., The Netherlands



# Table of contents

<b>1</b>	<b>Introduction</b> .....	<b>3</b>
<b>2</b>	<b>Safety instructions</b> .....	<b>4</b>
	2.1 General .....	4
	2.2 Specific .....	4
<b>3</b>	<b>Environmental information</b> .....	<b>5</b>
	3.1 General .....	5
	3.2 Specific .....	5
<b>4</b>	<b>System description</b> .....	<b>6</b>
	4.1 General .....	6
	4.1.1 Gear lever actuator (GLA).....	7
	4.1.2 Gearbox actuators (GBA).....	9
	4.2 Diagnosis.....	11
	4.2.1 Gear lever out of position.....	11
	4.2.2 Spongy gear lever .....	12
	4.2.3 Creeping gear lever.....	13
	4.2.4 Gear lever does not function after filling procedure.....	14
	4.2.5 Sudden malfunction in shift direction.....	15
	4.2.6 Mechanical malfunction in shift direction.....	16
	4.2.7 Sudden malfunction in select direction (sideways).....	17
	4.2.8 Mechanical malfunction in select direction (sideways) .....	18
<b>5</b>	<b>Repair and maintenance</b> .....	<b>19</b>
	5.1 General .....	19
	5.1.1 Special tools.....	19
	5.1.2 Gear lever actuator (GLA).....	20
	5.1.3 Gear box actuator (GBA).....	22
	5.2 Maintenance .....	24
<b>6</b>	<b>Filling/bleeding the system</b> .....	<b>25</b>
	6.1 Special tools .....	25
	6.2 Filling the system .....	25
	6.2.1 General.....	25
	6.2.2 Draining the system.....	26
	6.2.3 Filling/bleeding the system.....	28



# 1. Introduction

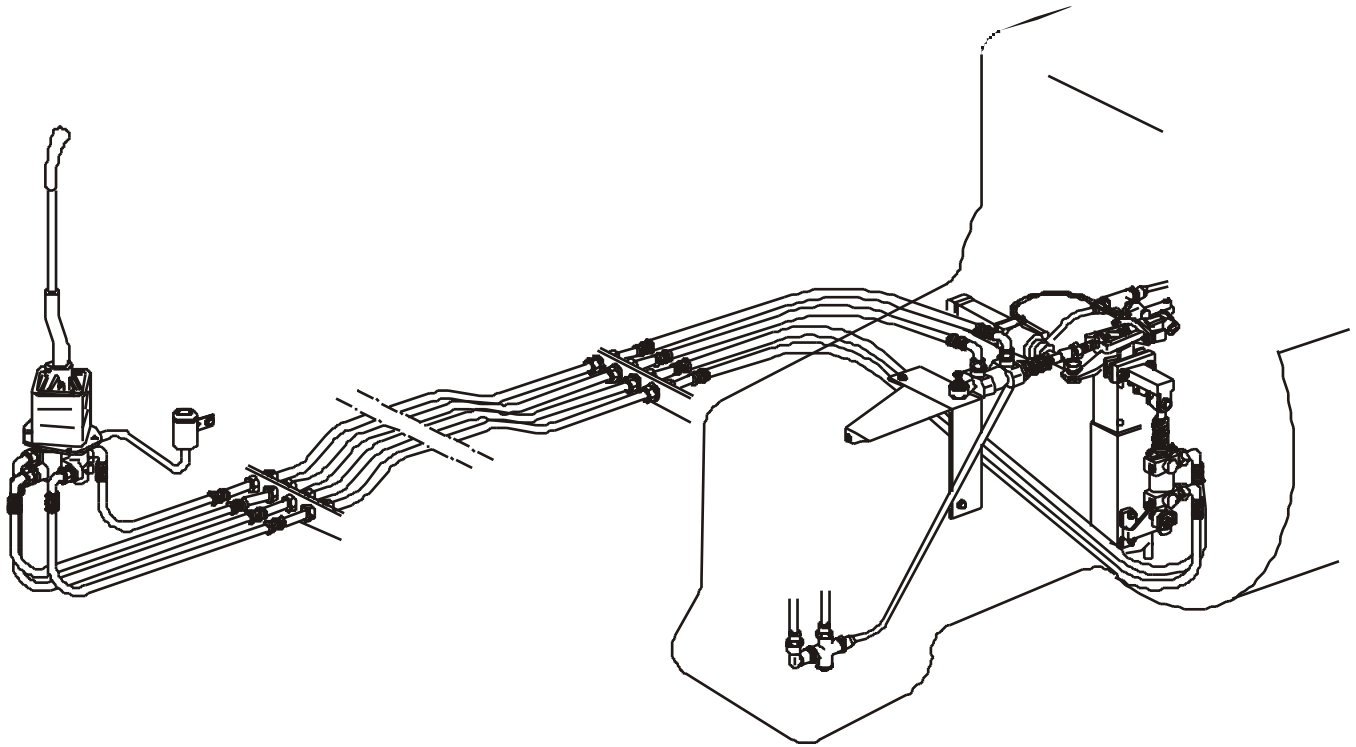

M10301

This workshop manual has been developed with the greatest possible care by Autobusfabriek BOVA b.v. It is intended as a source of information during fault finding and provides guidelines with regard to the replacement of parts.

Autobusfabriek BOVA b.v. however is not liable for any damage and/or costs arising from wrong or lacking data. Therefore, no rights can be derived from the workshop manual. Adjusting and test data may change due to technical developments and changing work methods. We, therefore, advise you to leave repairs to authorised BOVA dealers, whose practical and theoretical knowledge of the BOVA product is kept up to date by regular refresher courses.

A warranty, laid down in the locally valid sales and delivery conditions, applies to the repairs carried out by BOVA dealers. This warranty does not apply any longer when repairs have been carried out by personnel which

has not been trained by BOVA. Thus damage resulting from this and damage caused by the use of non-original parts will not be covered by our warranty.

This is a general description of the coach HGS (Hydraulic Gearshift System) system which is used in the BOVA Magiq and Futura. The hydraulic gearshift system is a manually operated gearshift system, which transfers gear-lever movement and force from the hand-operated gear lever, via hydraulic fluid along four hydraulic lines (hoses and pipes), to the gearbox. Because the HGS is a manual system, the forces required on the gear lever originate from the gearbox. For this reason, the gearbox determines the gear lever position. In case of a ZF 6S 1600 gearbox an air powered servo supports the movement in the shift direction.

The HGS system replaces mechanical linkage and cable shift systems.

## 2. Safety instructions

### 2.1 General

- When working on a BOVA coach always follow the safety instructions regarding the specific system.
- Only technicians trained and authorised by BOVA are allowed to work on BOVA products.
- Work carried out by non-authorised persons is dangerous and will affect the warranty.
- Always use durable tools and approved special tools.
- Always keep the workplace clean.
- Always guard personal safety.
- Always switch off the main switch and disconnect the battery clamps when working on parts of the electrical system.
- Protect the vehicle from rolling.

### 2.2 Specific

- Be alert to keep safe from moving parts.
- Always wear gloves to protect skin against oil and other fluid.
- Never use the same equipment for brake fluid and mineral oil based systems. The wrong grease or fluid will cause damage on rubber seals and o-rings.
- Don't fill the system with a mineral oil.
- Don't use mineral oil or grease for mounting purpose.
- Before filling or bleeding the system, check for the rubber caps on the bleed nipples. If the caps are not present, replace the bleed nipples to prevent contaminating the system
- After filling or bleeding the system, always reinstall the rubber caps on the bleed nipples.
- During welding on the vehicle don't use any part of the HGS system for a earthing point. Internal damage will occur.

# 3. Environmental information

## 3.1 General

- Always follow local environmental regulations.

## 3.2 Specific

- When cleaning or maintaining, e.g. filling the HGS system always follow local environmental regulations.
- Always read and follow the instructions on products used while cleaning or maintaining.
- Dispose of waste according to local environmental regulations.

# 4. System description

## 4.1 General

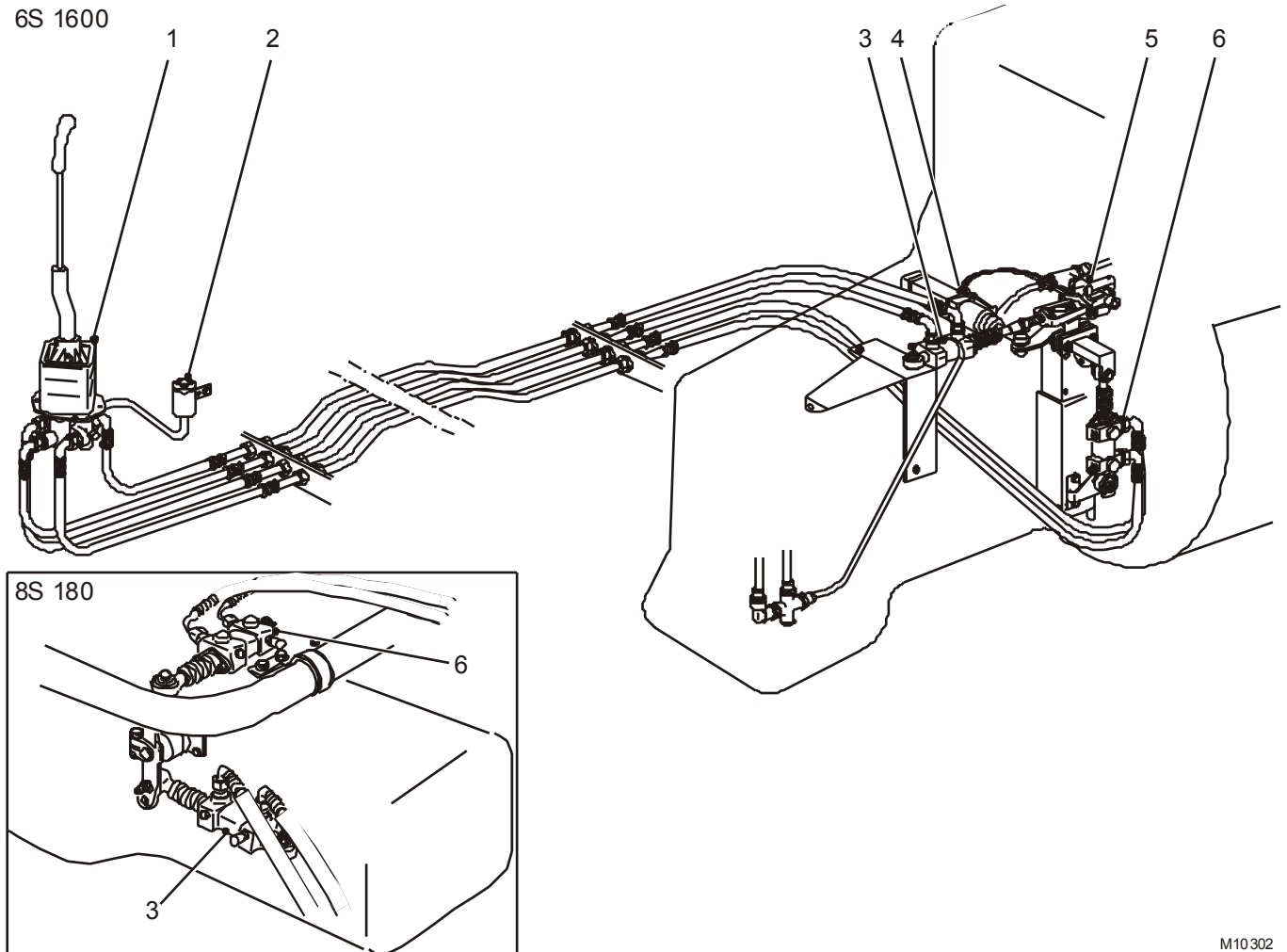

M10 302

- 1 Gear lever actuator (GLA)
- 2 Fluid reservoir
- 3 GearBox Actuator (GBA) shift cylinder
- 4 Shift servo cylinder
- 5 Shift servo actuator
- 6 GearBox Actuator (GBA) select cylinder

The gear lever is attached to the GLA (1). The GLA converts gear-lever forces and movements into hydraulic pressures and into fluid flows. Four pistons in cylinders, create the hydraulic pressure and the fluid flow. If you move the gear lever forward, the front piston transfers the force and the movement. If you move the gear lever backwards, the rear piston transfers the force and the movement. If you move the gear lever to the left-hand side, the left piston transfers the force and the movement. If you move the gear lever to the right-hand side, the right piston transfers the force and the movement.

In the middle of the actuator you find the working reservoir connected to the pistons.

The required forces on the gearbox come from the 2 GBA's (select-, en shift cilinder) on the gearbox. When pushing the lever to left or right, the hydraulic fluid will move the piston of the gearbox select cylinder (6) up or down and will select a gear. When pushing the lever to the front or rear, the piston of the gearbox shift cylinder (3) will go to the rear or front and will switch in the selected gear, or in case of a ZF 6S 1600 gearbox operate the shift servo actuator (5) which operates the shift servo cylinder (4). The shift servo cylinder actually switches in the selected gear.



### 4.1.1 Gear lever actuator (GLA)

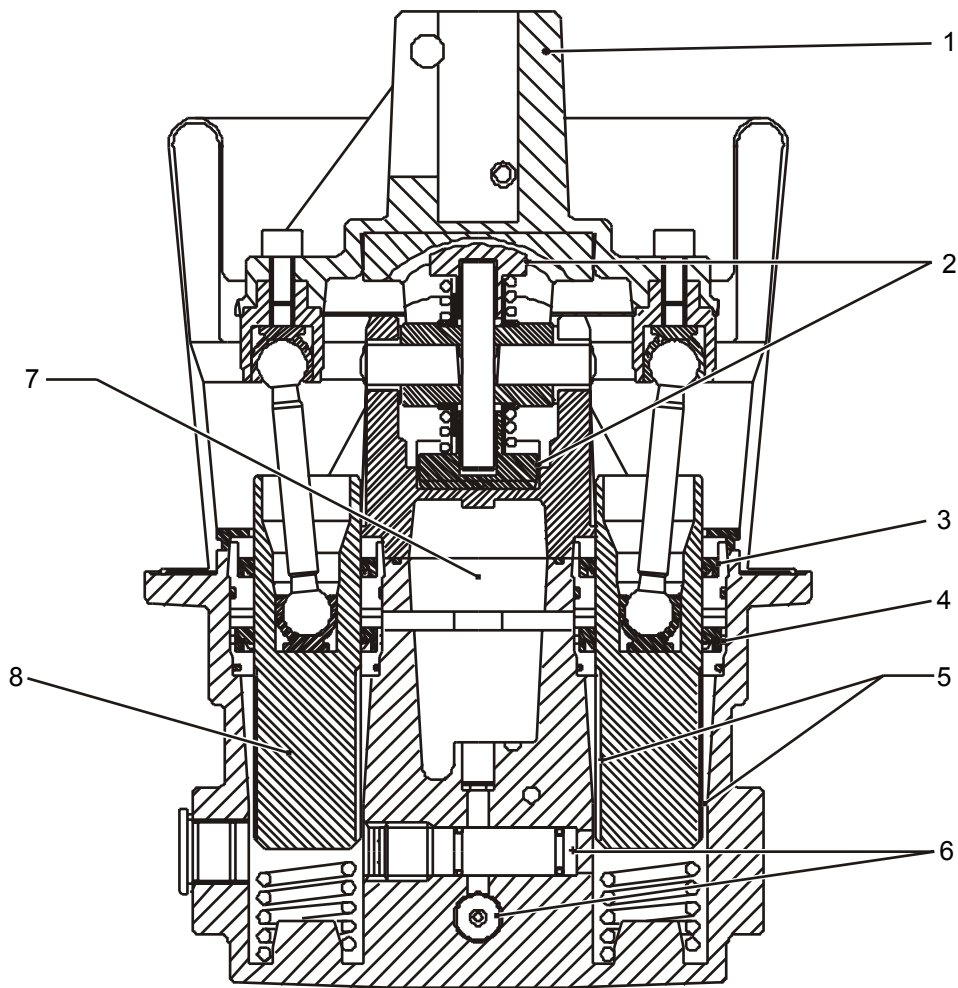

M10303

- |   |                |   |   |
|---|----------------|---|---|
| 1 | Gear lever     | 5 | Axial grooves                             |
| 2 | Locking device | 6 | Double-acting pressure relief valve (DPR) |
| 3 | Upper seal     | 7 | Reservoir                                 |
| 4 | Lower seal     | 8 | Piston                                    |

In the GLA there are four pistons (8). Two for the shift circuit and two for the select circuit. The pistons in each circuit have different diameters. This is to compensate the difference of the volume between left and right of the pistons in the shift-, and the select cylinder. This compensation takes care that the moved volume at the GLA and the volume on both sides in the shift and select cylinder is the same.

One of the basic principles of the HGS system is the self-adjusting principle in the GLA. The self-adjusting function resets the gear lever position if the position does not correspond to the select gear in the gearbox. The combination of the following items enable the self-adjusting function: axial grooves (5) of a defined length on the piston, the position of the lower seals (4) and their one-way valve function.

The design lets the axial grooves on the pistons just reach the lower seal in a normal outer position. If for any reason, the gear lever is out of the normal outer position, the grooves on the piston will go above the lower seal. The grooves open the connection between the hydraulic system and the reservoir (7). If you move the gear lever back, the first movement is just an adjustment, the following occurs:

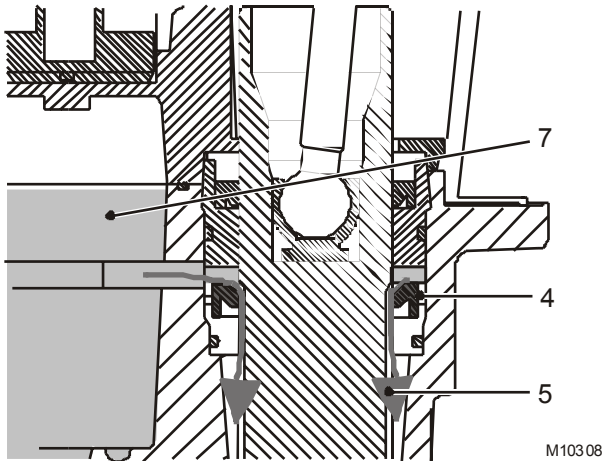

M103 08

- Fluid is moved from one of the circuits over the grooves (5) to the reservoir (7).
- Fluid flows from the reservoir (7) to the opposite circuit over the one-way valve lip of the lower seal (4).

The self-adjusting principle makes sure that the gear lever is always in the correct position, regardless of temperature variations and regardless of small leakage.

**Locking device**

The gear lever can drift because:

- There is pressure change due to increase in temperature.
- There is a pressure drop due to a leakage.
- The weight of the gear lever itself.

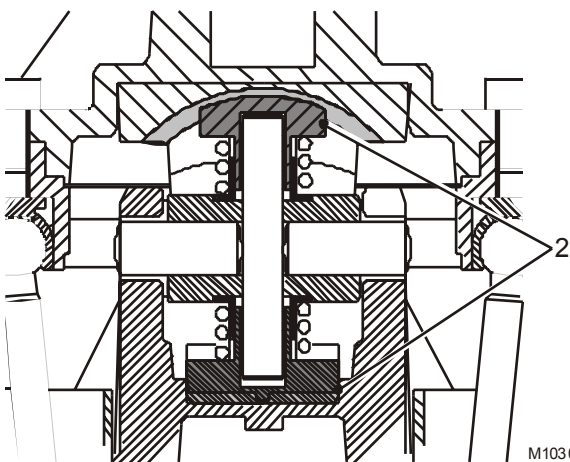

M103 06

Inside of the Gear Lever Actuator (GLA) there is a locking device (2) to prevent the gear lever from drifting out of position.

The locking device is not intended to give the driver the feeling of engaging gears, it is the shift mechanism in the gearbox which determines that.

**Double-acting pressure relief valve**

The GLA also contains two double-acting pressure relief valves (DPR) (6) that compensate for fluid expansion when the pressure increases due to a higher temperature. One important aspect of the operating principle of these valves is that the valve does not open at the side of the piston which pressurizes the circuit when the driver is operating the GLA. When the pressure is too high, the DPR only opens at the side of the piston which is non operational.

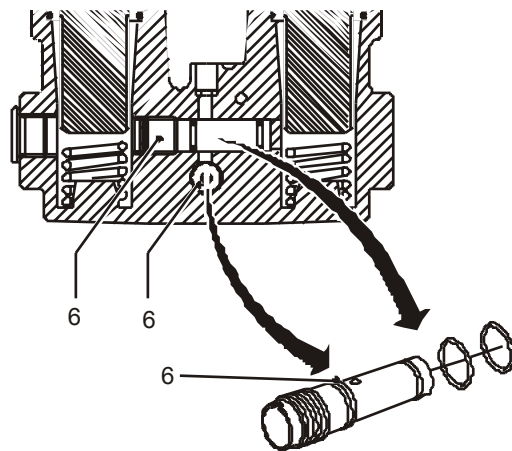

M1 030 4

## 4.1.2 Gearbox actuators (GBA)

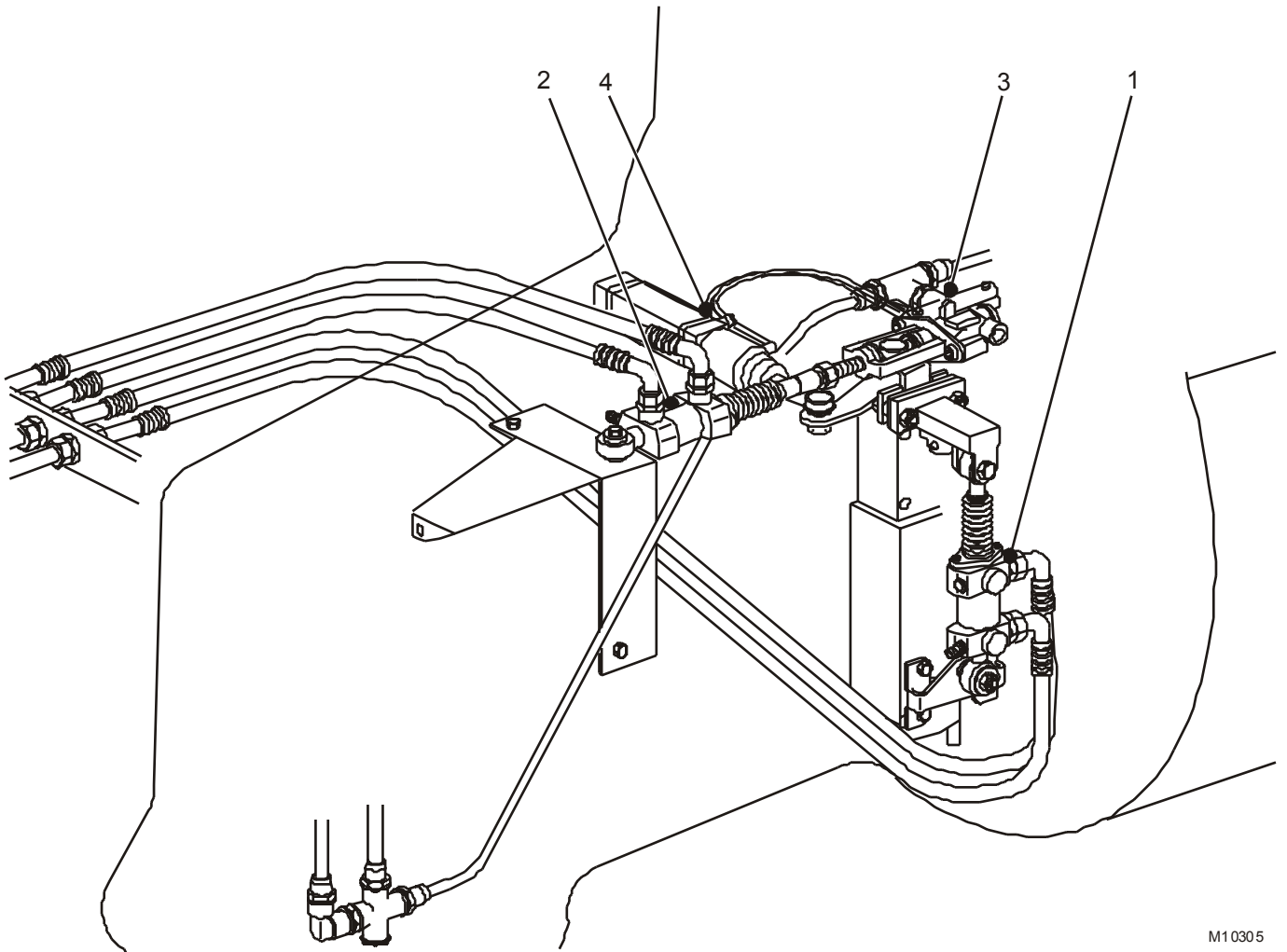

M10305

- 1 Gearbox select cylinder
- 2 Gearbox shift cylinder

- 3 Shift servo actuator
- 4 Shift servo cylinder

### **Gearbox select cylinder**

The select cylinder converts hydraulic pressure and fluid flow to the required mechanical force and to the movement on the gear-box shift shaft.

The select cylinder (1) pulls and pushes the shift shaft in the axial direction, in order to select which gear to shift. The select cylinder is a normal double-acting hydraulic cylinder. The select cylinder is connected to the respective cylinders on the GLA, by hoses, which make it a circuit.

### **Gearbox shift cylinder**

The shift cylinder converts hydraulic pressure and fluid flow to the required mechanical force and to the movement on the gear-box shift shaft.

The shift cylinder (2) pulls and pushes to rotate the shift shaft in both directions in order to shift the gear.

The shift cylinder is a normal double-acting hydraulic cylinder. The shift cylinder is connected to the respective cylinders on the GLA, by hoses, which make it a circuit.

### **Shift servo actuator**

In case of a ZF 6S 1600 gearbox the shift cylinder operates the shift servo actuator (3). The servo actuator is a pneumatic valve which operates, at the command of the gearbox shift cylinder, the shift servo cylinder (4).

### **Shift servo cylinder**

The shift servo cylinder is a pneumatic cylinder which actually switches in the selected gear.

### Shift-, and select cylinder

The shift-, and select cylinder are in fact both the same. The only difference is the location of the connection of the hoses and the connection to the shift shaft.

The cylinder has a special bleed nipple (1) and a bleed plug (2). An O-ring on the bleed nipple and on the bleed plug prevent air or fluid leakage if filling or bleeding the system.

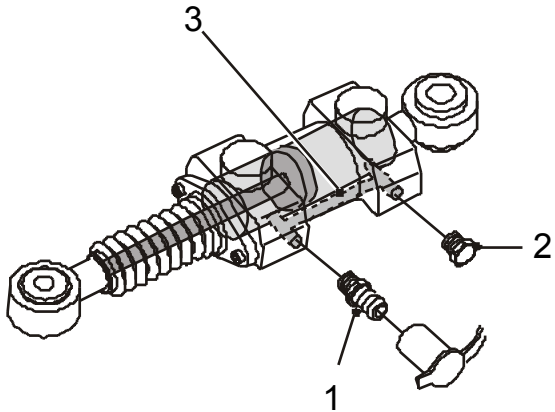

M103 07

An axial cross bore (3) between the two nipples connects the bleed plug to the bleed nipple.



**Note: If you close the bleed nipple, there is still a connection to the bleed plug via the axial bore. This lets you fill both sides of the system trough the bleed nipple.**

## 4.2 Diagnosis

### 4.2.1 Gear lever out of position

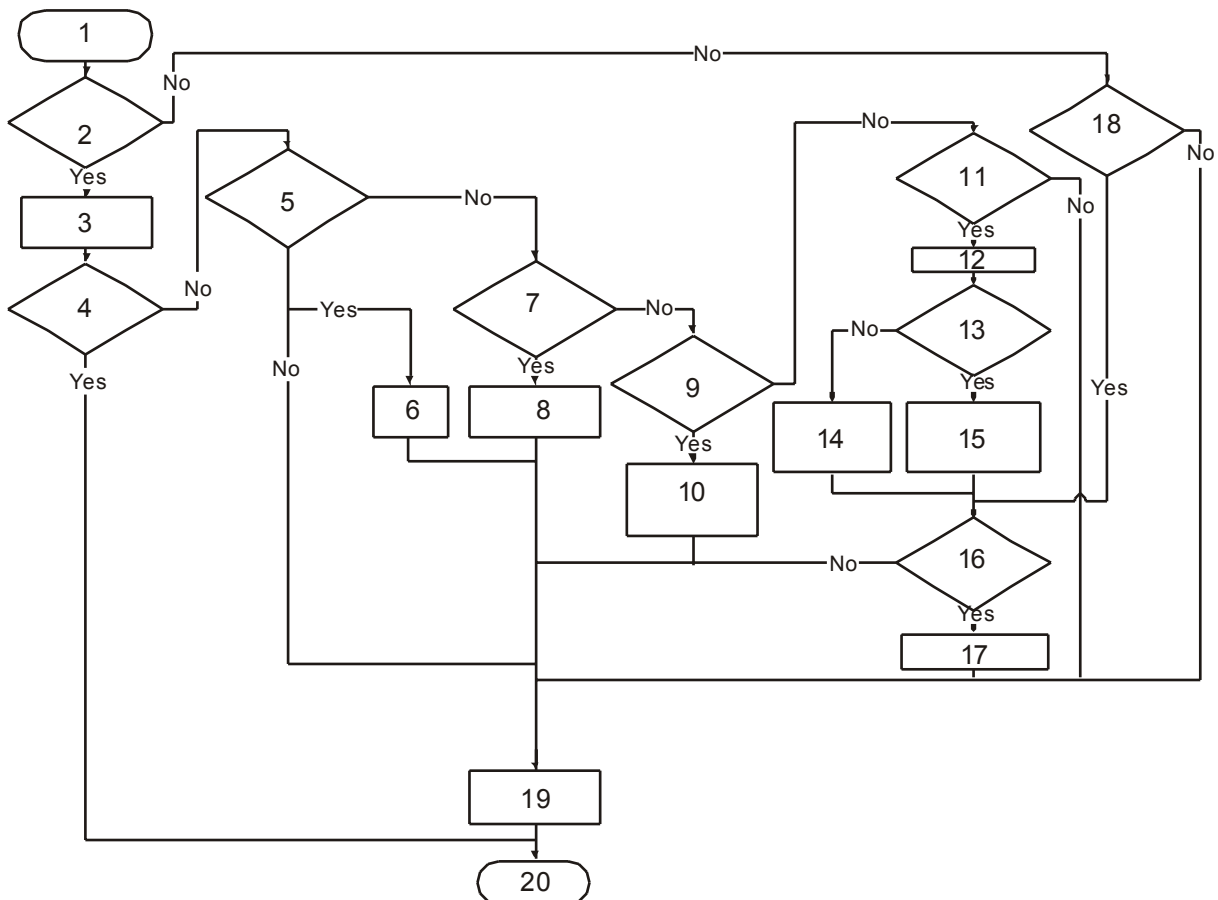

M10 309

- |  |   |
|--|---|
| 1 Gear lever is out of position                        | 11 Is there a leakage on top of the GLA?              |
| 2 Did error occur while driving the vehicle?           | 12 Disassemble GLA                                    |
| 3 Try to adjust gear lever according to description    | 13 Are pistons worn or damaged?                       |
| 4 Does gear lever hold position now?                   | 14 Repair GLA with seal case and DPR valve repair kit |
| 5 Is there a leakage in the tubes or hoses connection? | 15 Repair GLA with piston-, and seal case repair kit  |
| 6 Replace leaking part                                 | 16 Is the locking force in GLU too low?               |
| 7 Are the GBA bleed nipples leaking or damaged?        | 17 Replace GLU  |
| 8 Replace bleed nipples and tighten with 8 Nm          | 18 Did error occur after parking the vehicle?         |
| 9 Is there leakage around the GBA push rod?            | 19 Refill with fluid and bleed the system             |
| 10 Replace the GBA according to description            | 20 Check whether error is repaired                    |

#### Explanation of abbreviations

- GLA: Gear Lever Actuator
- GLU: Gear Lever Unit
- GBA: GearBox Actuator



**Use only OEM rubber seals or O-rings. Incorrect rubber materials will cause a breakdown of the HGS system.**

## 4.2.2 Spongy gear lever

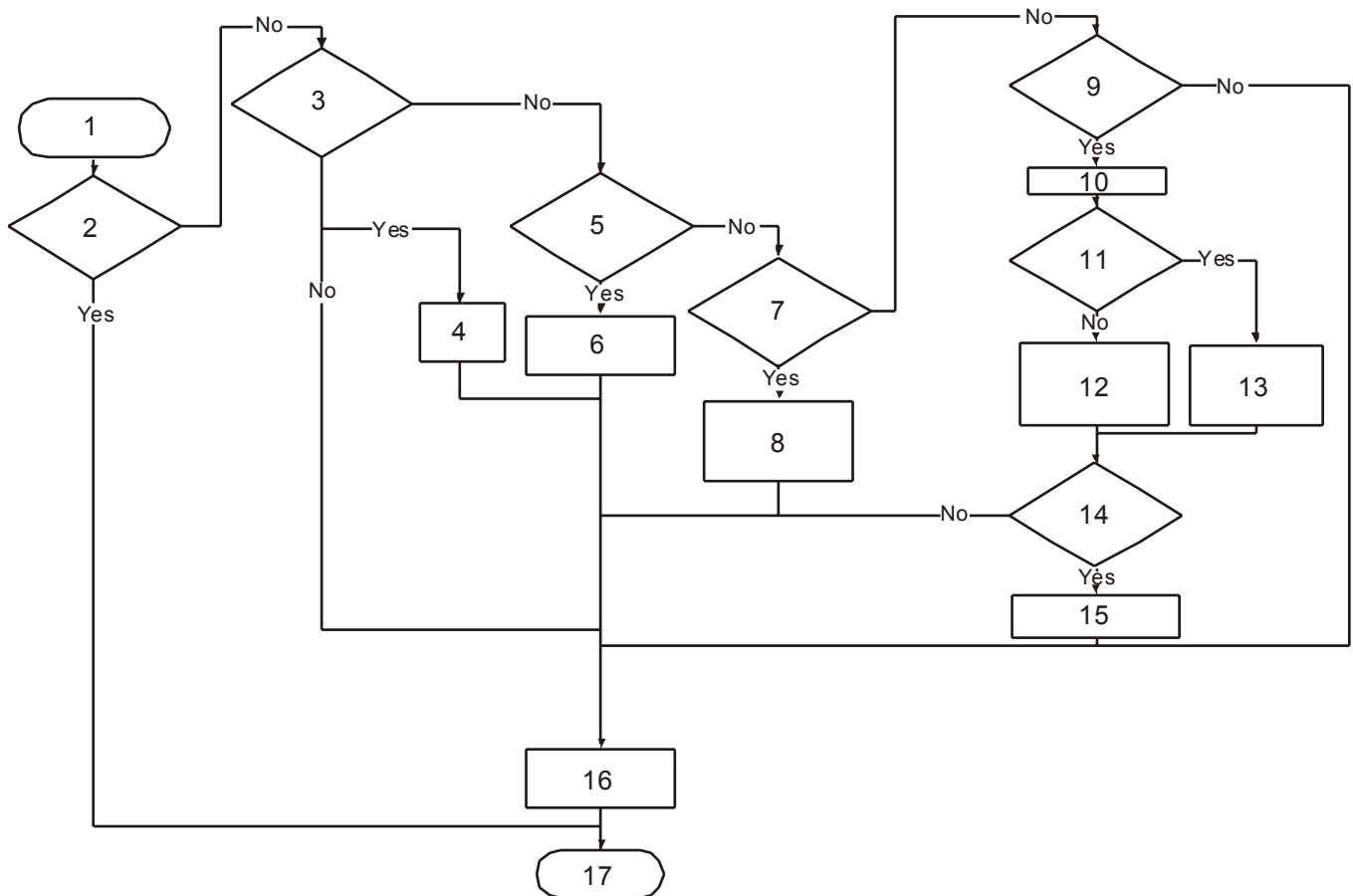

M103 10

- |  |   |
|--|---|
| 1 Spongy gear lever jumps back while changing gear   | 10 Disassemble GLA                                    |
| 2 Is there enough fluid in the reservoir?            | 11 Are pistons worn or damaged?                       |
| 3 Is there leakage in the tubes or hoses connection? | 12 Repair GLA with seal case and DPR valve repair kit |
| 4 Replace the leaking part                           | 13 Repair GLA with piston-, and seal case repair kit  |
| 5 Are the GBA bleed nipples leaking or damaged?      | 14 Is the locking force in GLU too low?               |
| 6 Replace bleed nipples and tighten to 8 Nm          | 15 Replace GLU  |
| 7 Is there leakage around the GBA push rod?          | 16 Refill with fluid and bleed the system             |
| 8 Replace GBA according to description               | 17 Check whether error is repaired                    |
| 9 Is there a leakage on top of the GLA?              |   |

### Explanation of abbreviations

- GLA: Gear Lever Actuator
- GLU: Gear Lever Unit
- GBA: GearBox Actuator



**Use only OEM rubber seals or O-rings. Incorrect rubber materials will cause a breakdown of the HGS system.**

### 4.2.3 Creeping gear lever

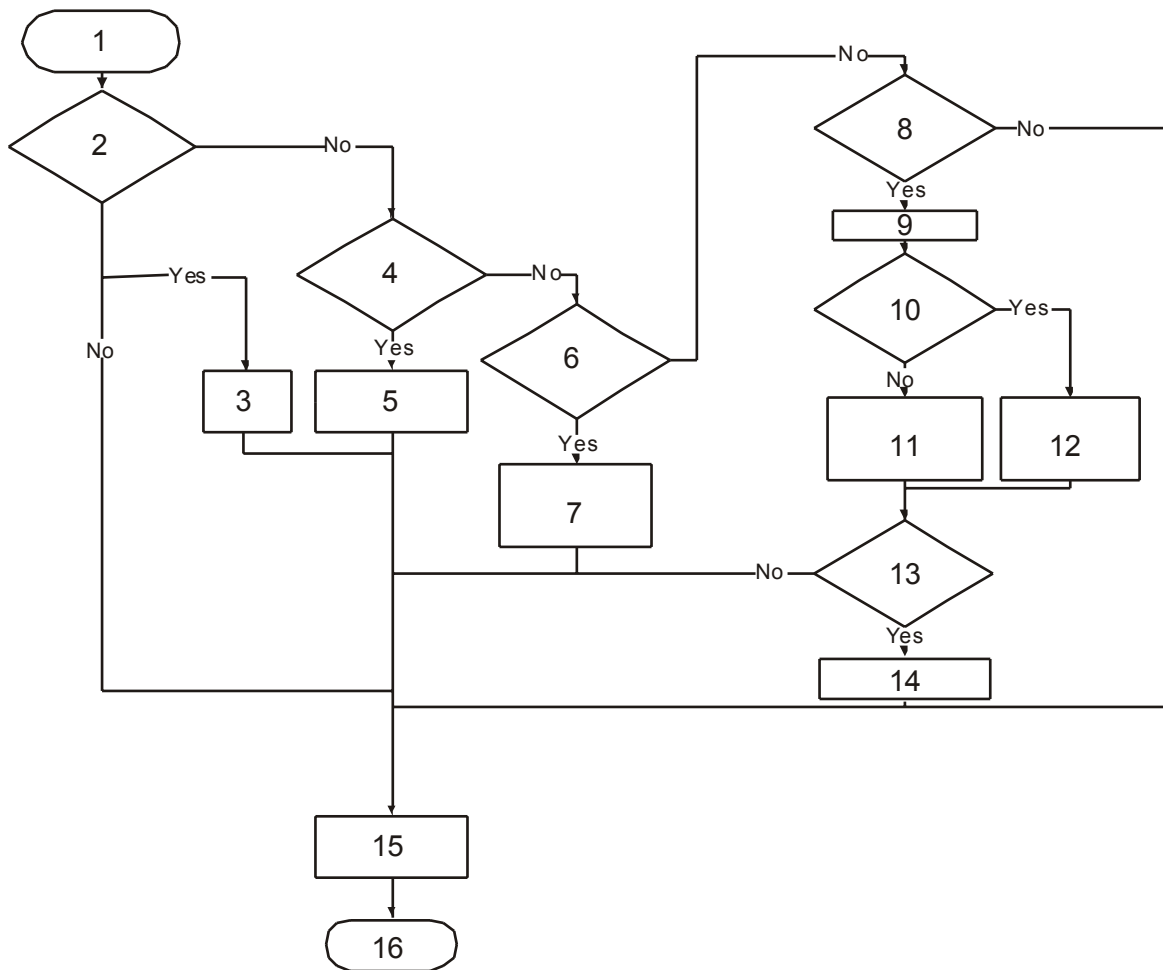

M10311

- |  |   |
|--|---|
| 1 Creeping gear lever                                | 9 Disassemble GLA                                     |
| 2 Is there leakage in the tubes or hoses connection? | 10 Are pistons worn or damaged?                       |
| 3 Replace the leaking part                           | 11 Repair GLA with seal case and DPR valve repair kit |
| 4 Are the GBA bleed nipples leaking or damaged?      | 12 Repair GLA with piston-, and seal case repair kit  |
| 5 Replace bleed nipples and tighten to 8 Nm          | 13 Is the locking force in GLU too low?               |
| 6 Is there leakage around the GBA push rod?          | 14 Replace GLU  |
| 7 Replace GBA according to description               | 15 Refill with fluid and bleed the system             |
| 8 Is there a leakage on top of the GLA?              | 16 Check whether error is repaired                    |

#### Explanation of abbreviations

- GLA: Gear Lever Actuator
- GLU: Gear Lever Unit
- GBA: GearBox Actuator



**Use only OEM rubber seals or O-rings. Incorrect rubber materials will cause a breakdown of the HGS system.**

#### 4.2.4 Gear lever does not function after filling procedure

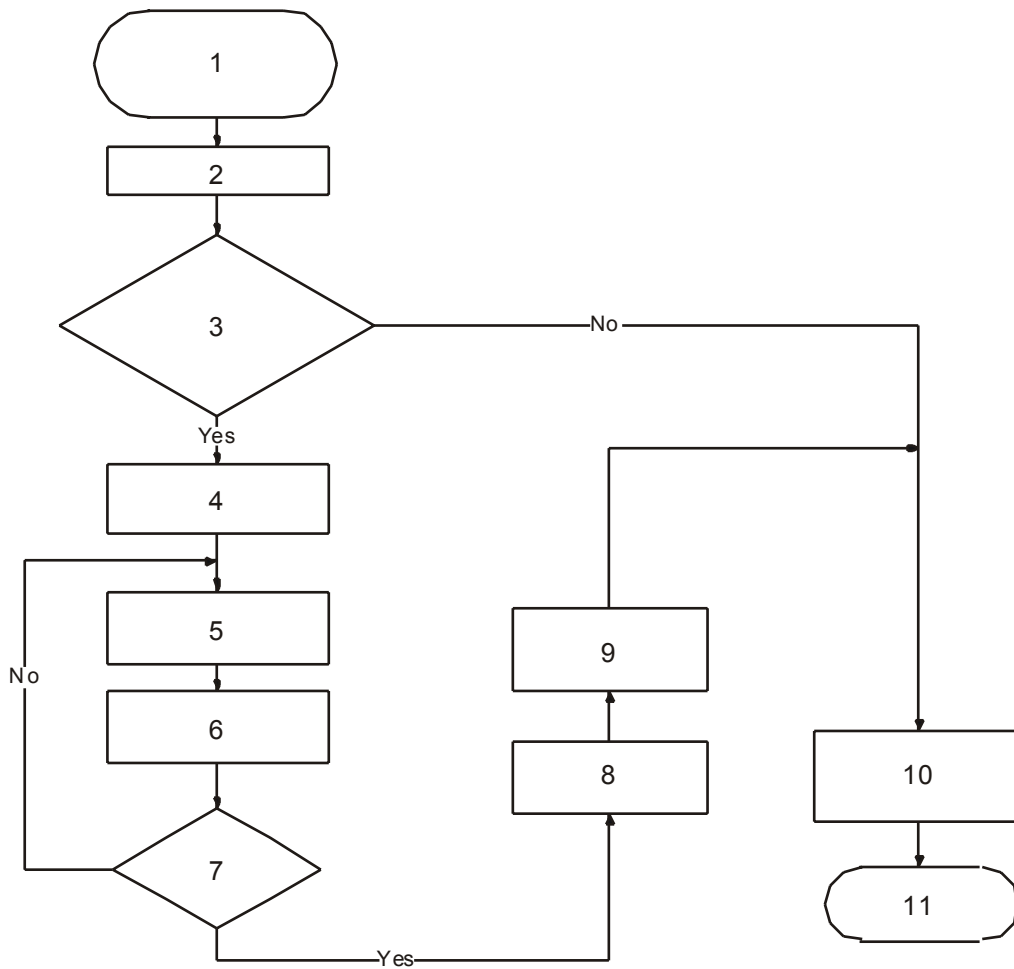

M10312

- |  |  |
|--|--|
| <p><b>1</b> Gear lever does not work at all in either of the directions after filling</p> <p><b>2</b> Read filling procedure thoroughly</p> <p><b>3</b> Is system filled faulty by pressurising reservoir instead of GBA nipples?</p> <p><b>4</b> Disassemble GLA and take out DPR valves according to description</p> <p><b>5</b> Knock DPR valves on a hard and clean surface</p> <p><b>6</b> Shake DPR valves and listen if pin inside is loose</p> | <p><b>7</b> Is the pin inside the DPR valve loose?</p> <p><b>8</b> Reinstall the DPR valves according to description</p> <p><b>9</b> Reinstall the GLA into system according to description</p> <p><b>10</b> Refill with fluid and bleed the system</p> <p><b>11</b> Check whether error is repaired</p> |
|--|--|

#### Explanation of abbreviations

- GLA: Gear Lever Actuator
- GLU: Gear Lever Unit
- GBA: GearBox Actuator



**Use only OEM rubber seals or O-rings. Incorrect rubber materials will cause a breakdown of the HGS system.**



## 4.2.5 Sudden malfunction in shift direction

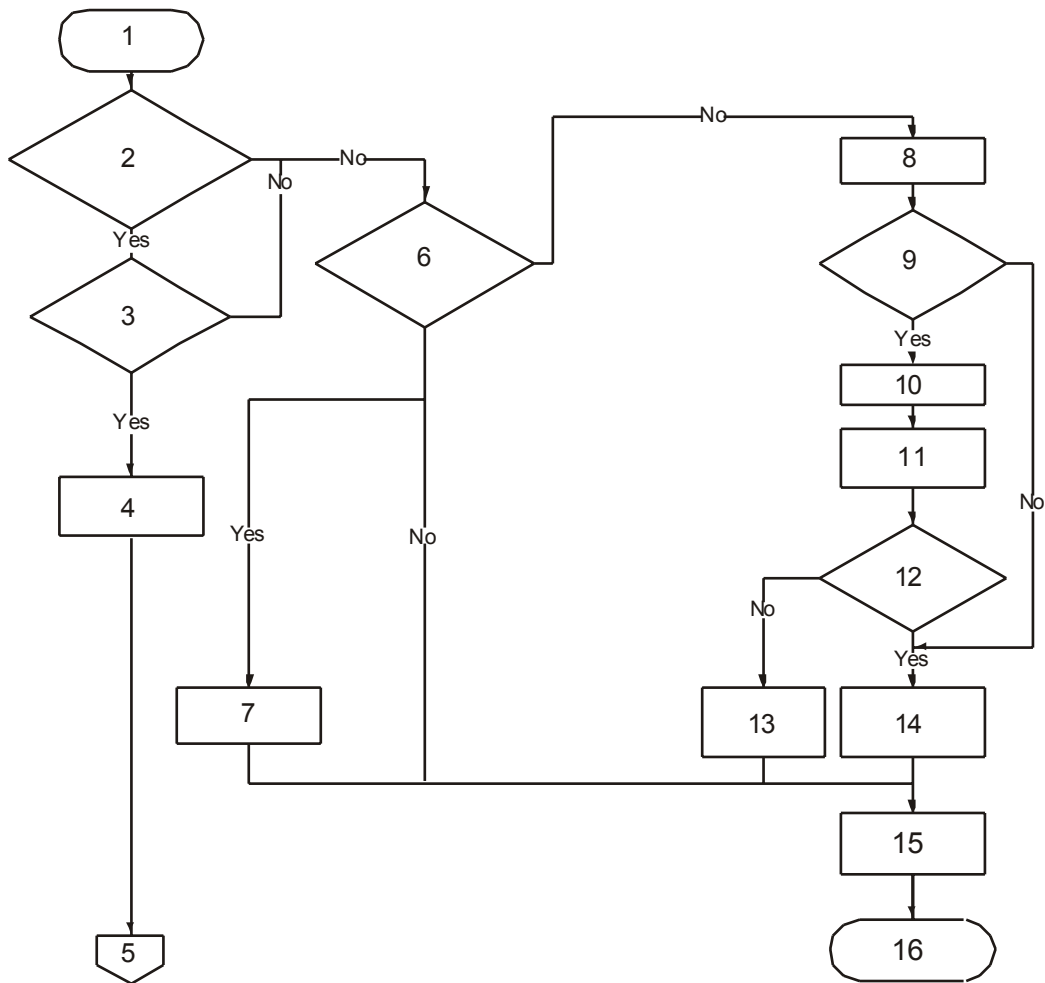

M10313

- |   |  |
|---|--|
| <p><b>1</b> Sudden malfunction in shift direction</p> <p><b>2</b> Can the gear lever be moved both forwards and backwards without resistance?</p> <p><b>3</b> Is there enough fluid in the reservoir?</p> <p><b>4</b> Mechanical error at shift GBA or gearbox</p> <p><b>5</b> Go to 1 of 4.2.6 on page 16</p> <p><b>6</b> Is there a leakage in the tubes or hoses connection?</p> <p><b>7</b> Replace the leaking part</p> <p><b>8</b> Remove the GLA bellow (gear shift rod cover)</p> | <p><b>9</b> Are all push rod connections (4x) O.K.?</p> <p><b>10</b> Internal hydraulic leakage in GLA</p> <p><b>11</b> Open GLA according to description</p> <p><b>12</b> Are push rods or pistons worn or damaged?</p> <p><b>13</b> Repair GLA with seal case and DPR valve repair kit</p> <p><b>14</b> Repair GLA with piston-, and seal case repair kit</p> <p><b>15</b> Refill with fluid and bleed the system</p> <p><b>16</b> Check whether error is repaired</p> |
|---|--|

### Explanation of abbreviations

- GLA: Gear Lever Actuator
- GLU: Gear Lever Unit
- GBA: GearBox Actuator



**Use only OEM rubber seals or O-rings. Incorrect rubber materials will cause a breakdown of the HGS system.**

## 4.2.6 Mechanical malfunction in shift direction

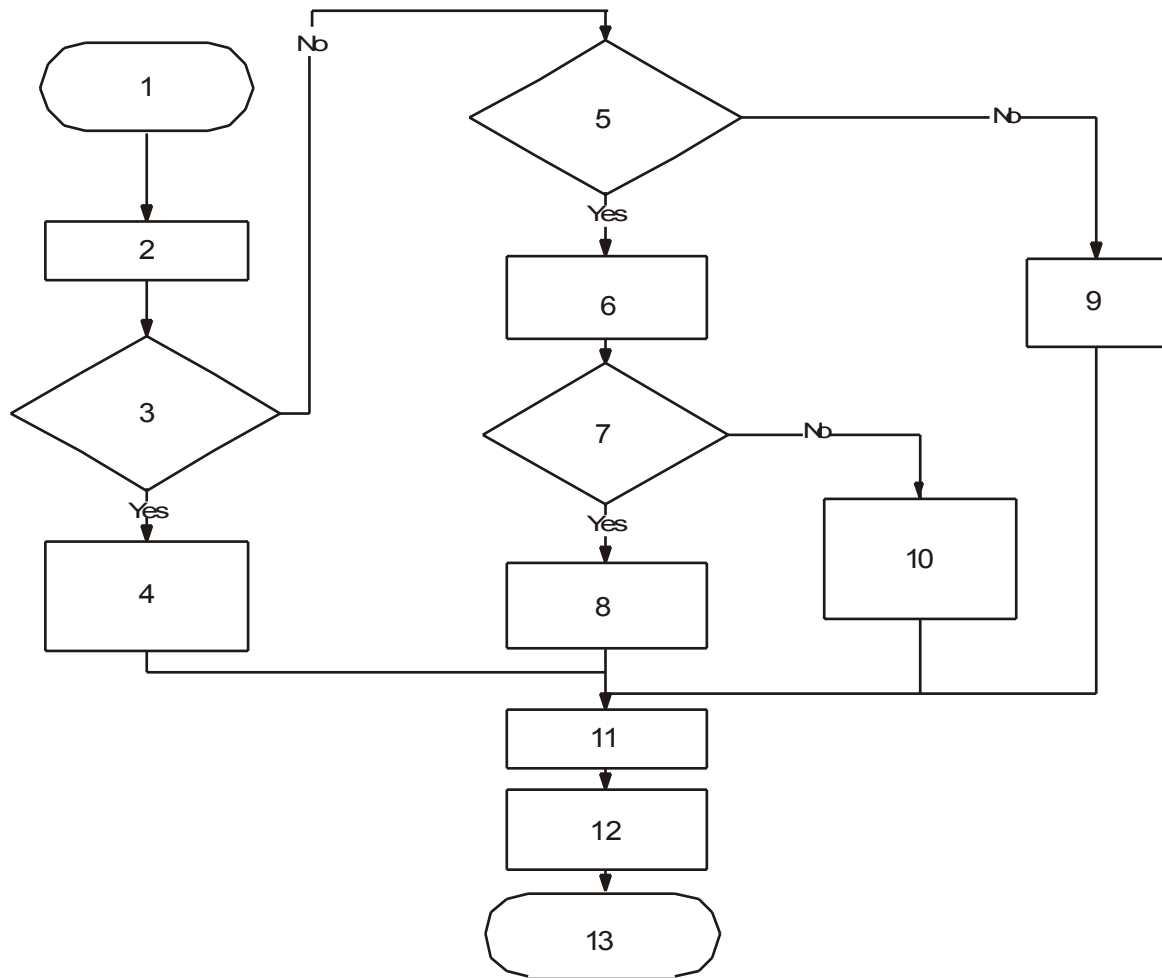

M10314

- |   |   |
|---|---|
| 1 Mechanical error at shift GBA or gearbox  | 8 Repair error on the gearbox               |
| 2 Disassemble the shift GBA from gearbox    | 9 Reinstall push rod connection             |
| 3 Is the push rod loose or broken?          | 10 Replace the GBA according to description |
| 4 Replace the GBA according to description  | 11 Install GBA onto gearbox                 |
| 5 Is the push rod connected to the gearbox? | 12 Refill with fluid and bleed the system   |
| 6 Move the gear lever                       | 13 Check whether error is repaired          |
| 7 Does the shift push rod move?             |   |

### Explanation of abbreviations

- GLA: Gear Lever Actuator
- GLU: Gear Lever Unit
- GBA: GearBox Actuator



**Use only OEM rubber seals or O-rings. Incorrect rubber materials will cause a breakdown of the HGS system.**

## 4.2.7 Sudden malfunction in select direction (sideways)

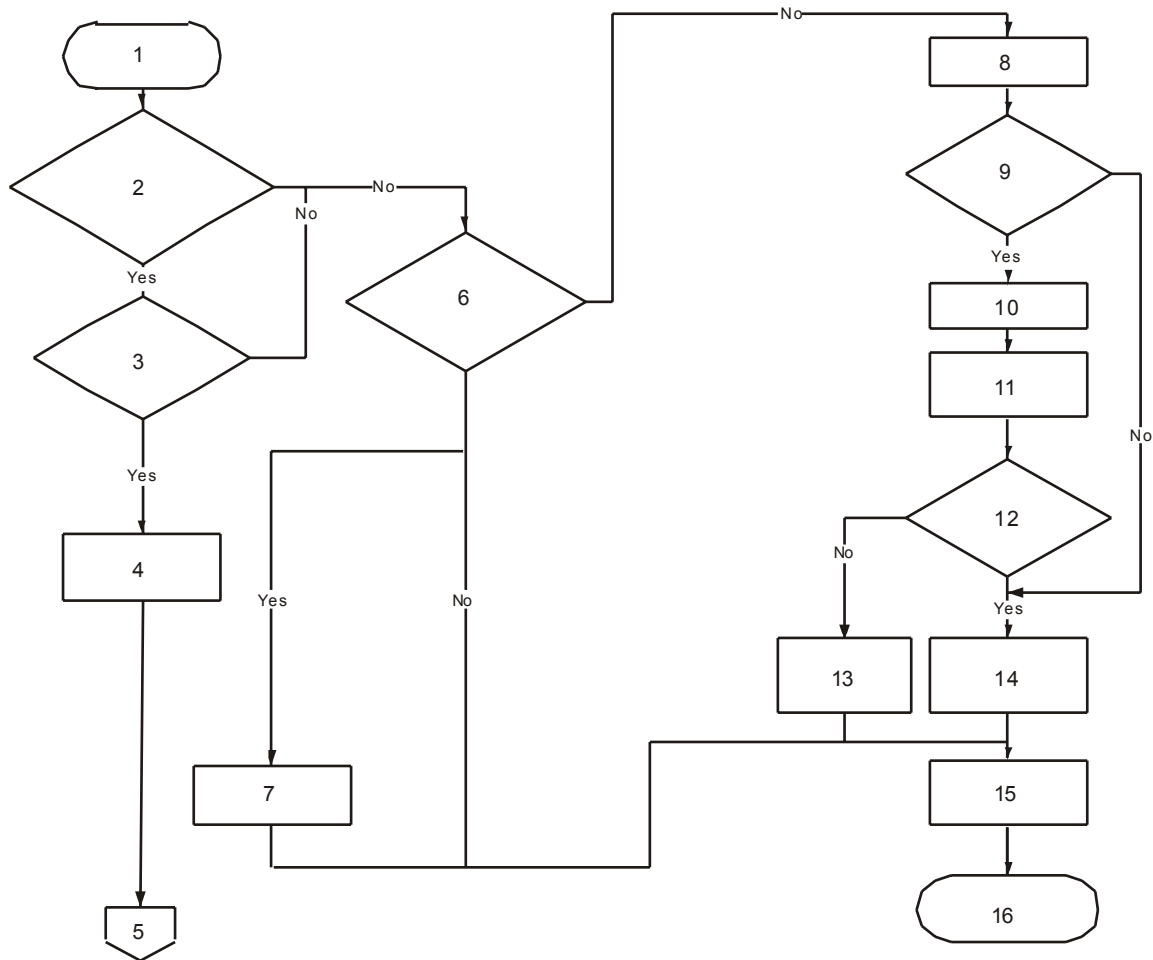

M10315

- |  |  |
|--|--|
| <p><b>1</b> Sudden malfunction in select direction</p> <p><b>2</b> Can the gear lever be moved left/right without resistance?</p> <p><b>3</b> Is there enough fluid in the reservoir?</p> <p><b>4</b> Mechanical error at select GBA or gearbox</p> <p><b>5</b> Go to 2 of 4.2.6 on page 16</p> <p><b>6</b> Is there leakage in the tubes or hoses connections?</p> <p><b>7</b> Replace the leaking part</p> <p><b>8</b> Remove GLA bellow</p> | <p><b>9</b> Are all push rod connections (4x) O.K.?</p> <p><b>10</b> Internal hydraulic leakage in GLA</p> <p><b>11</b> Open GLA according to description</p> <p><b>12</b> Are push rods or pistons worn or damaged?</p> <p><b>13</b> Repair GLA with seal case and DPR valve repair kit</p> <p><b>14</b> Repair GLA with piston-, and seal case repair kit</p> <p><b>15</b> Refill with fluid and bleed the system</p> <p><b>16</b> Check whether error is repaired</p> |
|--|--|

### Explanation of abbreviations

- GLA: Gear Lever Actuator
- GLU: Gear Lever Unit
- GBA: GearBox Actuator



**Use only OEM rubber seals or O-rings. Incorrect rubber materials will cause a breakdown of the HGS system.**

## 4.2.8 Mechanical malfunction in select direction (sideways)

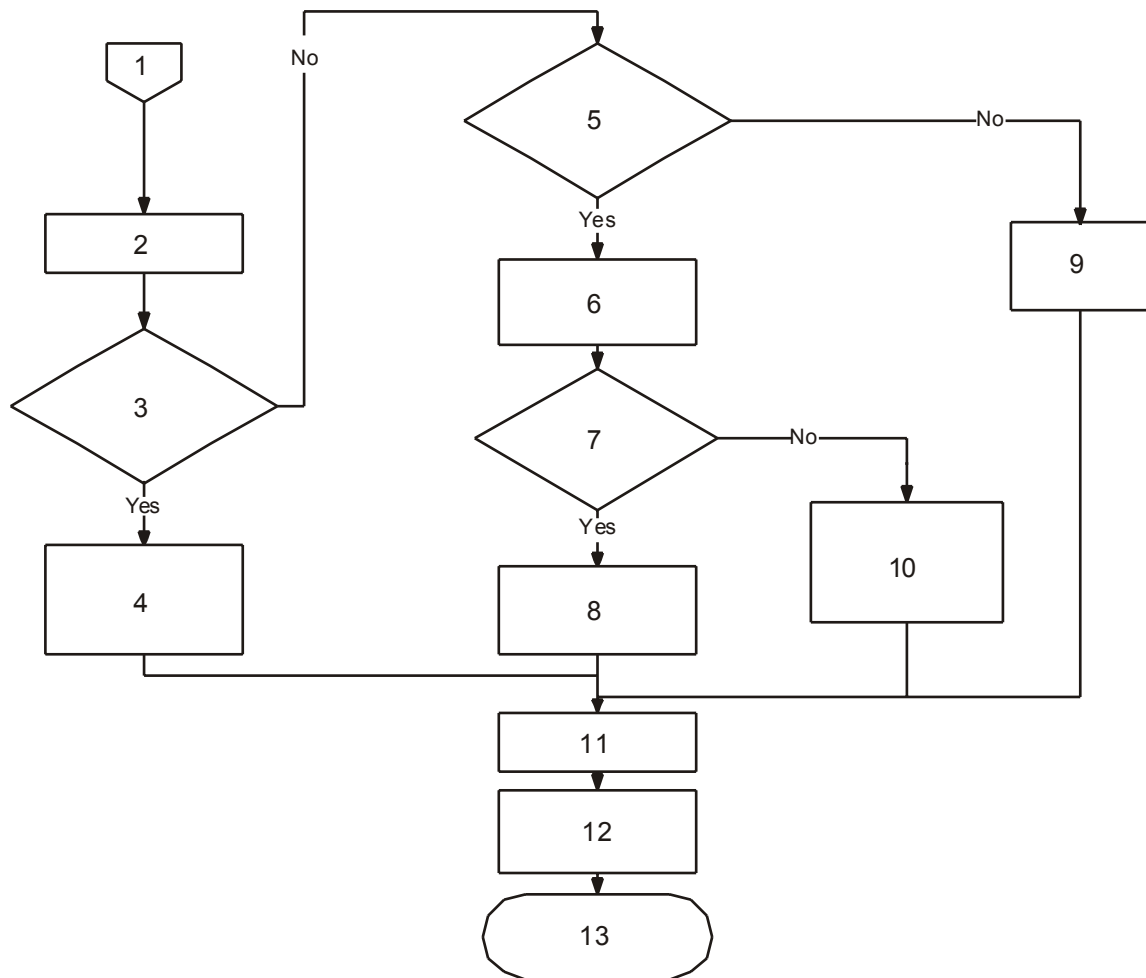

M10316

- |   |   |    |  |
|---|---|----|--|
| 1 | Mechanical error at select GBA or gearbox | 8  | Repair error on the gearbox              |
| 2 | Remove select GBA from the gearbox        | 9  | Reinstall push rod connection            |
| 3 | Is the push rod loose or broken?          | 10 | Replace the GBA according to description |
| 4 | Replace GBA according to description      | 11 | Install GBA onto gearbox                 |
| 5 | Is the push rod connected to the gearbox? | 12 | Refill with fluid and bleed the system   |
| 6 | Move the gear lever                       | 13 | Check whether error is repaired          |
| 7 | Does the select push rod move?            |    |  |

### Explanation of abbreviations

- GLA: Gear Lever Actuator
- GLU: Gear Lever Unit
- GBA: GearBox Actuator



**Use only OEM rubber seals or O-rings. Incorrect rubber materials will cause a breakdown of the HGS system.**

# 5. Repair and maintenance

## 5.1 General



Never use mineral oil or grease to lubricate the seals and rubber parts. These are made from EPDM rubber, and even microscopic particles of mineral oil or grease can cause swelling of these rubber, and with that the breakdown of the system.



Always wear gloves to protect skin against oil and other fluid. Never use fingers to check the fluid level in the reservoir.



Never use used oil cans to fill up the system and never fill up the system with used brake fluid.

### 5.1.1 Special tools

Use the following special tools to remove and install the repair kits:

1. DPR valve tool
2. Seal case extraction tool, Kuko 21/4 20-30 mm
3. Quick connector for filling and bleeding procedure
4. Quick connector release tool

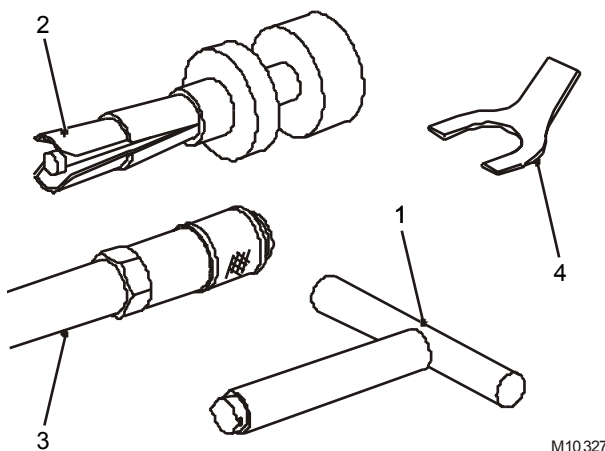

## 5.1.2 Gear lever actuator (GLA)

### Removal

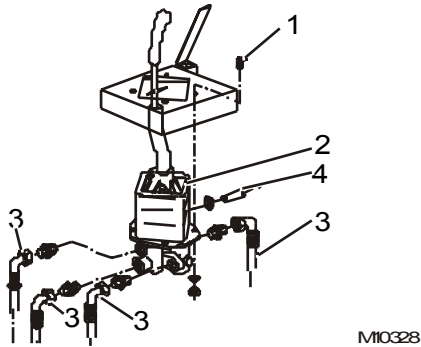

1. Drain the system.
2. Remove the gear shift rod cover in the drivers compartment.
3. Remove the hoses (3) from the GLA.
4. Remove the reservoir hose (4) from the GLA.
5. Remove the screws (1) 4x and remove the GLA (2).

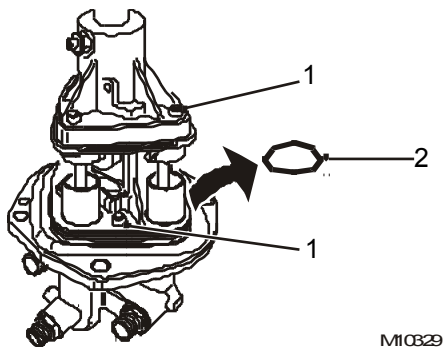

6. Remove 8x Allen screws (1).
7. Split the GLA and remove the O-ring (2) of the reservoir.

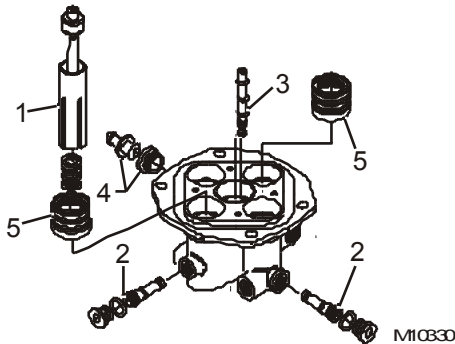

8. Remove 4x piston (1).



**Mark which piston belongs in which cylinder. Only in the two cylinders with the shortest pistons there are springs.**

9. Remove the sealing plugs and gaskets and remove 2x DPR valve (2) with help of the DPR valve tool.
10. Remove level tube (3).
11. Pull out the reservoir tube (4) and remove the rubber seal.
12. Remove the piston seal cases (5) with help of the extraction tool.



**Mark in which order and in which position the seals, O-rings en nylon seal bushes of the seal cases have been mounted.**

13. Clean the pistons and the inside of the cylinders. Ensure that all contamination inside the cylinders is removed.

## Installation

1. Install new piston seal cases (5) by pushing gently on top of the seal cases.



**It is very important to place each seal or seal case in the correct position. Note the difference between 24 mm and 26 mm pistons.**

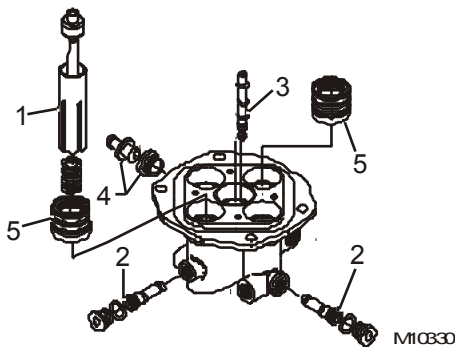
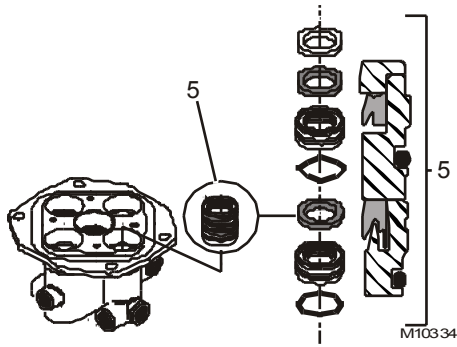

2. Install 2x DPR valve (2) with help of the DPR valve tool (tightening torque 10 Nm). Install the sealing plugs with new gaskets (tightening torque 45 Nm).
3. Install level tube (3) with a new O-ring.
4. Grease the pistons with silicone grease.
5. Insert the springs 2x in the correct cylinders and install 4x piston (1).



**There are only springs in the two cylinders with the shortest pistons.**

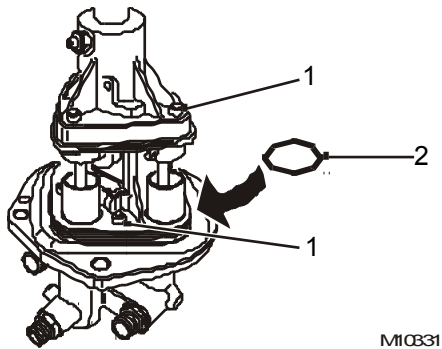

6. Grease the new rubber seal with silicone grease and press the seal in its place. Press the reservoir tube (4) in its place.
7. Grease a new O-ring (2) with silicone grease and install that O-ring.
8. Assemble the GLA and install 8x Allen screws (1) (tightening torque 8 Nm).

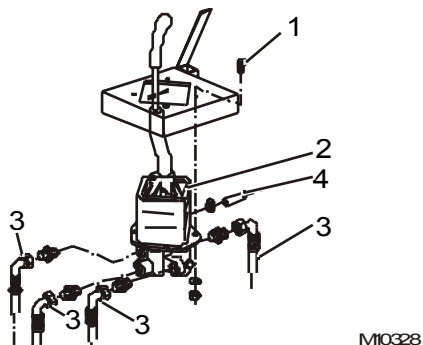

9. Position the GLA (2) and install the screws (1) 4x (tightening torque 43 Nm).
10. Install the reservoir hose (4) to the GLA with a hose clamp.
11. Install the hoses (3) to the GLA (tightening torque 45 Nm).
12. Install the gear shift rod cover to the GLA.
13. Fill and bleed the system.

### 5.1.3 Gear box actuator (GBA)

#### Removal of select cylinder

1. Drain the system.



**When you replace the select cylinder you only have to drain and, later on, fill/bleed the select circuit.**

2. Remove the hoses (1) and remove bolted joints (2).
3. Remove the GBA carefully to the side.



**Avoid splashing fluid from the bores**

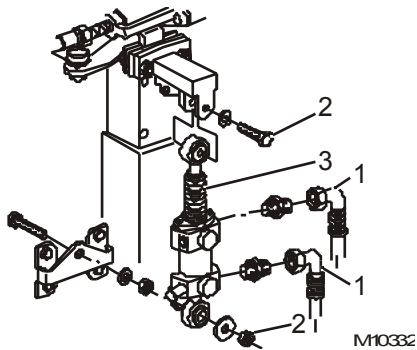

#### Removal of shift cylinder

1. Drain the system.



**When you replace the shift cylinder you only have to drain and, later on, fill/bleed the shift circuit.**

2. Remove the hoses (1) and remove bolted joints (2).
3. Remove the GBA carefully to the side.



**Avoid splashing fluid from the bores**

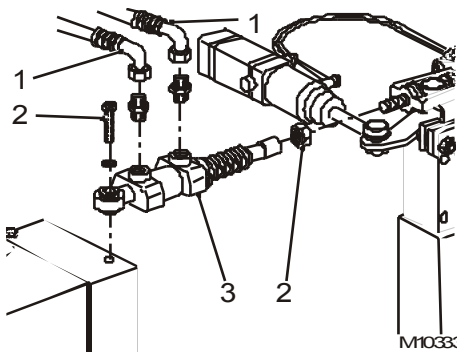

#### Installing of shift cylinder

1. Position the shift cylinder.
2. Install bolted joints (2) and install the hoses (1) (tightening torque 45 Nm).

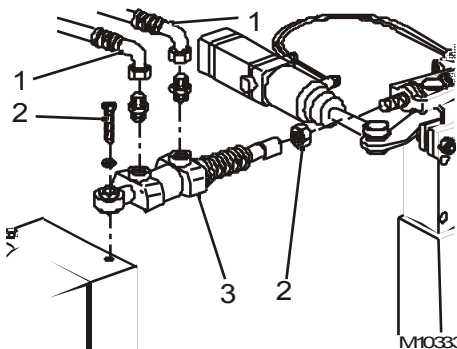



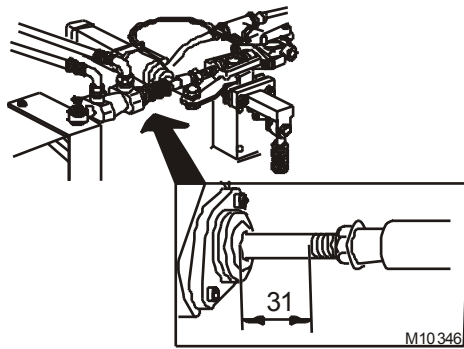

## Adjustment of the shift cylinder

1. Position the gearbox in the neutral position by moving the gearbox shift shaft, by hand, in the shift direction.
2. Adjust the shift cylinder to 31 mm (this is applicable for 6S 1600 as well as 8S 180 gearboxes).
3. Fill and bleed the shift circuit.

## Installing of select cylinder

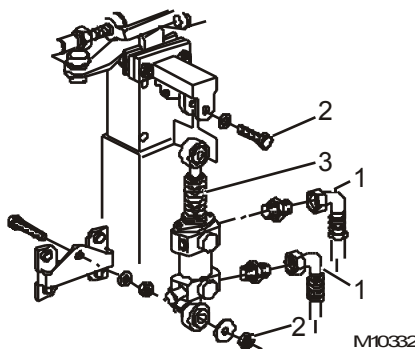

1. Position the select cylinder.
2. Install bolted joints (2) and install the hoses (1) (tightening torque 45 Nm).
3. Fill and bleed the select circuit.

## Adjustment of the select cylinder

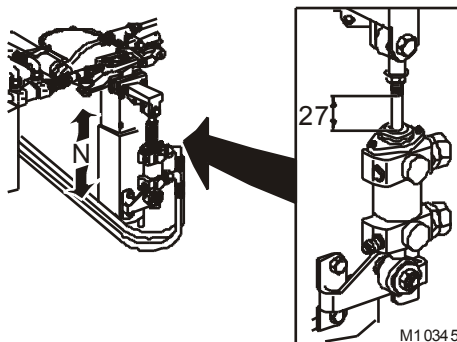

1. Position the gearbox in the neutral position by moving the gearbox shift shaft, by hand, in the select direction.



**In case of a 8S 180 gearbox you have to move the shift shaft over a noticeable locking to the outside.**

2. Adjust the select cylinder to 27 mm (in case of a 8S 180 gearbox 31 mm).
3. Fill and bleed the select circuit.

## 5.2 Maintenance

To maintain the HGS system means that you have to check the following items at every regular service:

- Check for leaks or damage to piping.
- Check for security of the GBA's to the gearbox.
- Check GLA and GBA's for correct operation and leaks.
- Check the HGS fluid level in the reservoir when the engine is cold and at a normal outside temperature (around 20°C).
- Replace the HGS fluid every three years



**Never use used oil cans to fill up the system and never fill up the system with used brake fluid.**

# 6. Filling/bleeding the system

## 6.1 Special tools

In order to fill or bleed the system the following tools are necessary:

- Brake-O-Matic Romess S15 fill equipment (Filling capacity 30 l/h at a pressure of 3-4 bar).



A fluid tank where you can set 3-4 bar air pressure on the fluid surface to force the fluid into the system can be used as well.

- Support (only if ZF 8S-180) B270537
- Quick-connector (B267736) DAF order number 1240116
- Vacuum sucker
- Reservoir cap B270538
- Brake fluid overflow tank with clear plastic hose

## 6.2 Filling the system

### 6.2.1 General

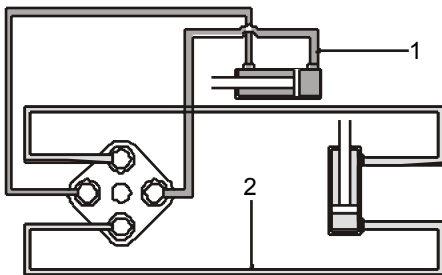

M 103 17

The HGS system is a hydraulic system which consists of 2 circuits. Each circuit can be filled separate, but it is also possible to fill both circuits at the same time. The system has to be filled with brake fluid DOT 4.



Never use mineral oil or grease to lubricate the seals and rubber parts. These are made from EPDM rubber, and even microscopic particles of mineral oil or grease can cause swelling of these rubber, and with that the breakdown of the system.

It is of the utmost importance to act in the same order as prescribed in this description when filling and bleeding the system to achieve a correct functioning HGS system.



Always wear gloves to protect skin against oil and other fluid.  
Never use fingers to check the fluid level in the reservoir.



Never use used oil cans to fill up the system and never fill up the system with used brake fluid.



Check whether there are protection caps on the bleed nipples. If not, replace the bleed nipples to prevent contaminating the system.

## 6.2.2 Draining the system



It is recommended to drain the system before filling by using a vacuum sucker on the bleed nipples.

### Draining the select circuit

1. Open the reservoir of the GLA.

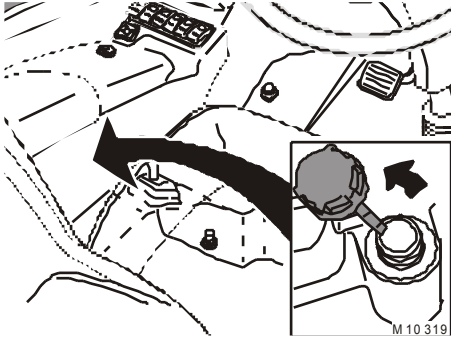

2. Connect a vacuum sucker to the bleed nipple on the select GBA.
3. Open the bleed nipple and the bleed plug 1 turn and start the vacuum sucker.

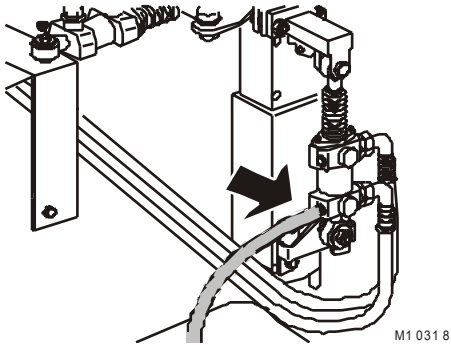

4. First move the gear lever to the far left position for a couple of minutes until you see that there is no fluid left in the system.
5. Move the gear lever to the far right position for a couple of minutes until you see that there is no fluid left in the system.
6. Stop the vacuum sucker.
7. Close the bleed nipple and bleed plug (tightening torque 8 Nm) and install the protection cap on the bleed nipple. The select circuit will then be drained.

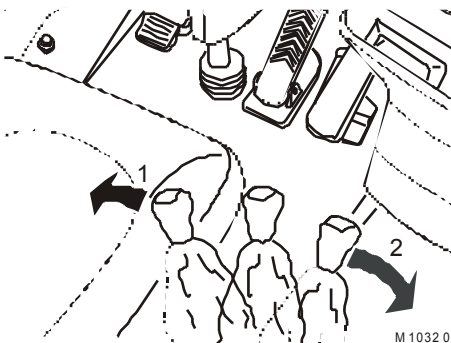

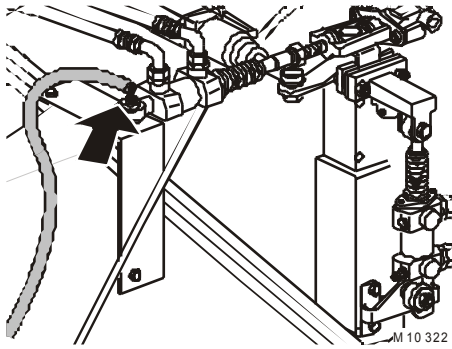

## Draining the shift circuit

1. Connect a vacuum sucker to the bleed nipple on the shift GBA.
2. Open the bleed nipple and the bleed plug 1 turn and start the vacuum sucker.

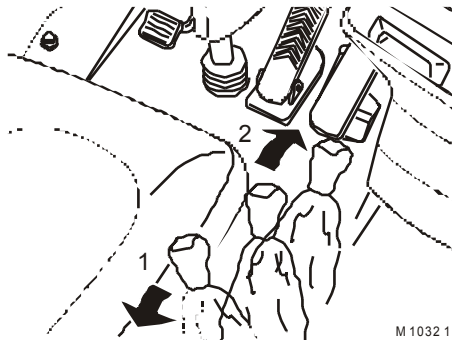

3. First move the gear lever to the far rear position for a couple of minutes until you see that there is no fluid left in the system.
4. Move the gear lever to the far front position for a couple of minutes until you see that there is no fluid left in the system.
5. Stop the vacuum sucker.
6. Close the bleed nipple and bleed plug (tightening torque 8 Nm) and install the protection cap on the bleed nipple. The shift circuit will then be drained.

### 6.2.3 Filling/bleeding the system



It is recommended to drain the system before filling by using a vacuum sucker on the bleed nipples, see: Draining the system.



It is very important to prevent air getting in the system during filling/bleeding by loose or leaking connections of the filling equipment.



Raising the vehicle at the front for about 60 cm will speed up the bleeding.

#### Filling/bleeding the select circuit

1. Open the reservoir of the GLA.
2. Install the reservoir cap B270538.

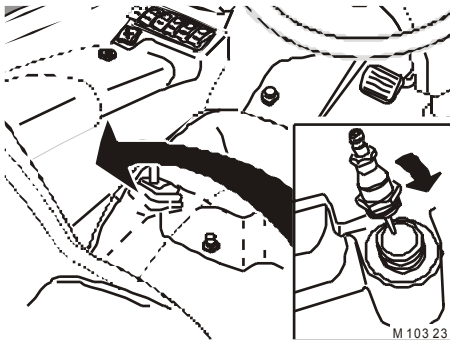

Never fill the system by pressurizing the reservoir with fluid because this will cause malfunction of the DPR valves.

3. Connect the brake fluid overflow tank with a clear plastic hose to the reservoir cap.

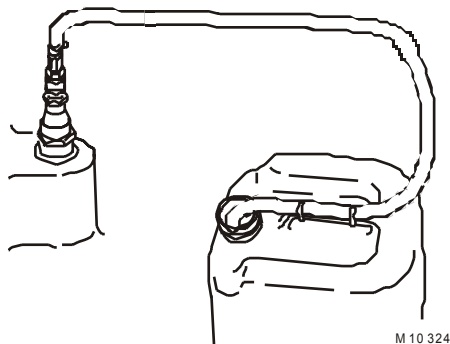

4. Connect, with help of the quick-connector (part number B267736), the filling equipment to the bleed nipple on the select GBA.

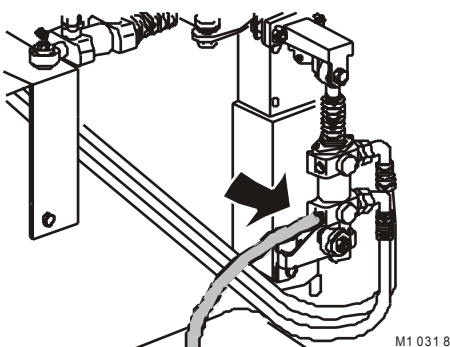

Check whether there is a protection cap on the bleed nipple. If not, replace the bleed nipple to prevent contaminating the system.



Take care there is enough DOT 4 brake fluid in the filling equipment (approximately 15 litres) in order to complete the procedure successful.

5. Open the bleed nipple and the bleed plug 1 turn and start the filling equipment.

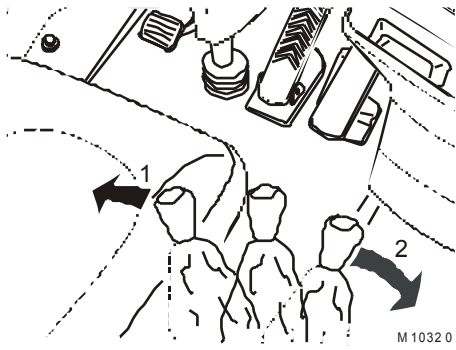

6. Move the gear lever to the far left position and wait until you don't see air bubbles any more in the plastic hose from the reservoir to the brake fluid overflow tank.
7. Shake the gear lever several times in the left position until the remaining air bubbles are gone.
8. Move the gear lever to the far right position and wait until you don't see air bubbles any more in the plastic hose from the reservoir to the brake fluid overflow tank.
9. Shake the gear lever several times in the right position until the remaining air bubbles are gone.
10. Move the gear lever slowly to the middle position.
11. Close the bleed nipple and bleed plug (tightening torque 8 Nm).
12. Stop and disconnect the filling equipment and install the protection cap on the bleed nipple. The select circuit is now filled and bled.

### Filling/bleeding the shift circuit

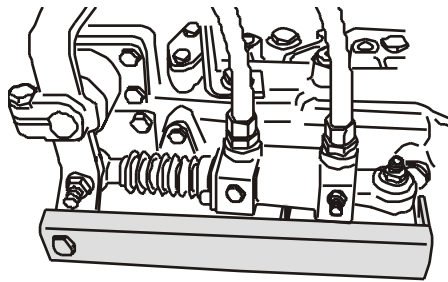

1. When bleeding the shift circuit on a 8 S-180 gearbox you first have to install a bracket (part number 270537) in order to avoid the GBA switching in a gear during bleeding the shift circuit.

M 10 325

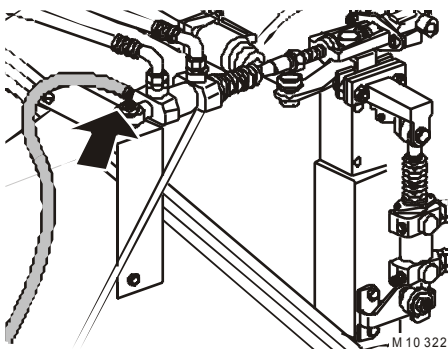

2. Connect the filling equipment, with help of the quick-connector (part number B267736), to the bleed nipple of the shift GBA.



**Check whether there is a protection cap on the bleed nipple.  
If not, replace the bleed nipple to prevent contaminating the system.**



**Take care there is enough DOT 4 brake fluid in the filling equipment (approximately 15 litres) in order to complete the procedure successful**

3. Open the bleed nipple and the bleed plug 1 turn and start the filling equipment.

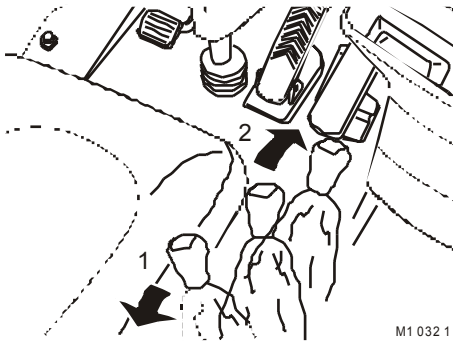

4. Move the gear lever to the far rear position and wait until you don't see air bubbles any more in the plastic hose from the reservoir to the brake fluid overflow tank.
5. Shake the gear lever several times in the rear position until the remaining air bubbles are gone.
6. Move the gear lever to the far front position and wait until you don't see air bubbles any more in the plastic hose from the reservoir to the brake fluid overflow tank.
7. Shake the gear lever several times in the front position until the remaining air bubbles are gone.
8. Move the gear lever slowly to the middle position.
9. Close the bleed nipple and bleed plug (tightening torque 8 Nm), and if a 8 S-180 gearbox: remove the bracket.
10. Stop and disconnect the filling equipment and install the protection cap on the bleed nipple. The shift circuit is now filled and bled.

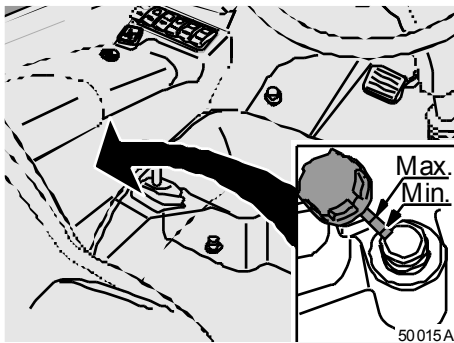

11. Remove the filler cap of the reservoir.

 **Take care that there is no fluid spilled on the interior of the coach.**

12. Check the fluid level in the HGS reservoir and suck out or fill up if necessary.

### Self adjustment

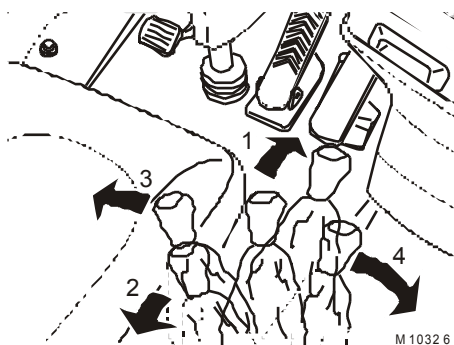

13. Move the gear lever slowly forwards, backwards and then left and right, and repeat this movement several times until the gear lever position is adjusted.

 **If the system doesn't feel completely stable there may be a small amount of air in the system which normally will be forced out after driving for a while.**

 **If it is not possible to change gear or you can move the gear lever to the end stop at normal shifting a fault occurred in the filling procedure. If the problem is only in the shift direction, it is not necessary to fill the select circuit, and vice versa.**

14. Check the fluid level in the HGS reservoir and fill up if necessary when the system is functioning correctly.